

Assembly Instructions

Sun Room & Sun Lounge - Clear Glazing

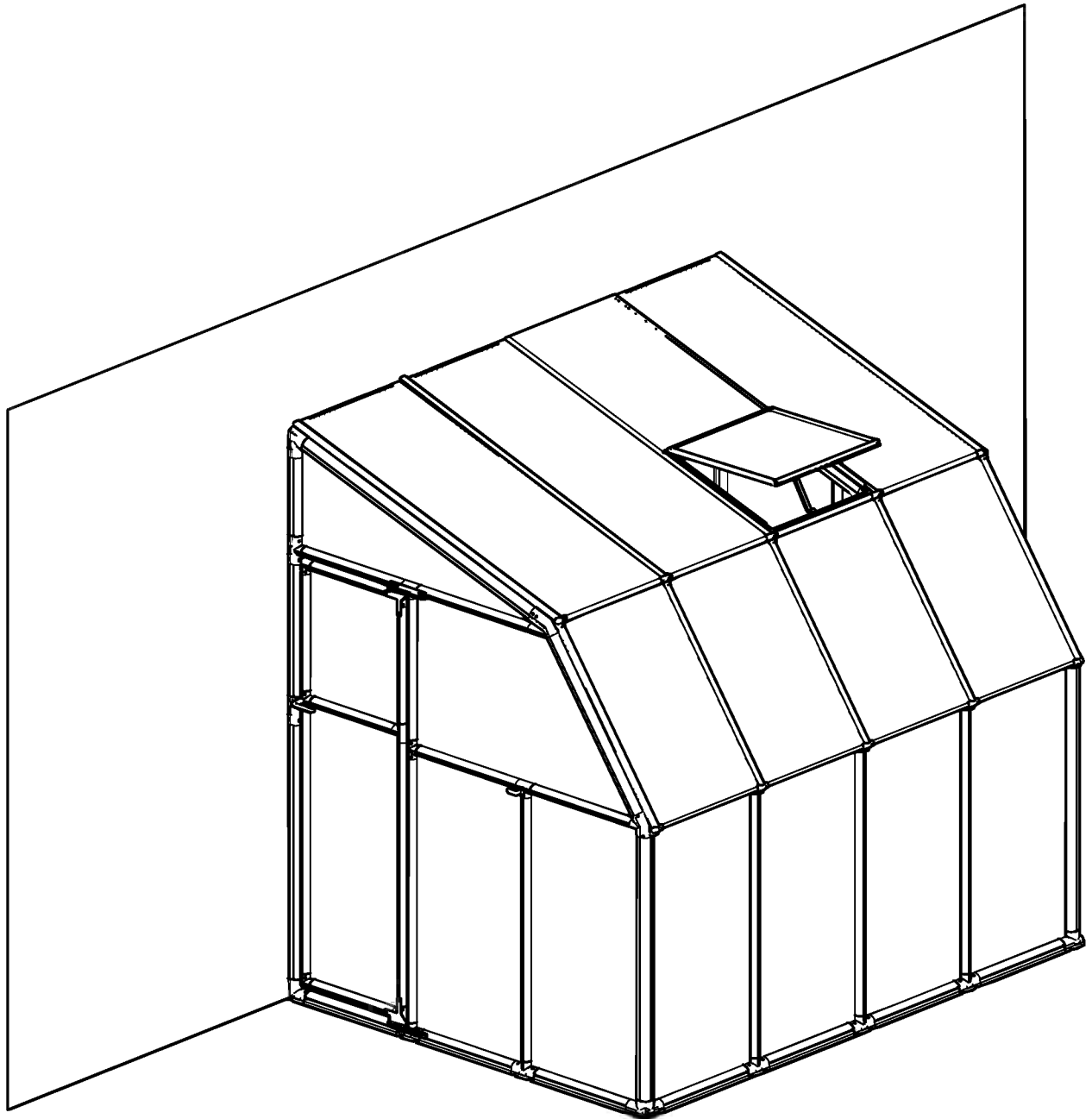

After Sale Service

Email: customer.service@palram.com

USA 877-627-8476
Canada 1 800-866-5749

England 01302-380775
Germany 0180-522-8778

France 0169-791-094
International +972 4-848-6942

IMPORTANT

Please read these instructions carefully before you start to assemble this greenhouse.
Keep these instructions in a safe place for future reference.

GENERAL

- Rion is not responsible for the misuse of tools or parts
- All opaque panels with the stamped words THIS SIDE OUT indicates the outside to create full UV protection. Remove plastic sticker as panels are locked in place
- All clear panels are protected by plastic film on both sides and don't have specific direction to install. Remove the plastic before installation
- The quantity of parts that required for extension is depending on purchased packages number
- This manual is suitable San Room (clear) and Sun Lounge (clear + opaque)
- Door assembly can be made from left or right

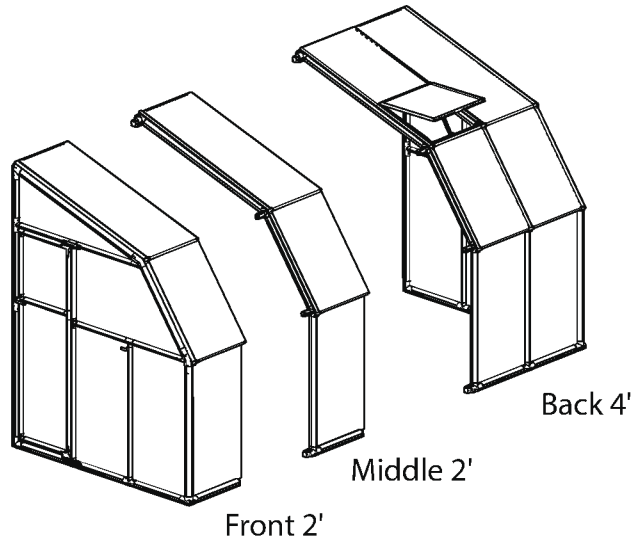

Greenhouse Sizes	Pack Qty (Front 2')	Pack Qty (Middle 2')	Pack Qty (Back 4')
6' x 8'	1	1	1
6' x 10'	1	2	1
6' x 12'	1	3	1

SAFETY ADVICE

- Rion is not responsible for the misuse of tools or parts.
- It is of utmost importance to assemble all of the parts according to the directions. Please follow them closely and do not skip any step.
- We strongly recommend using work gloves during assembly.
- If using a step ladder or power tools ensure that you follow the manufacturer's safety advice.
- If local building codes require permits or licenses make sure that they are acquired before beginning.
- Your Greenhouse should be secure by anchored to the prepared foundation using the recommended hardware.
- Do not attempt to assemble the greenhouse in windy or wet conditions.
- Dispose of all plastic bags safely keep them out of reach of small children.
- Keep children away from the assembly area.
- Do not lean against or push the greenhouse during construction.
- Do not attempt to assemble this greenhouse if you are tired, have taken drugs or alcohol or if you are prone to dizzy spell.
- When your Greenhouse is fully assembled examine it for sharp edges and trim with a razor knife if necessary.
- If you live in a hot climate, where outside temperatures exceed 46° C (115° F) in the sun or 36° C (99° F) in the shade, this may cause the temperature inside the greenhouse to exceed 55° C (131° F). Such conditions may harm your plants and will damage the greenhouse by warping structural profiles. In order to prevent damage:
 - Ensure good ventilation during hot days.
 - Make sure that the temperature inside the green house never exceeds 55° C (131° F) by providing a shading screen, such as the Shade Net (available as an accessories option).

Note: RION is not responsible for any damage due to high temperatures.

* Always close roof vent in high winds.

REQUIRED TOOLS

- GT1 - Special tool to connect pins through lined up holes. Pin Tool fix and lock profiles in place



- To assemble this product you will need the following tools (these items are not supplied)

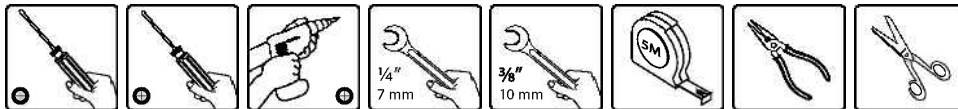

BEFORE ASSEMBLY

- Rion is not responsible for the misuse of tools or parts.
- Selecting a site - the greenhouse must be, positioned and fixed on a flat level surface.
- Sort the parts and check according to the contents parts list. Do not begin assembly if any parts are missing.
- If you prepare a concrete foundation do not excavate and pour concrete in frozen ground.
- We recommend that you place your Greenhouse in a spot where it will receive direct sunlight and will be protected from the wind as much as possible. The door should not face prevailing winds.

DURING ASSEMBLY

Step 1: place door hinge according to the desired direction of the door opening.

Steps 1-4: Arrange all 2D connectors with the stamped word OUT facing the outside of the greenhouse.

Step 5:

- Make sure that the frame is perfectly straightened by measuring the diagonals and verifying that they are the same.
- Make sure that the frame is level and anchor it with screw/screw + dibble/spike (not supplied) according to the selected surface.
- The wall to which you are securing your Sun Lounge must be 90° to the foundation

Steps 9, 10: Walls assembly must be made gradually (1.panel 2.rofile 3.connector) according to describe method in **step #8**

Step 18: Arrange all 2D connectors with the stamped word OUT facing the outside of the greenhouse.

Step 27: Make sure that the top frame is leveled with wall. Fix it using one of the two options illustrated with a screw/bolt + plugs (not supplied) according to the selected wall.

Steps 44, 49: Insert the rubber strip from the outside the greenhouse. Cut the remaining edges as needed.

*Relevant only for sun room/lounge with clear panels.

Attention:



When encountering the information icon, please refer to the relevant assembly step for additional comments and assistance.



This icon indicates that the installer should be inside the product.

IMPORTANT

Veillez lire attentivement ces instructions avant de commencer le montage de cette serre. Conservez ces instructions en lieu sûr pour référence ultérieure.

GÉNÉRAL

- Rion n'assume aucune responsabilité en cas de mauvaise utilisation des outils ou des pièces
- Tous les panneaux opaques tamponnés avec les mots THIS SIDE OUT indiquent l'extérieur pour créer une protection complète contre les UV. Retirez l'étiquette en plastique une fois que les panneaux sont fixés
- Tous les panneaux transparents sont protégés par des films en plastique des deux côtés et n'ont pas de sens d'installation particulière. Enlevez le plastique avant l'installation
- La quantité de pièces nécessaires pour une extension dépend du nombre de paquets achetés
- Ce manuel est adapté pour San Room (transparent) et Sun Lounge (transparent + opaque)
- L'assemblage de la porte peut se faire par la gauche ou par la droite

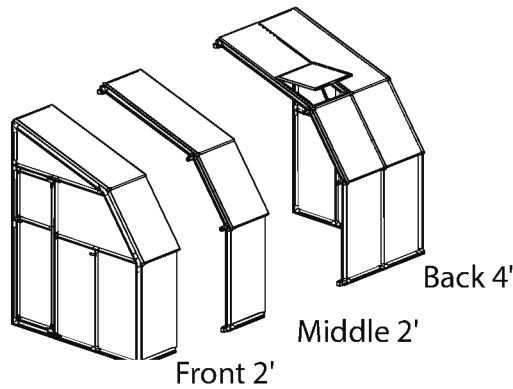

Greenhouse Sizes	Pack Qty (Front 2')	Pack Qty (Middle 2')	Pack Qty (Back 4')
6' x 8'	1	1	1
6' x 10'	1	2	1
6' x 12'	1	3	1

CONSEILS DE SÉCURITÉ

- Rion n'est pas responsable de la mauvaise utilisation des outils ou des pièces.
- Il est crucial d'assembler les pièces conformément aux instructions. Veuillez les suivre attentivement et ne sautez aucune étape.
- Nous recommandons vivement l'utilisation de gants de travail pendant le montage.
- Si vous utilisez un escabeau ou des outils électriques, assurez-vous de suivre les conseils de sécurité du fabricant.
- Si les réglementations de construction locales exigent un permis ou une licence, assurez-vous de les avoir avant de commencer.
- Votre serre doit être sécurisée en étant attachée à la fondation préparée et en utilisant le matériel recommandé
- N'essayez pas d'assembler la serre dans des conditions venteuses ou humides.
- Jetez tous les sacs plastique ou conservez-les hors de portée des jeunes enfants.
- Maintenez les enfants à distance de la zone de montage.
- Ne vous appuyez pas sur la serre et ne la poussez pas pendant la construction.
- N'essayez pas d'assembler la serre si vous êtes fatigué, avez consommé de la drogue ou de l'alcool, ou si vous êtes sujet aux étourdissements.
- Les objets chauds tels que les grills récemment utilisés, les chalumeaux, etc. ne doivent pas être conservés dans la serre. Assurez-vous qu'il n'y a aucun tuyau ou câble caché dans le sol avant d'insérer les piquets.
- Une fois votre serre complètement assemblée, examinez-la à la recherche de bords tranchants et ébarbez avec un rasoir droit le cas échéant.
- Si vous vivez dans un climat chaud, où les températures extérieures dépassent les 46°C (115°F) au soleil ou 36°C (99°F) à l'ombre, la température à l'intérieur de la serre pourrait dépasser les 55°C (131°F). De telles conditions pourraient abîmer vos plantes et endommageront la serre en déformant la structure. Afin d'empêcher tout dommage:
 - Assurez une bonne ventilation les jours chauds.
 - Assurez-vous que la température à l'intérieur de la serre ne dépasse jamais 55 °C (131 °F) en lui fournissant un écran contre le soleil, tel qu'un filet pare-soleil (disponible en tant qu'accessoire).

Remarque: RION ne saurait être tenu pour responsable de tout dommage dû à des températures élevées.

* Toujours fermer les événements du toit par vent fort.

OUTILS NÉCESSAIRES

- GT1 - Special tool to connect pins through lined up holes. Pin Tool fix and lock profiles in place
- Pour assembler ce produit, vous aurez besoin des outils suivants (non fournis)

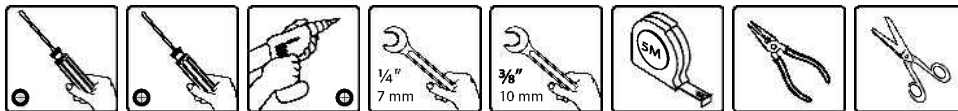

AVANT L'ASSEMBLAGE

- Rion n'est pas responsable de la mauvaise utilisation des outils ou des pièces.
- Choisissez un site – la serre doit être placée et fixée à une surface plate.
- Triez les pièces et vérifiez par rapport à la liste. Ne commencez pas à assembler si une quelconque pièce est manquante.
- Si vous préparez une fondation en béton, ne creusez pas et ne mettez pas de béton dans un sol gelé.
- Nous vous recommandons de placer la serre dans un lieu où elle recevra directement la lumière du soleil et où elle sera protégée du vent autant que possible. Ne pas placer la porte face aux vents dominants.

PENDANT L'ASSEMBLAGE

Étapes 1: Disposez tous les connecteurs 2D avec le mot OUT vers l'extérieur de la serre.

Étapes 1-4: Arrange all 2D connectors with the stamped word OUT facing the outside of the greenhouse.

Étapes 5:

- Assurez-vous que le cadre est parfaitement droit en mesurant les diagonales et en vérifiant qu'elles sont identiques.
- Assurez-vous que le cadre est à l'horizontale et fixez-le à l'aide de vis / vis + plantoirs / pointes (non fournis) en fonction de la surface choisie.
- Le mur auquel vous attachez votre verrière doit être à 90° par rapport à la fondation.

Étapes 9, 10: Le montage des murs doit être effectué progressivement (1.panneau 2.profil 3.connecteur) selon la méthode décrite en étape # 8

Étapes 18: Disposez tous les connecteurs 2D avec le mot OUT vers l'extérieur de la serre.

Étapes 27: Assurez-vous que le cadre supérieur est aligné avec le mur. Fixez-le à l'aide de l'une des deux options illustrées, avec une vis / boulon + bouchons (non fournis) en fonction du mur choisi.

Étapes 44, 49: Insérez la bande en caoutchouc depuis l'extérieur de la Serre. Coupez les bords restants, si nécessaire. *Valable uniquement pour les verrières avec des panneaux clairs.

Attention:



Lorsque vous voyez l'icône Information, veuillez vous référer à l'étape d'assemblage correspondante pour des commentaires et une assistance complémentaires.



Cette icône indique que l'installateur devrait se trouver à l'intérieur du produit.

WICHTIG!

Lesen Sie diese Aufbauanleitung sorgfältig durch, bevor Sie mit dem Zusammenbau beginnen.
Bewahren Sie die Anleitung auf.

INFORMATIONEN

- RION ist nicht verantwortlich für eine fehlerhafte Benutzung von Werkzeugen oder Bauteilen.
- Die DoppelstegScheiben sind auf der UV-beständigen Seite mit einem Aufkleber "THIS SIDE OUT" versehen. Diese Seite muss zwingend nach Außen! Entfernen Sie den Aufkleber während des Einbaus der Scheibe.
- Die Acryl-Scheiben sind beidseitig mit einem Plastikfilm überzogen. Beide Seiten sind UV-Beständig. Entfernen Sie den Aufkleber während des Einbaus der Scheibe.
- Die Aufbauanleitung gilt für das RION Sun Room & Sun Lounge.
- Die Tür kann auf der rechten oder linken Hausseite montiert werden.

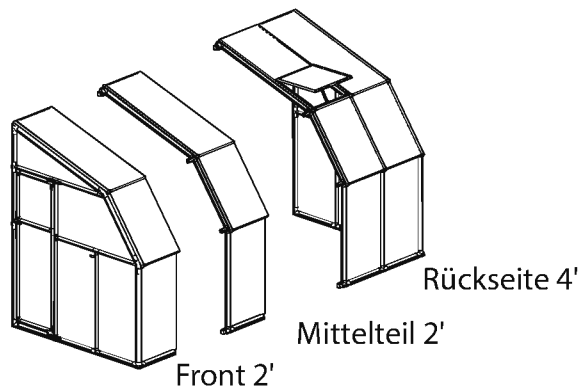

Gewächshaus Größen	Verp. Einh. (Front 2')	Verp. Einh. (Mittelteil 2')	Verp. Einh. (Rückseite 4')
Sun Room 34	1	1	1
Sun Room 35	1	2	1
Sun Room 36	1	3	1

SICHERHEITSHINWEISE

- RION ist nicht verantwortlich für eine fehlerhafte Benutzung von Werkzeugen oder Bauteilen.
- Das Gewächshaus muss zwingend anhand der Aufbauanleitung Schritt für Schritt aufgebaut werden. Bitte lassen Sie keinen Schritt aus.
- Es ist ratsam während dem Aufbau Handschuhe zu tragen.
- Sofern Sie eine Leiter oder elektrisches Werkzeug benutzen, folgen Sie den Anweisungen des jeweiligen Herstellers.
- Erkundigen Sie sich bitte vor dem Aufbau nach eventuellen Bauvorschriften beim zuständigen Amt.
- Das Gewächshaus muss fest am Boden verankert (Beton, Holz etc.) oder mit Hilfe des empfohlenen Werkzeuges an der mitgelieferten Basis befestigt werden.
- Der Aufbau sollte nicht bei starkem Wind oder Regen erfolgen.
- Halten Sie alle Plastiktüten & Verpackungsmaterialien von Kindern fern.
- Halten Sie Kinder vom Aufbauplatz fern.
- Während des Aufbaus nicht gegen die Konstruktion lehnen.
- Sobald Sie das Gewächshaus komplett aufgebaut haben, entfernen Sie (sofern nötig) scharfe Kanten mit einem Messer oder Cutter.
- Wenn Sie in einem Land leben, in dem die Außentemperaturen in der Sonne 46° C und im Schatten 36° C betragen, können die Temperaturen im Gewächshaus 55° C überschreiten. Solche Temperaturen können Ihre Pflanzen schädigen und zum Verbiegen der Profile führen. Durch die folgenden Maßnahmen können Sie solche Schäden verhindern:
 - Achten Sie an warmen Tagen auf eine gute Belüftung.
 - Achten Sie darauf, dass die Temperatur im Gewächshaus 55° C nicht überschreitet. Sorgen Sie für einen ausreichenden Sonnenschutz, zum Beispiel mit Hilfe des RION Schattennetzes (optional erhältlich).

HILFSMITTEL

- GT1 - spezielles RION Aufbauwerkzeug zur Befestigung der Pins in den Profilen.
- Folgende Hilfsmittel werden für den Aufbau benötigt.

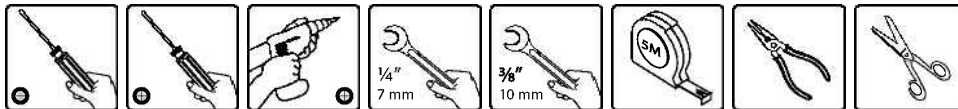

VOR DEM AUFBAU

- RION ist nicht verantwortlich für eine fehlerhafte Benutzung von Werkzeugen oder Bauteilen.
- Das Gewächshaus muss auf einer ebenen Fläche aufgebaut werden.
- Kontrollieren Sie vorab anhand der der Stücklisten die Vollständigkeit der Teile.
- Wenn Sie ein Betonfundament vorbereiten, sollten Sie dies nicht bei gefrorenem Boden tun.
- Wir empfehlen Ihnen Ihr Gewächshaus so zu platzieren, dass es der direkten Sonneneinstrahlung ausgesetzt und so weit wie möglich vor Winden geschützt ist. Richten Sie die Türen und Fenster so aus, dass diese nicht gegen den Wind stehen.

AUFBAUHINWEISE

Schritt 1: place door hinge according to the desired direction of the door opening.

Schritt 1-4: Platzieren Sie alle 2D-Verbinder mit dem gestempelten Wort "OUT" nach Außen!

Schritt 5:

- Stellen Sie sicher, dass sich das Haus im Winkel befindet, indem Sie die Diagonalen messen. X=Y
- Sofern Sie nicht das RION Fundament bestellt haben: Stellen Sie sicher das das Haus in der Waage steht. Befestigen Sie den Bodenrahmen mit Dübeln, Schrauben, Erdankern(nicht im Lieferumfang enthalten) an Ihrem bestehenden Fundament.

Schritt 9, 10: Der Aufbau der Seitenwände muss in den nachstehenden Schritten erfolgen: (1. Doppelstegplatte, 2. Profile, 3. Pins), siehe **Schritt 8**.

Schritt 18: Platzieren Sie alle 2D-Verbinder mit dem gestempelten Wort "OUT" nach Außen!

Schritt 27: Befestigen Sie den Wandanschluss mit Dübeln, Schrauben(nicht im Lieferumfang enthalten) an Ihrer Wand.

Schritt 44, 49: Befestigen Sie den mitgelieferten Gummi von Außen an den Scheiben. Schneiden Sie sich diesen nach Bedarf zurecht.

*Nur nötig bei Modellen mit Acryl-Scheiben.

ACHTUNG:



Dieses Symbol verweist auf zusätzliche Information des jeweiligen Aufbauschnittes unter AUFBAUHINWEISE.



Bei diesem Aufbauschnitt sollte sich der Monteur innerhalb des Hauses befinden.

ES

IMPORTANTE

Por favor, lea estas instrucciones cuidadosamente antes de comenzar a montar este invernadero. Guarde estas instrucciones en un lugar seguro para consultarlo en el futuro.

GENERAL

- Rion no es responsable de la mala utilización de herramientas o piezas.
- Usted puede adquirir un Paquete mediano de Hobby Gardener para ampliar el tamaño de su invernadero y satisfacer sus necesidades.
- Los dibujos de este manual están diseñados para un invernadero de 6' x 6' (1,8 x 1,8 metros) que consiste en una unidad frontal y una unidad posterior. Por favor, tenga en cuenta que la cantidad de piezas necesarias para un invernadero de mayor tamaño se enumera en los pasos de abajo, dependiendo de la cantidad de paquetes medianos que haya adquirido.
- Todos los paneles con las palabras impresas ESTE LADO FUERA (THIS SIDE OUT) deben mirar hacia fuera para crear una protección total contra rayos UV. Retire la pegatina de plástico según va fijando los paneles en su lugar.
- Si ha adquirido la Base de resina de invernadero Rion siga las instrucciones de montaje en el envase. La Base modular de invernadero se puede colocar en un agujero excavado o en el suelo. En cualquier caso, usted necesitará suficiente grava, tierra u otro material adecuado para rellenar la base (vea la tabla de abajo). Se incluyen todas las herramientas necesarias..

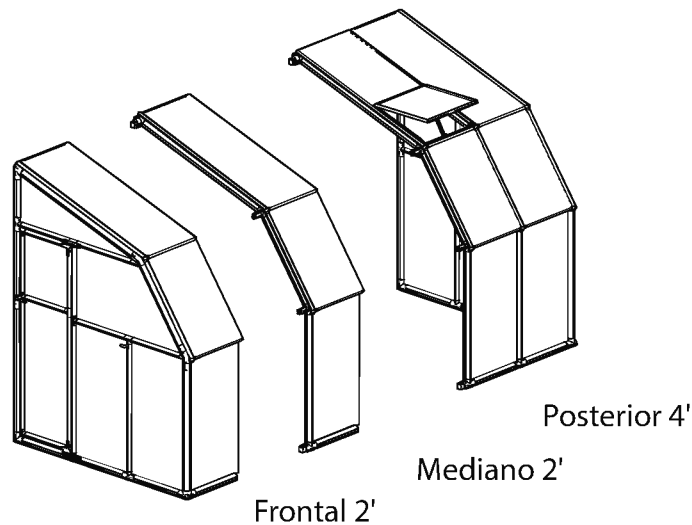

Tamaños de invernadero	Cdad. del paquete (Frontal 2')	Cdad. del paquete (Mediano 2')	Cdad. del paquete (Posterior 4')
6' x 8'	1	1	1
6' x 10'	1	2	1
6' x 12'	1	3	1

AVISO DE SEGURIDAD

- Rion no es responsable de la mala utilización de herramientas o piezas.
- Es de suma importancia montar todas las piezas siguiendo las instrucciones. Por favor, sígalas atentamente y no omita ningún paso.
- Recomendamos encarecidamente utilizar guantes de trabajo durante el montaje.
- Si utiliza una escalera o herramientas eléctricas, asegúrese de seguir los consejos de seguridad del fabricante.
- Si las normas de construcción locales requieren permisos o licencias, asegúrese de adquirirlos antes de comenzar.
- Su invernadero debería fijarse anclándolo a la base preparada usando las herramientas recomendadas.
- No intente montar el invernadero bajo condiciones de viento o de lluvia.
- Tire todas las bolsas de plástico y manténgalas fuera del alcance de los niños
- Mantenga a los niños fuera del área de montaje.
- No se apoye o empuje el invernadero durante su construcción.
- No intente montar este invernadero si está cansado, ha tomado drogas o alcohol o si es propenso a mareos.
- Los objetos calientes como parrillas usadas recientemente, sopletes, etc., no deben guardarse en el invernadero. Asegúrese de que no hay cables o tubos ocultos en el suelo antes de insertar las clavijas.
- Cuando su invernadero esté montado por completo, examínelo buscando filos cortantes y recórtelos con una navaja si es necesario.
- Si vive en un clima cálido donde las temperaturas exteriores exceden los 46° C (115° F) al sol o los 36° C (99° F) a la sombra, esto podría hacer que la temperatura en el interior del invernadero supere los 55° C (131° F). Dichas condiciones podrían dañar sus plantas y su invernadero deformando los perfiles estructurales. Para evitar daños:
 - Asegúrese de que hay una buena ventilación durante días calurosos.
 - Asegúrese de que la temperatura en el interior del invernadero no supere nunca los 55° C (131° F) proporcionándole una sombra como Shade Net (disponible como accesorio).

Nota: RION no es responsable por cualquier daño debido a altas temperaturas.

* Cierre siempre el respiradero del techo cuando haga mucho viento.

HERRAMIENTAS NECESARIAS

- GT1 - Herramienta especial para conectar pernos a través de los orificios alineados. Esta herramienta fija y bloquea los perfiles en su lugar.
- Para montar este producto necesitará las siguientes herramientas (no suministradas)

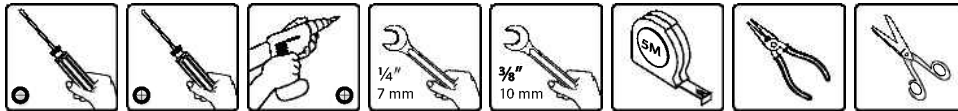

ANTES DEL MONTAJE

- Rion no es responsable de la mala utilización de herramientas o piezas.
- Seleccione un lugar. El invernadero debe estar situado y fijado en una superficie llana.
- Clasifique las piezas y compruébelas según la lista del contenido. No comience el montaje si falta alguna pieza.
- Si prepara una base de hormigón no excave y vierta hormigón sobre suelo congelado.
- Le recomendamos que coloque su invernadero en un punto donde reciba luz directa del sol y esté protegido del viento lo máximo posible. La puerta no debería estar de cara a vientos predominantes.

DURANTE EL MONTAJE

Paso 1: sitúe las bisagras de la puerta según la dirección deseada de apertura de la puerta.

Pasos 1-4: disponga todos los conectores 2D con la palabra inscrita OUT mirando al exterior del invernadero.

Paso 5:

- Asegúrese de que el marco está perfectamente derecho midiendo las diagonales y verificando que son iguales.
- Asegúrese de que el marco está nivelado y áncelo con tornillo / tornillo + plantador / punta (no suministrados) según la superficie seleccionada.
- La pared a la que fije su Sun Lounge debe tener 90° con respecto a la base.

Pasos 9, 10: el montaje de las paredes se debe hacer de forma gradual (1. panel, 2. perfil, 3. conector) de acuerdo al método descrito en el **paso n.º 8**

Paso 18: disponga todos los conectores 2D con la palabra inscrita OUT mirando al exterior del invernadero.

Paso 27: asegúrese de que el marco superior está nivelado con la pared. Fíjelo usando una de las dos opciones ilustradas con un tornillo / perno + tapones (no suministrados) según la pared seleccionada

Pasos 44, 49: inserte la tira de goma desde el exterior del invernadero. Corte los filos restantes según sea necesario.

* Solamente permitente para Sun room/Sun lounge con paneles transparentes

Atención:



cuando encuentre el icono de información, por favor, consulte el paso de montaje pertinente para obtener comentarios adicionales y asistencia.



Este icono indica que el instalador debería estar dentro del producto.

VIKTIG

Les disse instruksjonene nøye før du setter sammen drivhuset.
Plasser instruksjonene på et trygt sted for fremtidig referanse.

GENERAL

- Rion tar ikke ansvar for misbruk av verktøy eller deler.
- Alle ugjennomsiktige paneler med ordene 'THIS SIDE OUT' hentyder at skriftsiden skal vendes utover for å beskytte mot UV-strålinger.
Fjern plastklistremerkene etter panelene har blitt låst på plass.
- Alle gjennomsiktige paneler beskyttes av en plastfilm på begge sider og behøver ikke å installeres på nå spesifikt vis. Fjern plastikken før du monterer de på plass.
- Antall deler som trengs til utviding er avhengig av hvor mange pakker som ble kjøpt.
- Denne bruksanvisningen kan brukes til San Room (gjennomsiktig) og Sun Lounge (gjennomsiktig + ugjennomsiktig).
- Døren kan monteres på venstre eller høyre side.

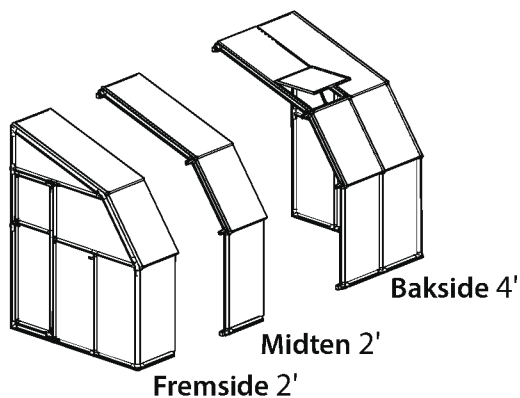

Drivhusstørreøser	Pakkeant (Fremside 2')	Pakkeant (Midten 2')	Pakkeant (Bakside 4')
6' x 8'	1	1	1
6' x 10'	1	2	1
6' x 12'	1	3	1

SIKKERHETSTIPS

- Rion skal ikke holdes ansvarlig for misbruk av verktøy eller deler.
- Det er viktig å montere alle delene i henhold til instruksjonene. Følg dem nøye og ikke hopp over steg.
- Vi anbefaler sterk å bruke arbeidshansker under montering.
- Dersom man bruker en stige eller elektriske verktøy må du forsikre deg om at du følger fabrikantens sikkerhetsinstruksjoner
- Dersom lokale byggekoder krever tillatelser eller lisenser må du passe på å få disse før du begynner.
- Ditt drivhus bør sikres med ankere til grunnmuren ved å bruke anbefalt verktøy.
- Ikke forsøk å montere drivhuset i vind eller våte forhold.
- Kast alle plastikkposene og hold dem borte fra små barn.
- Hold barna unna monteringsområdet.
- Ikke len mot eller dytt drivhuset under montering.
- Ikke forsøk å montere drivhuset dersom du er trett, har tatt narkotika eller alkohol eller om du har tendenser til å bli svimmel.
- Varme elementer som griller, flammekastere osv. må ikke lagres i drivhuset. Forsikre at det ikke er borgjemte rør eller kabler på bakken før du setter i polene.
- Når drivhuset er ferdig montert må du undersøke for skarpe kanter og trimme med en barberkniv om nødvendig.
- Dersom du bort i et varmt klima hvor utendørstemperaturer overstiger 46° C (115° F) i solen eller 36° C (99° F) i skyggen da dette kan forårsake temperaturer i drivhuset på over 55° C (131° F). Slike forhold kan skade plantene og vil skade drivhuset ved å bøye strukturprofilene. For å forhindre skade:
 - Forsikre god ventilasjon på varme dager.
 - Pass på at temperaturen inni drivhuset ikke overstiger 55° C (131° F) ved å gi det en skyggebelagt skjerm som skyggenettet (tilgjengelig som et alternativt tilbehør).

Merk: Rion er ikke ansvarlig for skade forårsaket av høye temperaturer.

*Alltid lukk takluken ved sterk vind.

PÅKREVDE VERKTØY

- GT1 - Spesialverktøy for å koble sammen poler gjennom opplinjede hull. Pin verktøy fiks og lås profilene på plass.
- For å montere produktet vil du trenge følgende verktøy (følgende enheter følger ikke med).

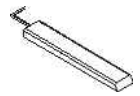
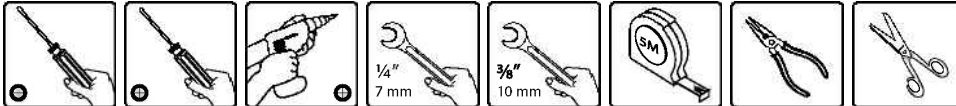

FØR MONTERING

- Rion skal ikke holder ansvarlig for misbruk av verktøy eller deler.
- Det å velge et sted - drivhuset må være posisjonert og fast på en flat overflate.
- Sorter deler og sjekk i henhold til innholdslisten for deler. Ikke begynn monteringen dersom du mangler deler.
- Dersom du forbereder en betinggrunn ikke grav og hell beting ned i frossen grunn.
- Vi anbefaler at du plasserer drivhuset hvor det vil få sollys og beskyttes fra vinden så mye som mulig. Døren må ikke være vendt mot vinden.

UNDER MONTERING

Step 1: Plasser dørhengsler i henhold til ønsket retning på døråpningen.

Steps 1-4: Organiser alle 2D tilkoblinger med samme stemplede ord UT utover som utsiden på drivhuset.

Step 5:

- Pass på at rammen er helt rett ved å måle diagonalene og verifisere at de er like.
- Vegg som du sikrer til solrommet må være 90 grader på grunnmuren.

Steps 9, 10: Montering av veggene må gjøres gradvis (1 panel, 2 rofil 3. tilkobler) i henhold for å beskrive metoden i **sted #8**.

Step 18: Organiser alle 2D tilkoblere med det stemplede ordet UT utover som utsiden på drivhuset.

Step 27: Pass på at topprammen er jevn med veggene. Fiks det ved å bruk den av de to alternativene illustrert med en skrue/bolt + plugg (medfølger ikke) i henhold til valgt vegg.

Steps 44, 49: Installer gummistripen fra utsiden på drivhuset. Kutt de gjenværende kantene ved behov.

- Relevant kun for solrom med klare paneler.

Merk:





Når du ser informasjonsikonet må du henvise til det relevante monteringssteget for tilleggskommentarer og assistanse.



Dette ikonet indikerer at installasjonen er inni produktet.



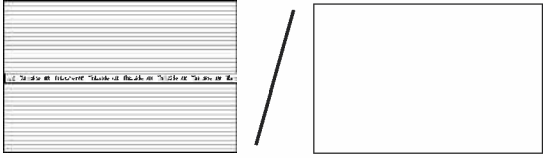
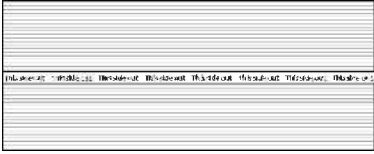
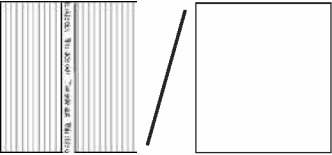
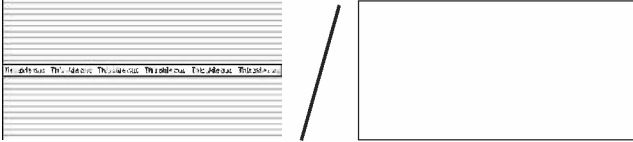
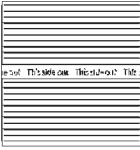
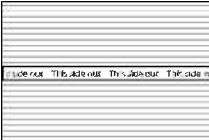
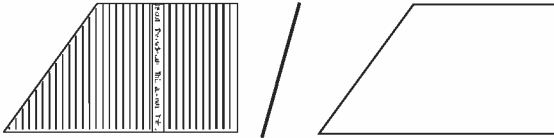
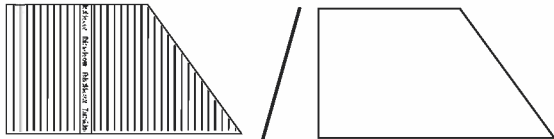







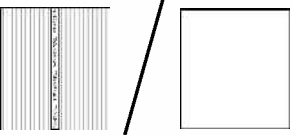
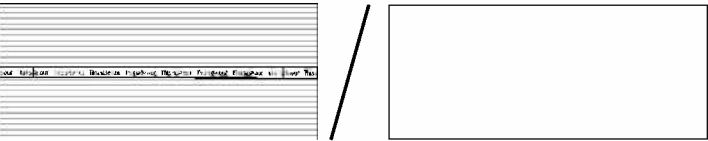



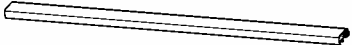



Contents



Item		Front	Back	Middle
PN55		1	2	1
PN57		1	1	1
7628 / PN53		0	1	0
7539 / PN1		3	5	1
586		0	1	0
7630		0	1	0
7619 / PN51		0	1	0
7620 / PN51		1	0	0
7617		0	1	0
7618		1	0	0



Contents



Item		Front	Back	Middle	
7616 / PN128		1			
7544 / PN127		1			
72		2			
73			2		
74			4	2	
7612			1	1	
7611			1	1	
7613				2	1
7614				2	1
7608			1	3	1
7610				2	1
7609			1	1	
7552			2	4	2
DSN			1		
981			1	2	1

Contents

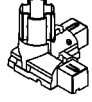
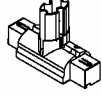
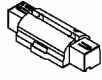
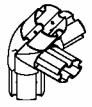
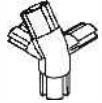
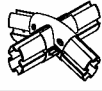
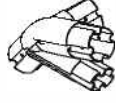
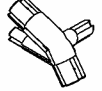
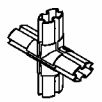
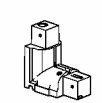
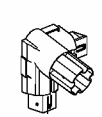
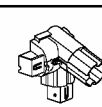
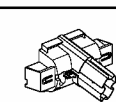
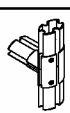

Item		Front	Back	Middle
PIN1		160	160	30
01		1	1	
2D		3	6	1
15		1		
53			1	
75		1		
51			4	2
76			1	
71		1		
10			1	
11		1	1	
12		1		
13			1	
14			2	1
09		4	2	
18		4		





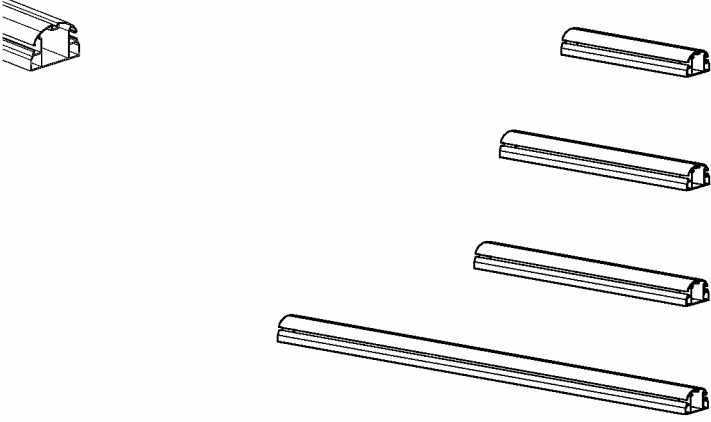
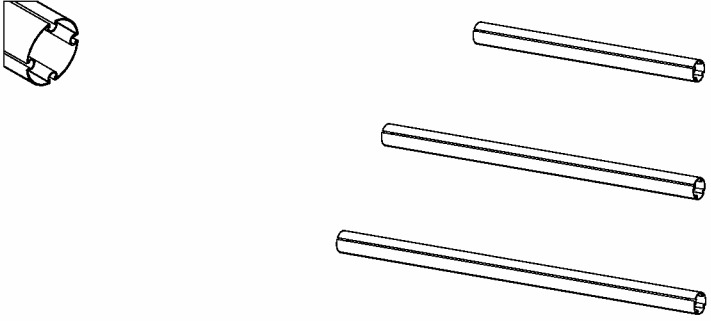
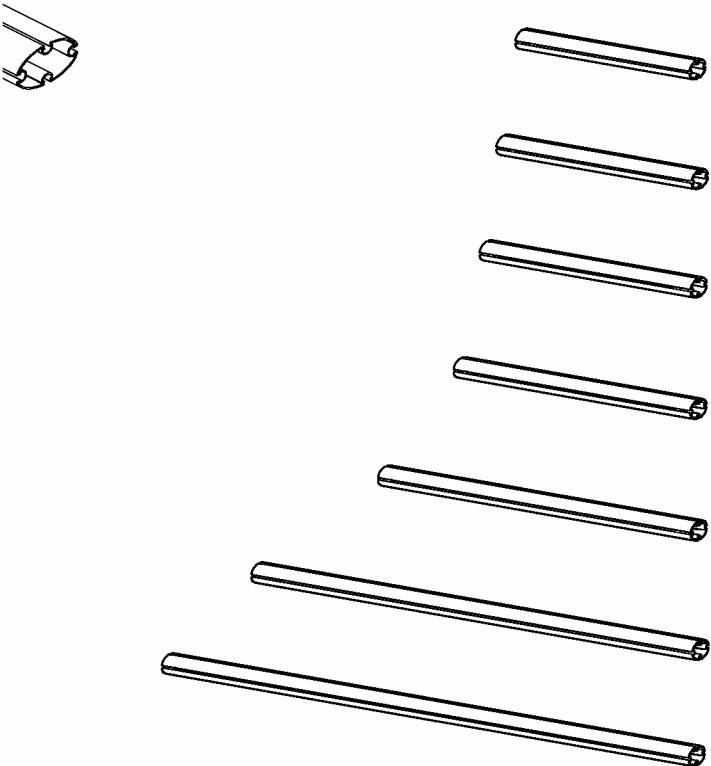









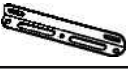

Contents



Item		Front	Back	Middle
Door 33		1		
B11		1	1	
B2		5	7	2
B12		1	1	
B1		1	1	
R1		1	1	
R11		1	1	
R10		1	1	
E100		3		
E102		2		
E2		5	8	2
E13		2	2	
E15			2	1
E1		4	4	1
E16			2	1

Contents

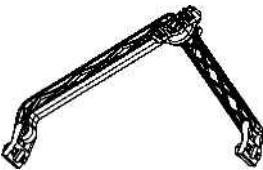











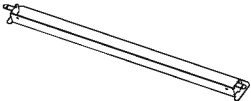

Item		Front	Back	Middle
SR1		1		
GT1		1	1	
7216		1		
7215		1		
7217		2		
7273		1		
7224		8		
4016		2		
466		8	2	
7279		2		
425		2		
7281		2		
4043		3	9	3
22			1	
99			1	
BC1		10	2	2
GF*		2	1	2

*only for clear Sun Room / Sun Lounge

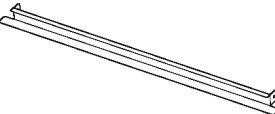
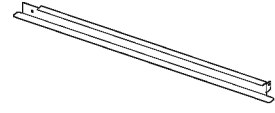
Contents



Item		Front	Back	Middle
992			2	
991			1	
989			1	
411			2	
4008			4	
7441			1	
7536			1	
7534			1	
7535			1	
7533			1	
7220			1	
SF			2	
465			4	
422			4	

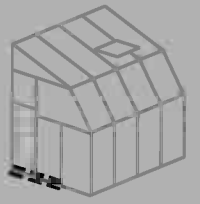

1 **i**

item		Qty.
B2		2
SR1		1
2D		1

item		Qty.
7217		1
466		2
7224		2

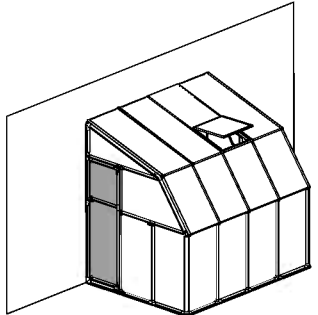
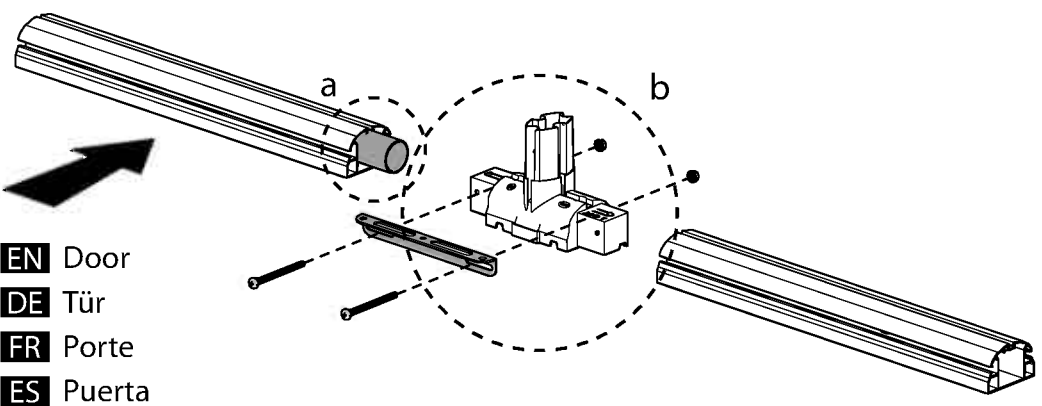
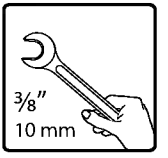
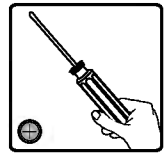



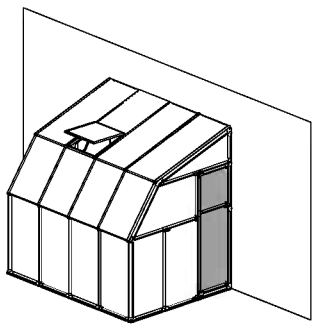
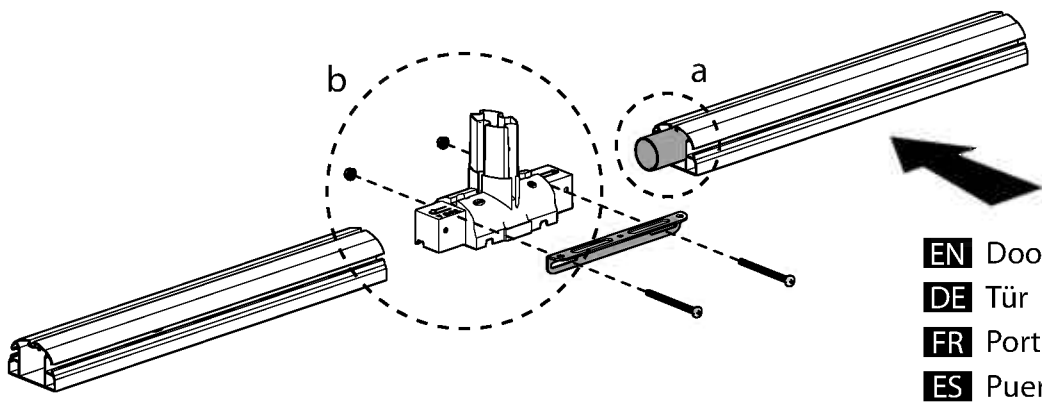
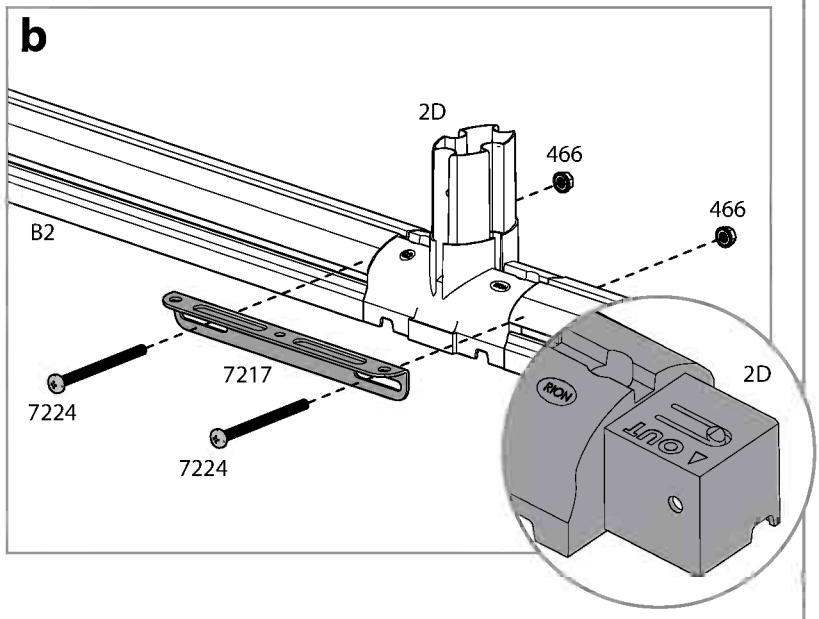
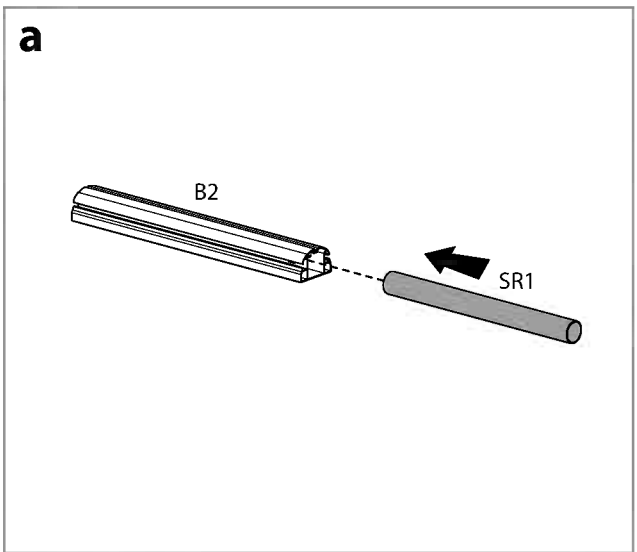

EN Door
DE Tür
FR Porte
ES Puerta

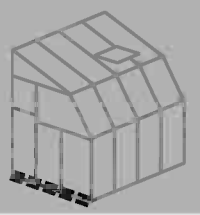

EN Door
DE Tür
FR Porte
ES Puerta

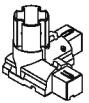

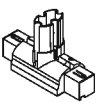
Item		Qty.	Item		Qty.
B2		1	11		1
01		1	pin1		8
2D		1			

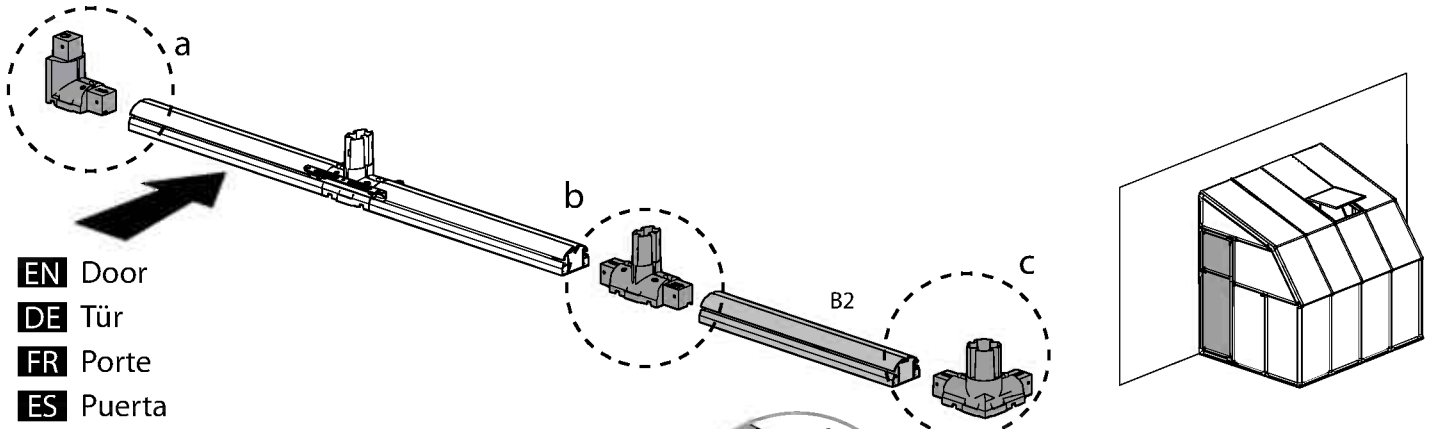
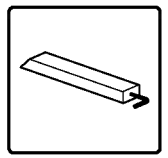

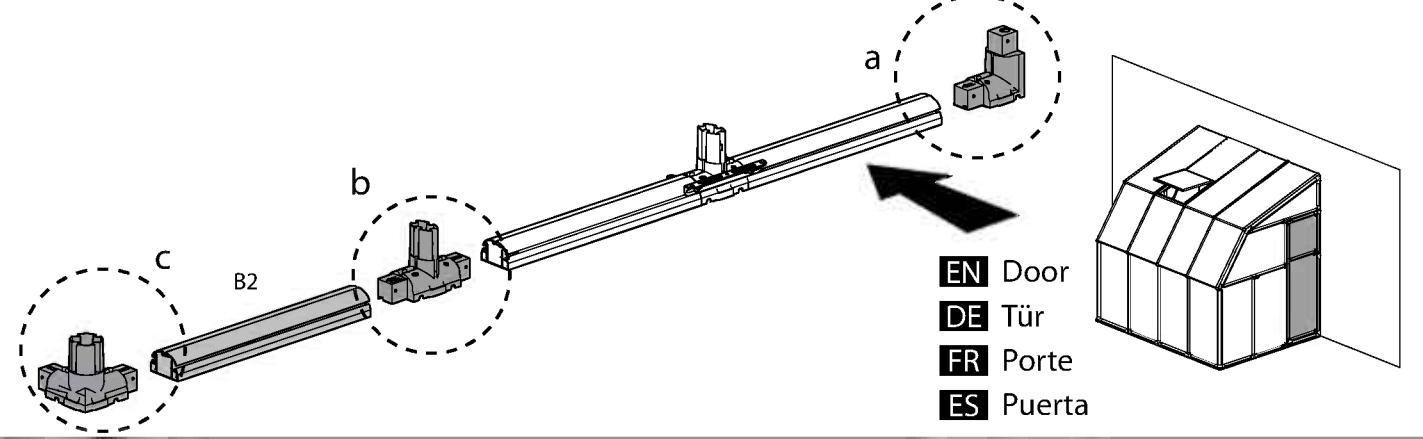
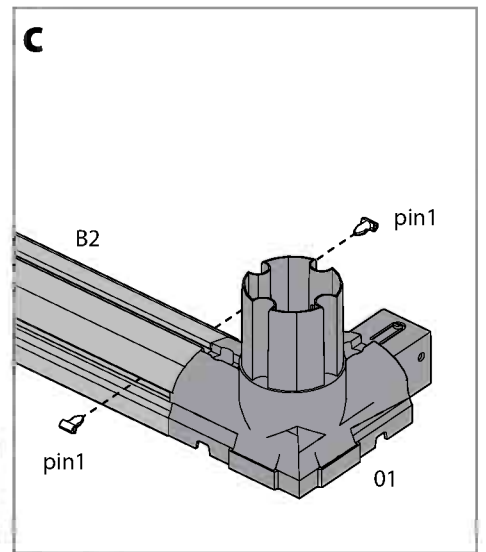
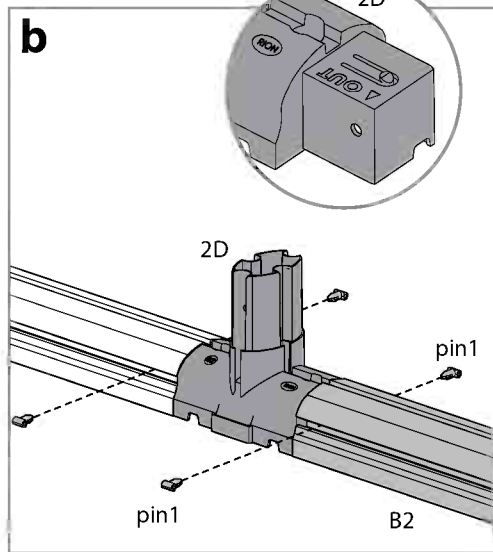
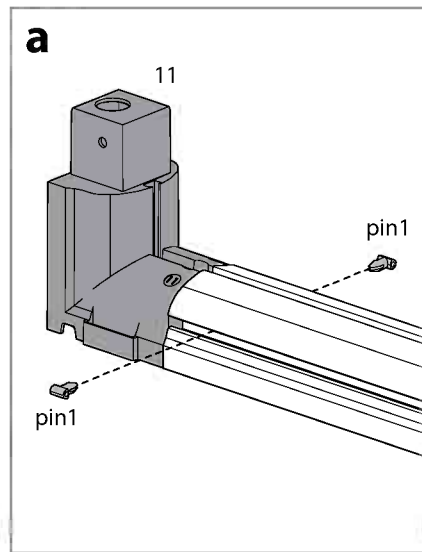

- EN** Door
- DE** Tür
- FR** Porte
- ES** Puerta

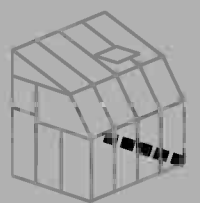

- EN** Door
- DE** Tür
- FR** Porte
- ES** Puerta

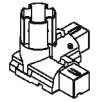
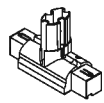

Item		Qty.
B2		3
01		1
2D		2

Item		Qty.
11		1
pin1		12

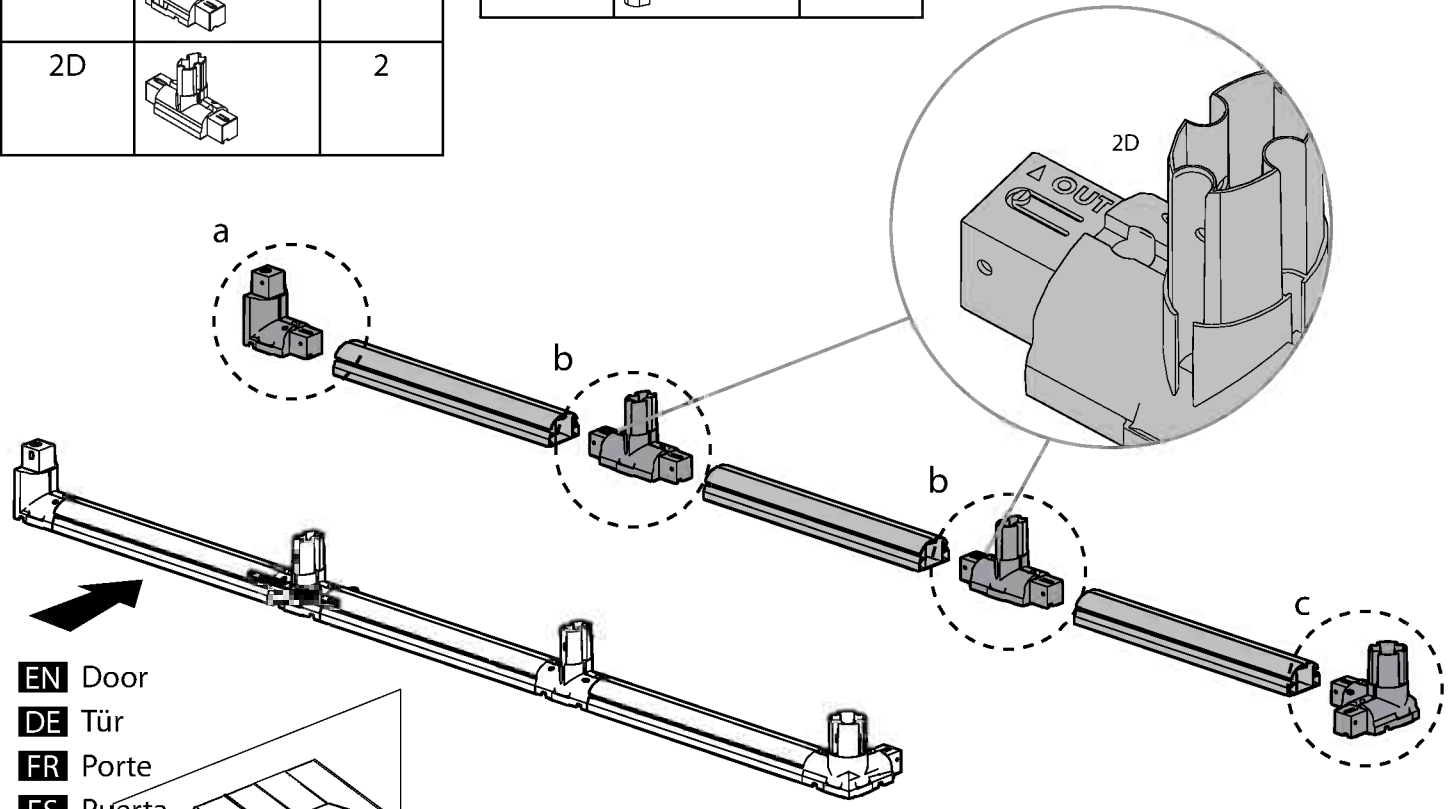
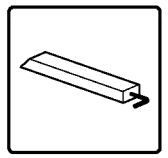

- EN** Door
- DE** Tür
- FR** Porte
- ES** Puerta

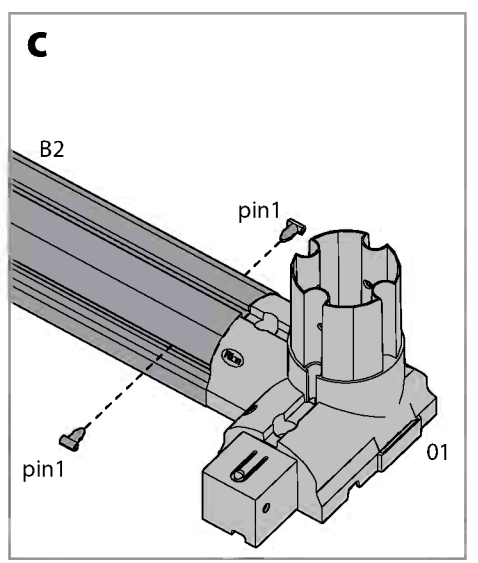
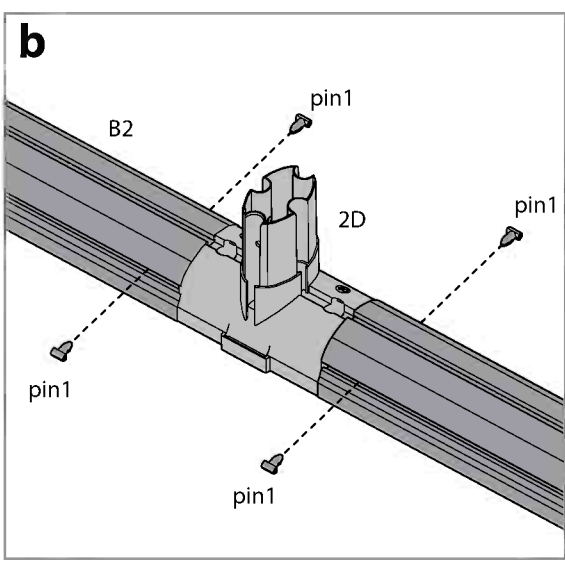
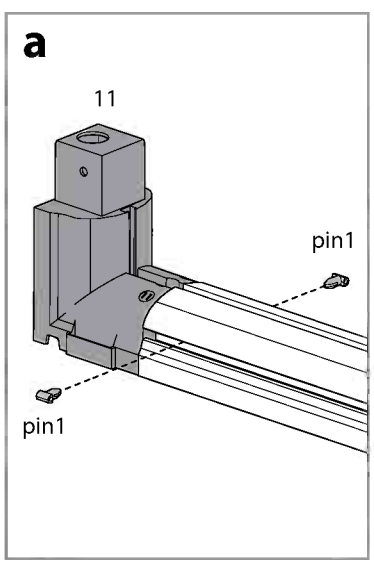
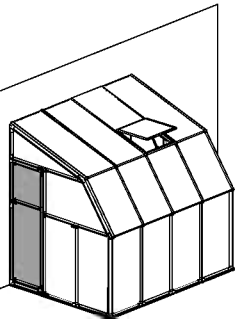

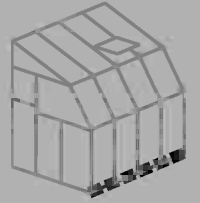
4

Item		Qty.
B2		4
2D		3
pin1		16



6'x8' = 4xB2

6'x10' = 5xB2

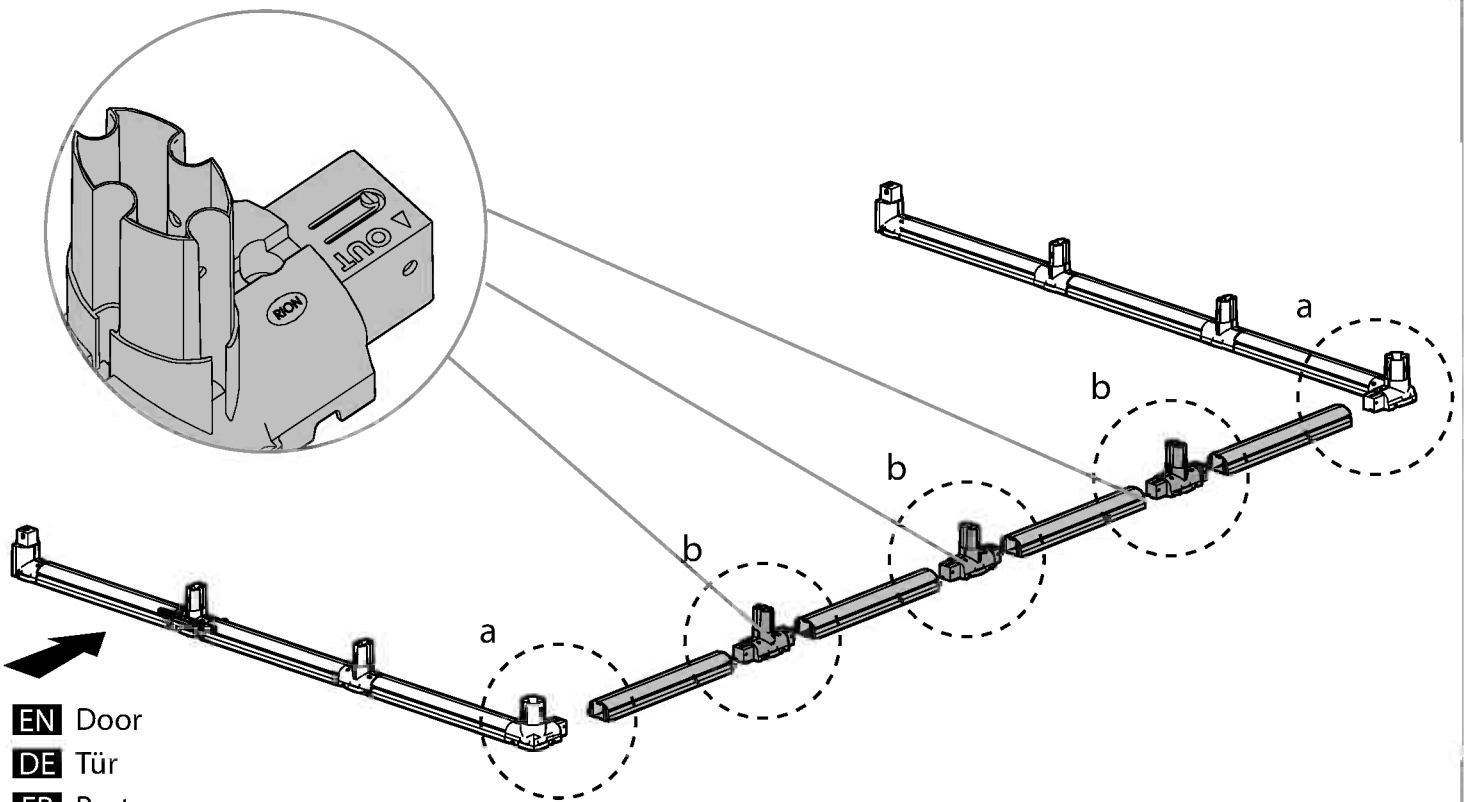
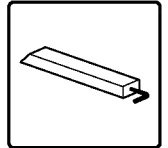

- EN** Door
- DE** Tür
- FR** Porte
- ES** Puerta

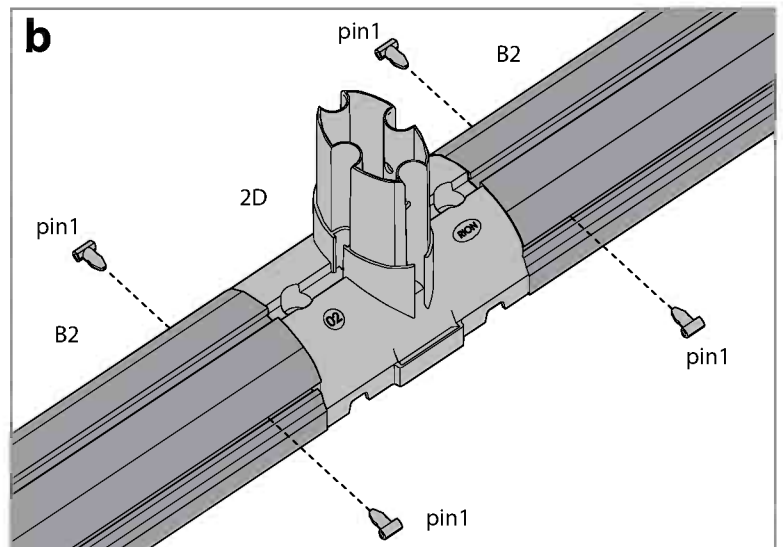
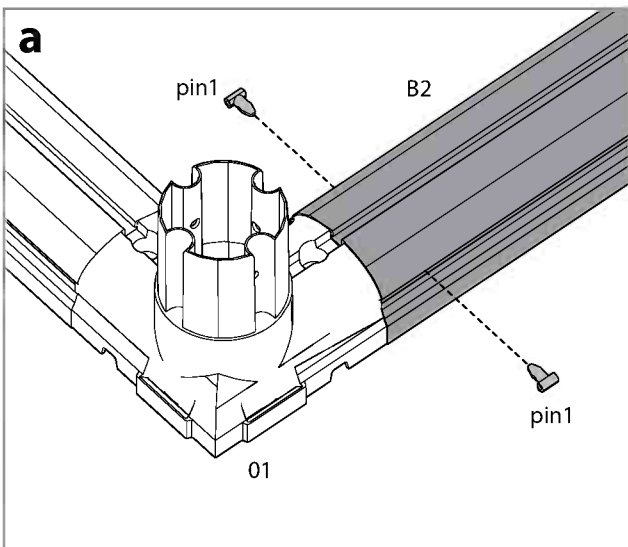

5

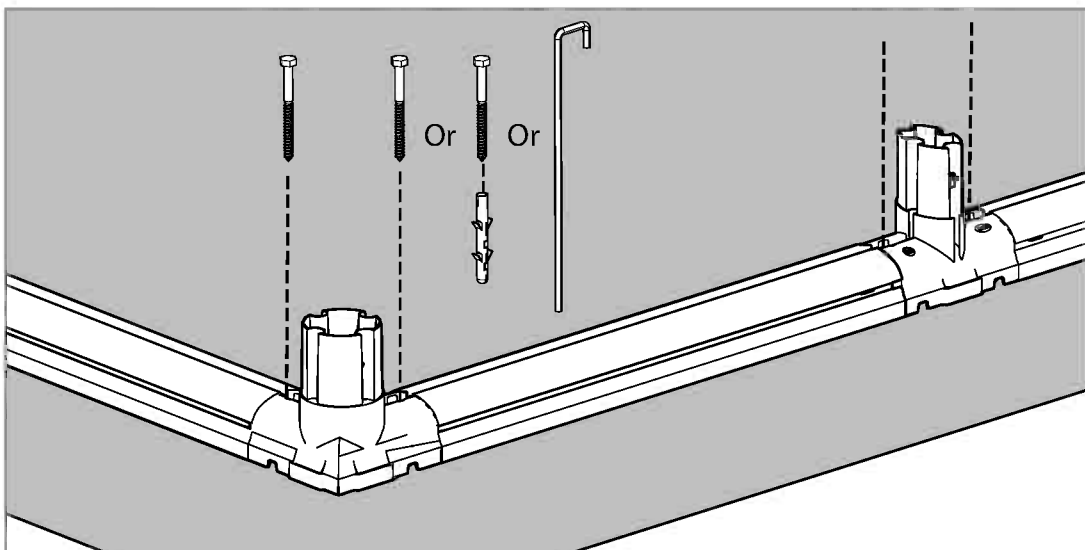
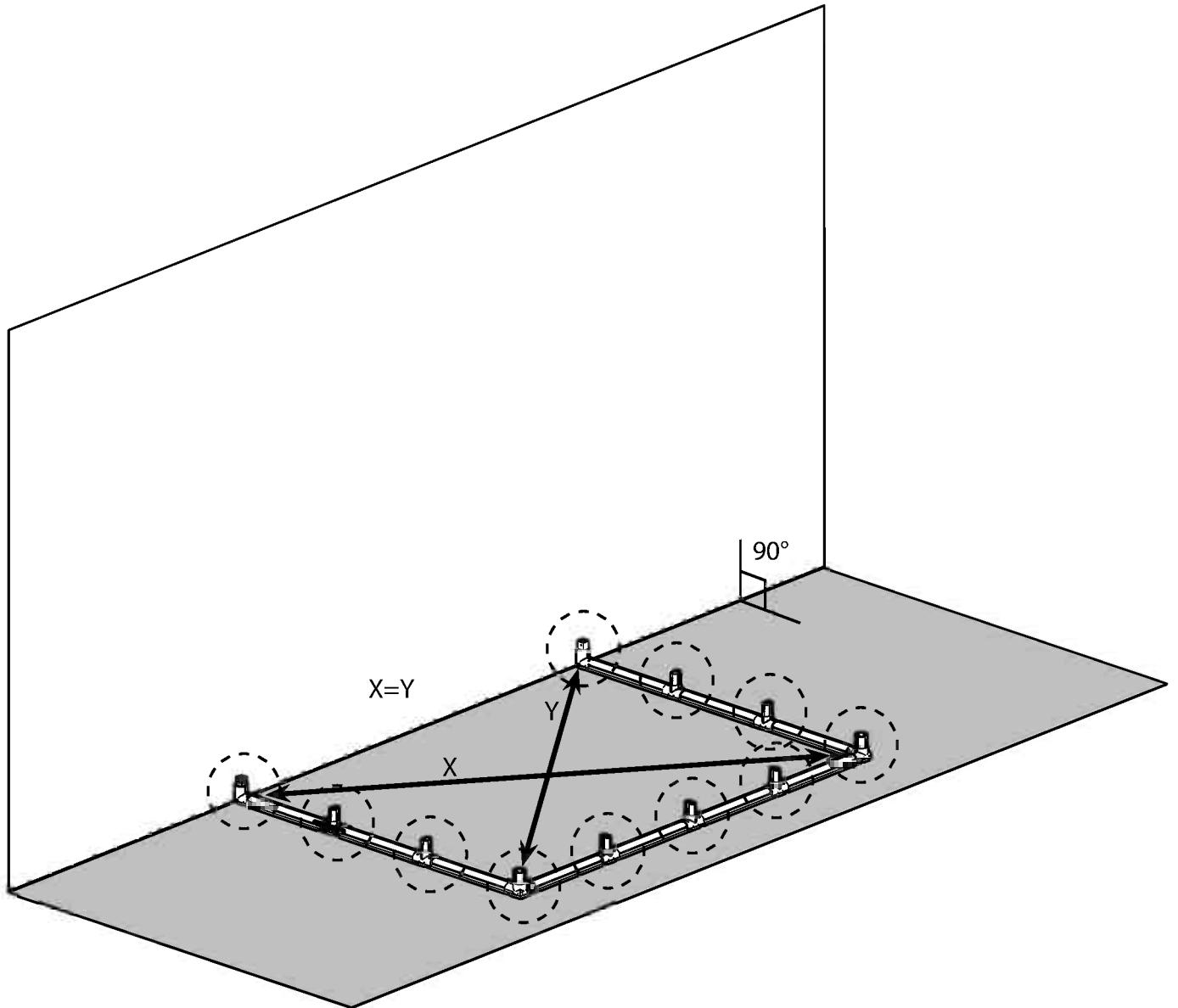
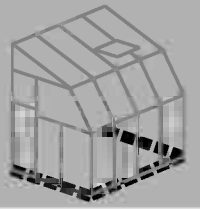



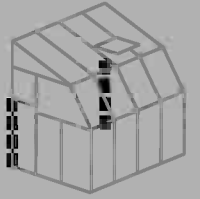

6

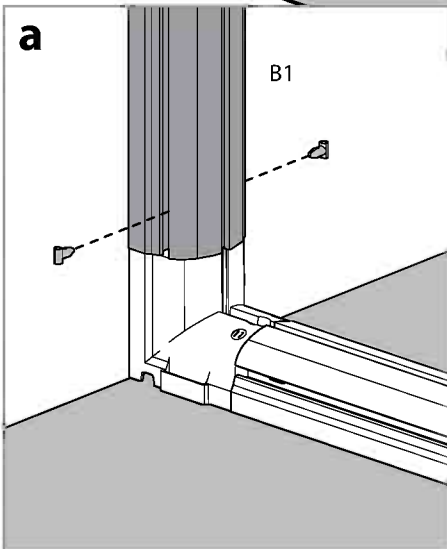
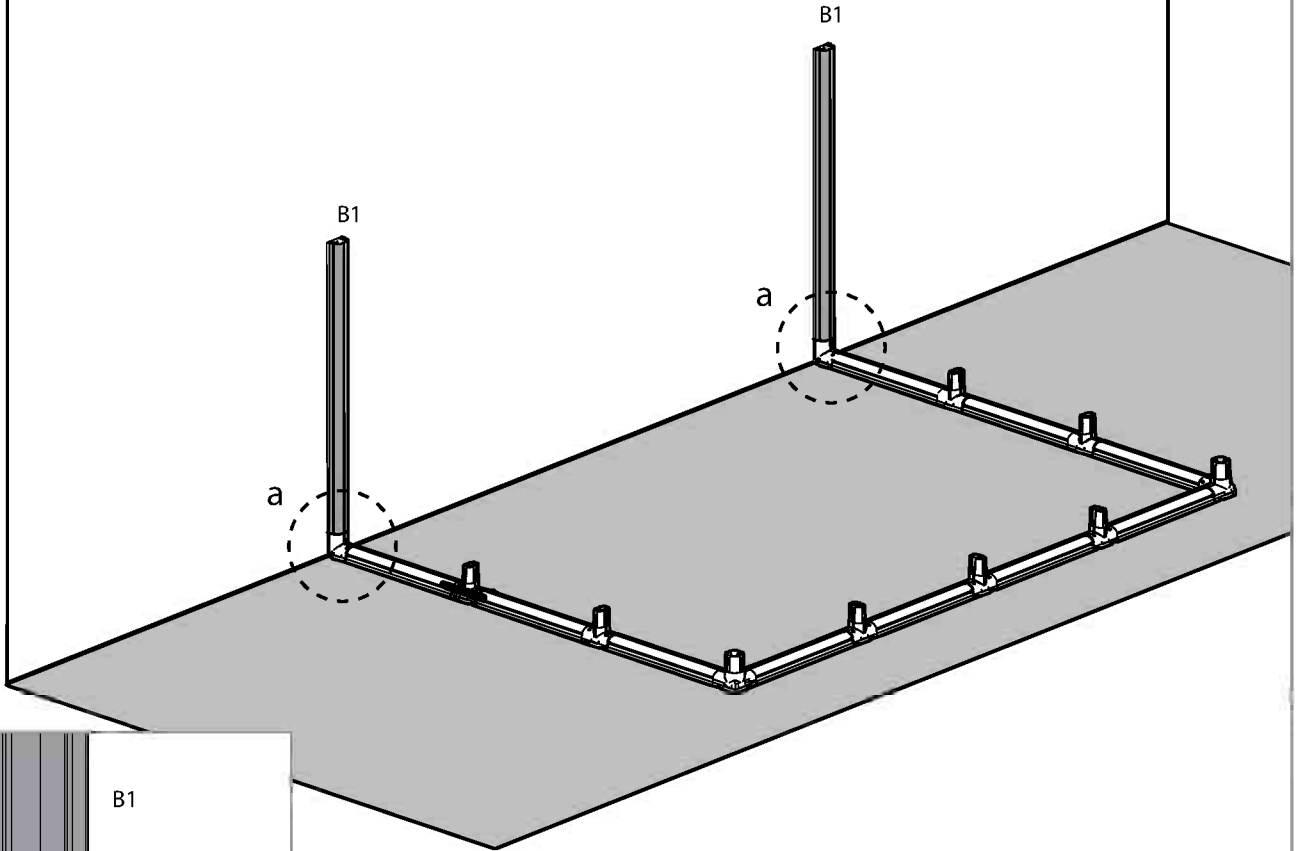
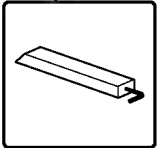

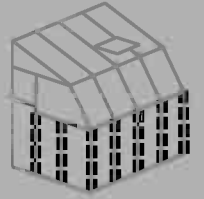
Item		Qty.
B1		2
pin1		4





Item		Qty.
E1		7
R1		2
pin1		18

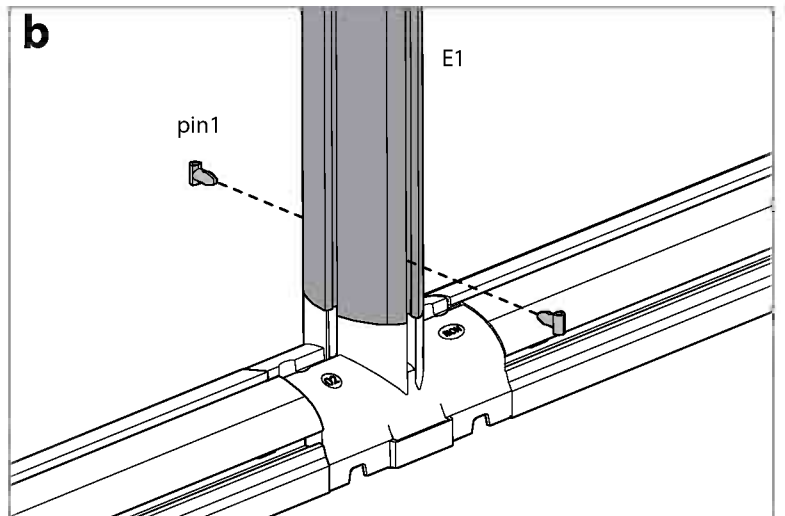
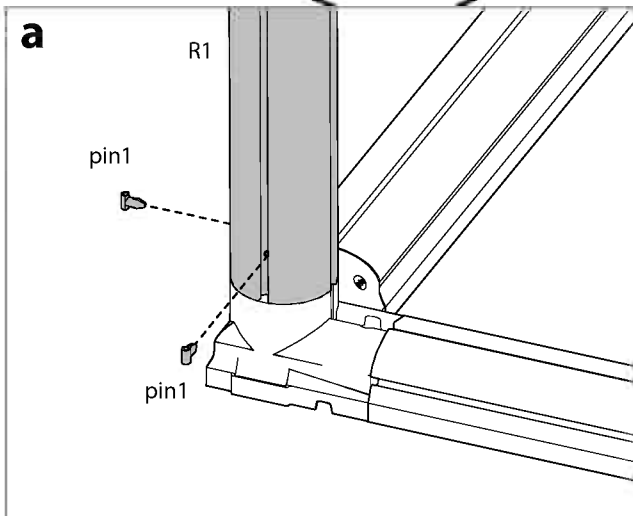
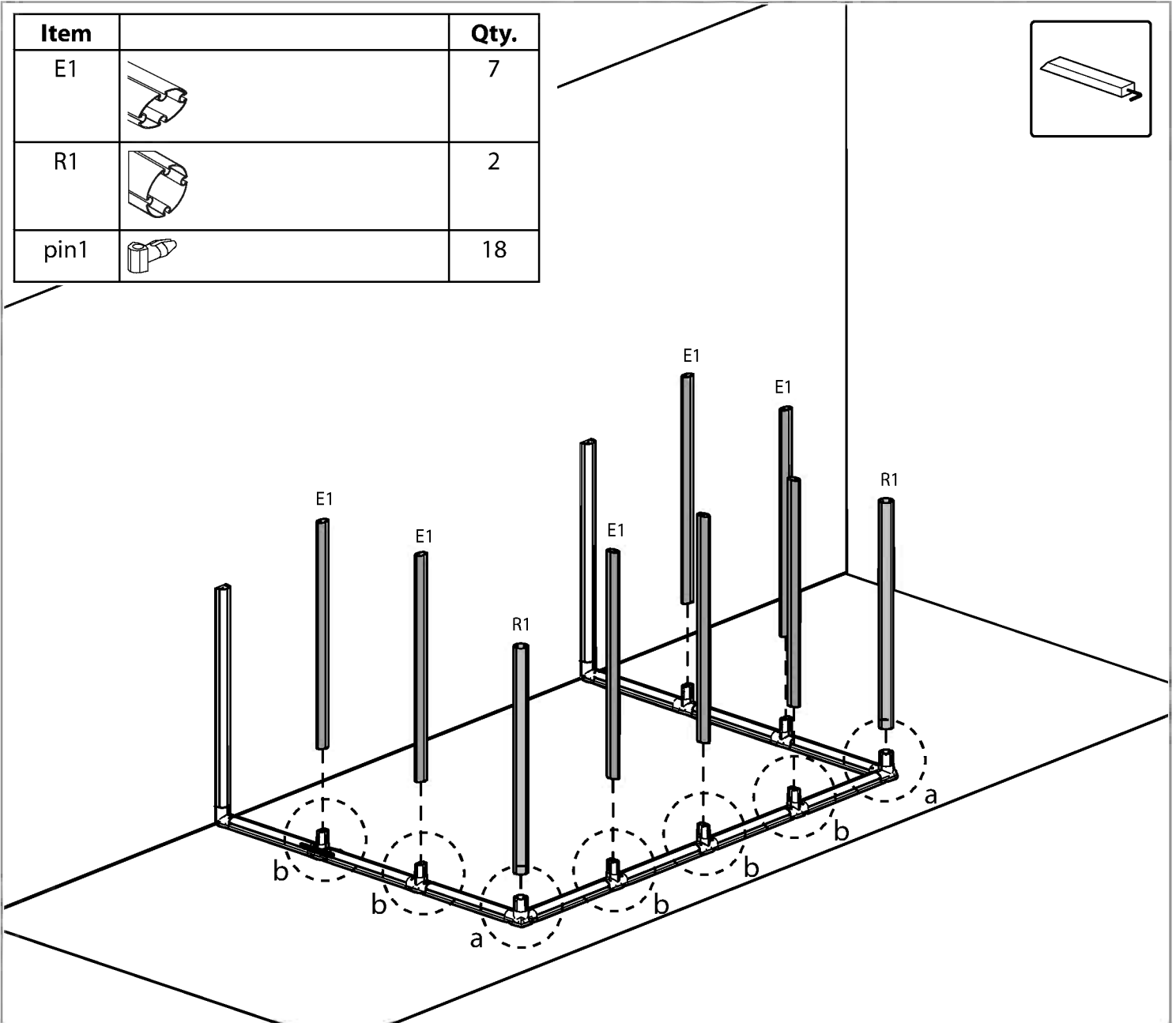
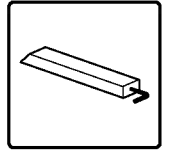

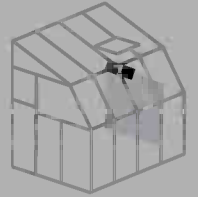

Item		Qty.
10		1
2D		1
E2		1
7539 / PN1		2
pin1		8

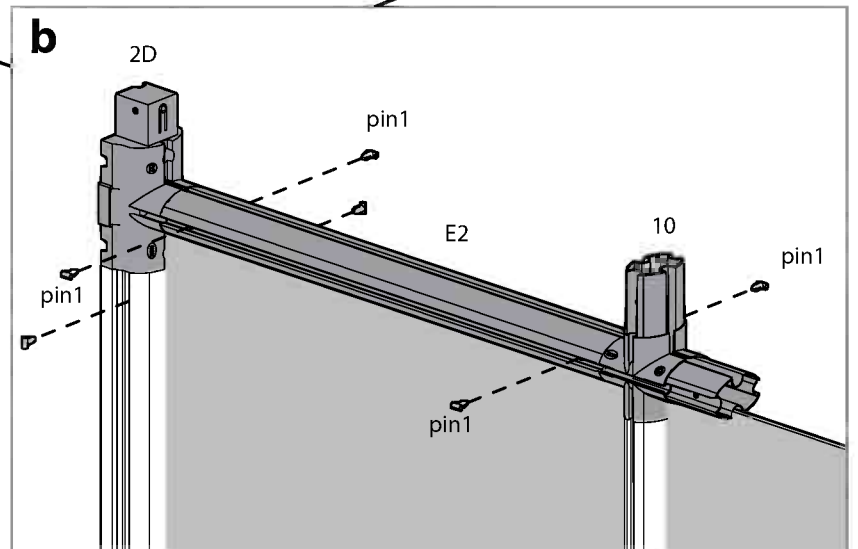
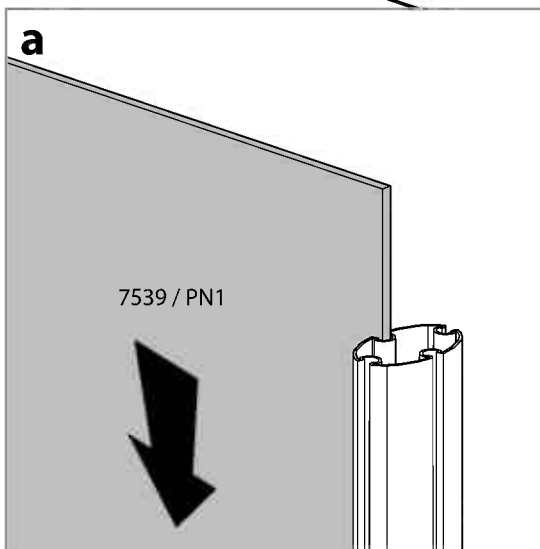
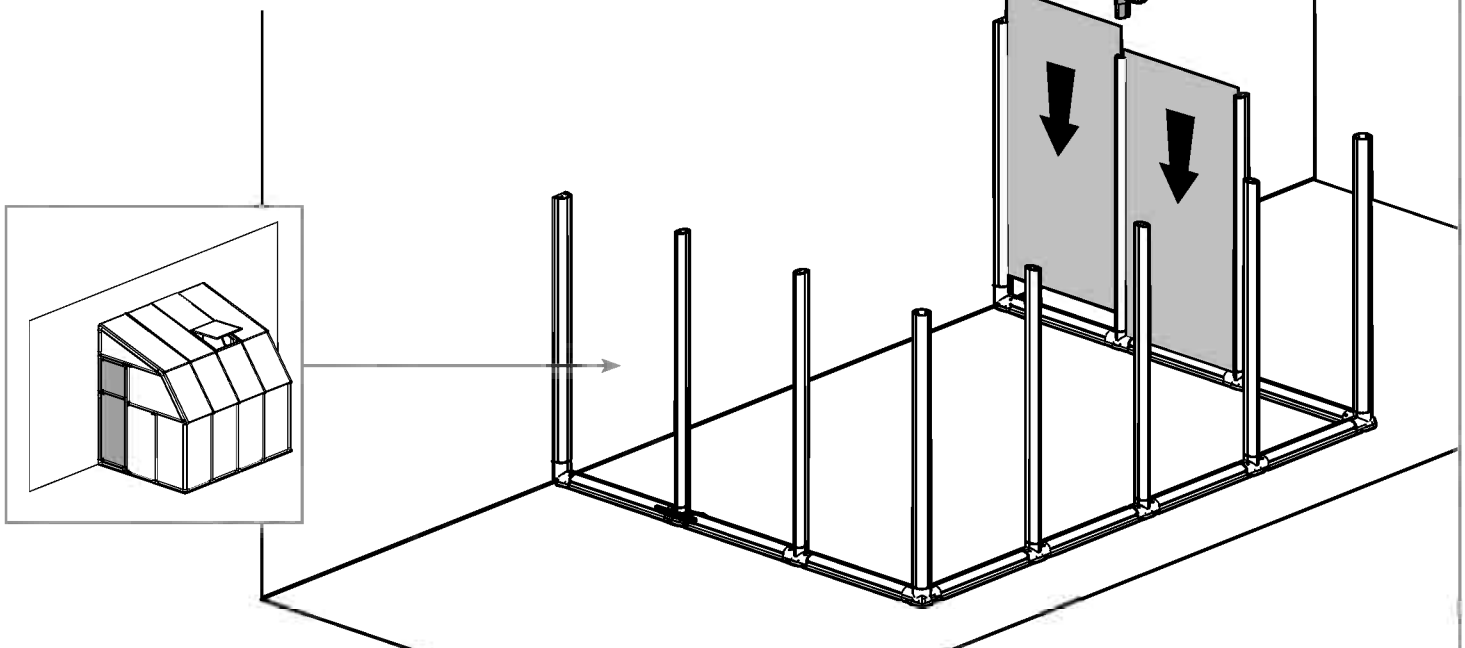
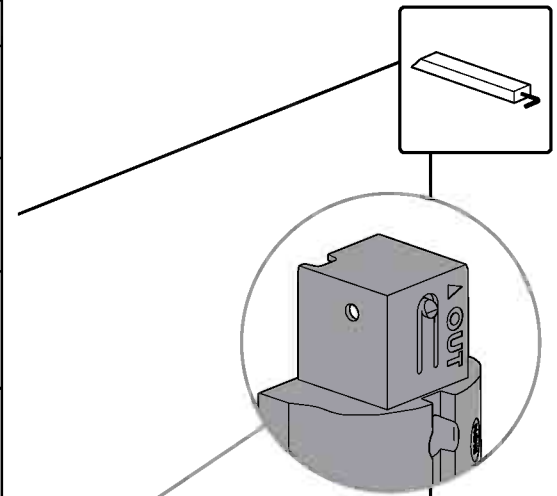



Item		Qty.
51		3
09		2
75		1
E2		6
7539 / PN1		5
pin 1		36

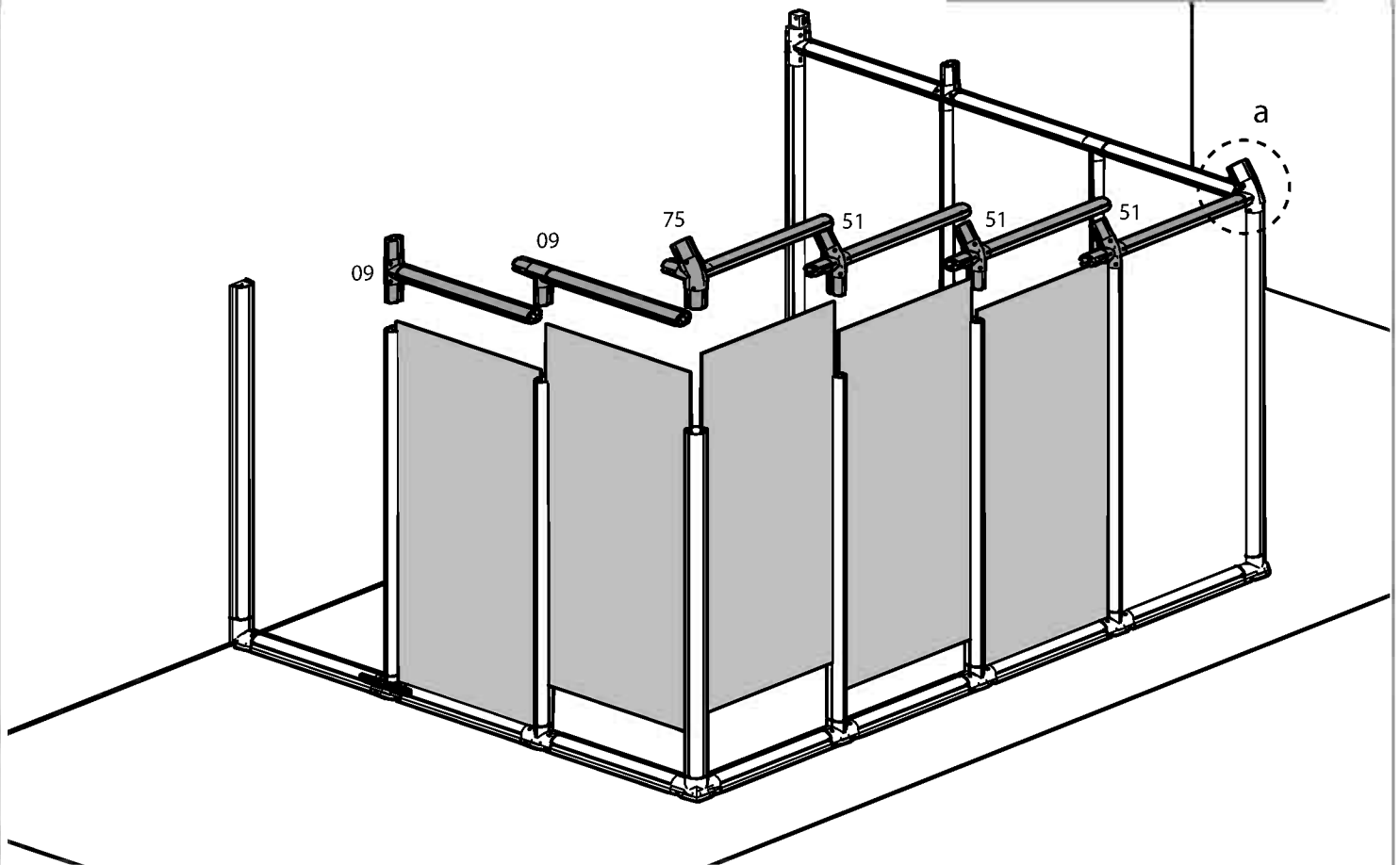
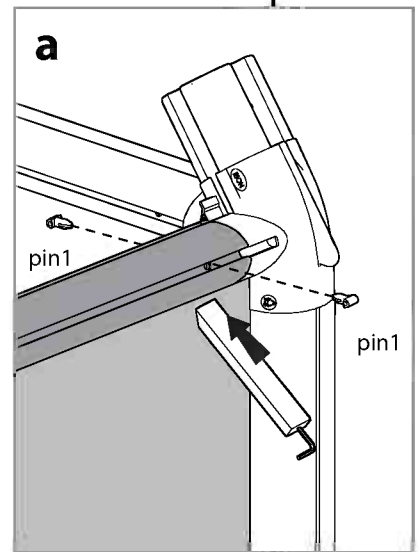
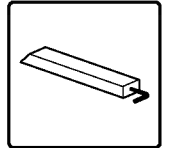

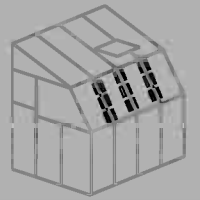

Item		Qty.
E15		3
pin1		6

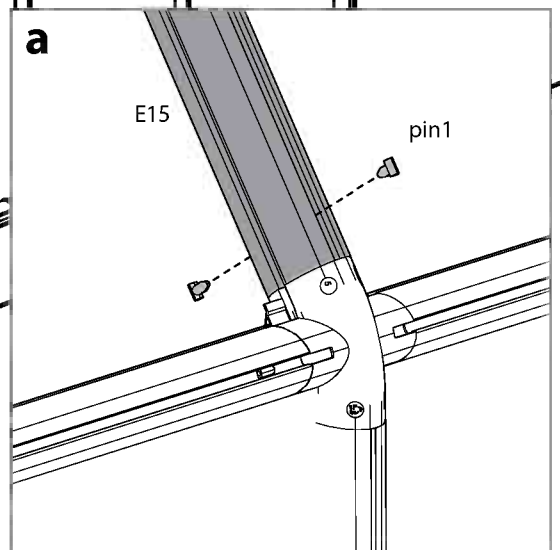
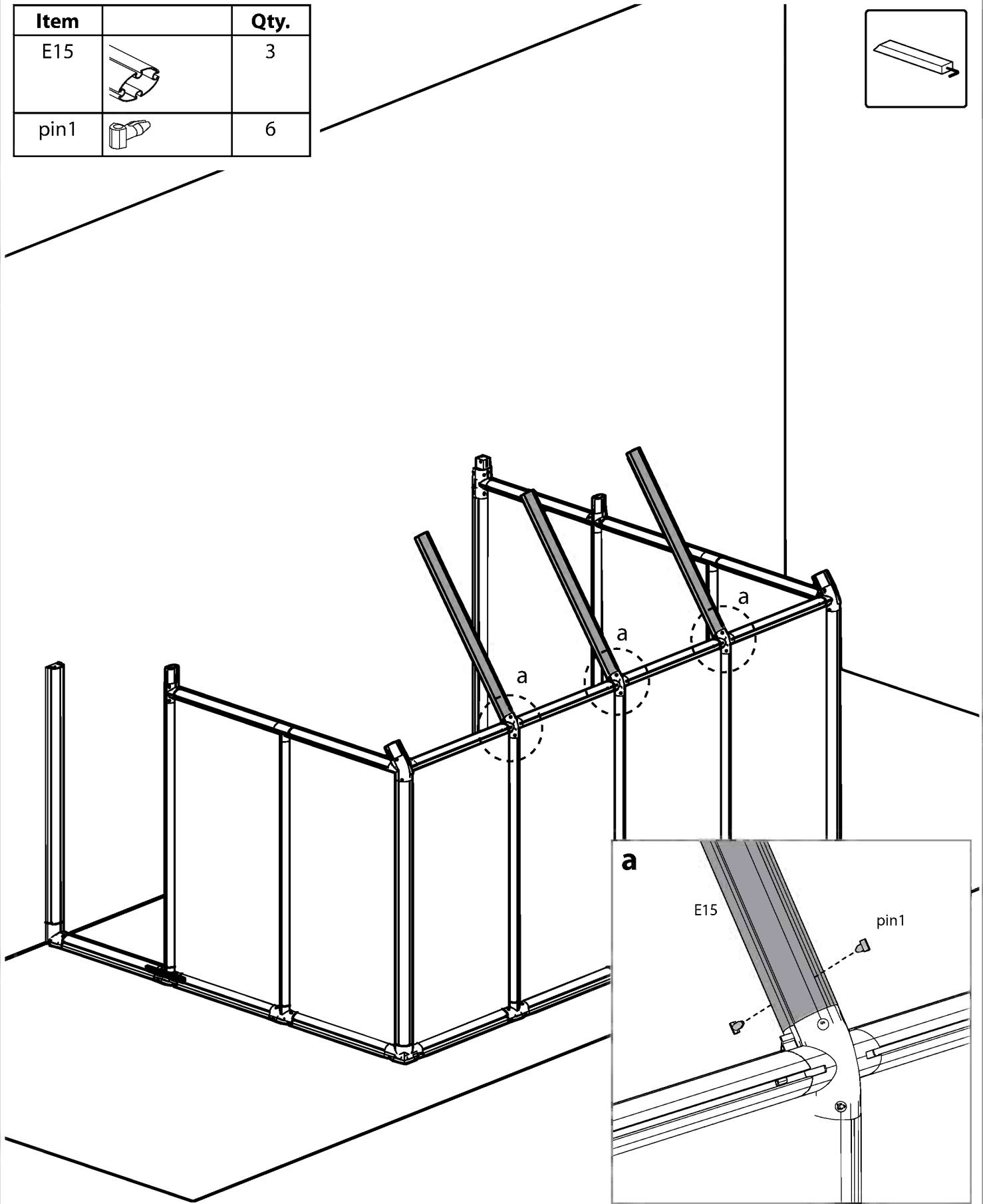
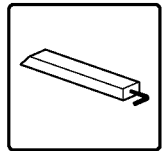

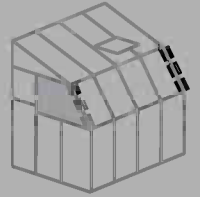

Item		Qty.
R10		2
7620/ PN51		1
7619/ PN51		1
pin1		4

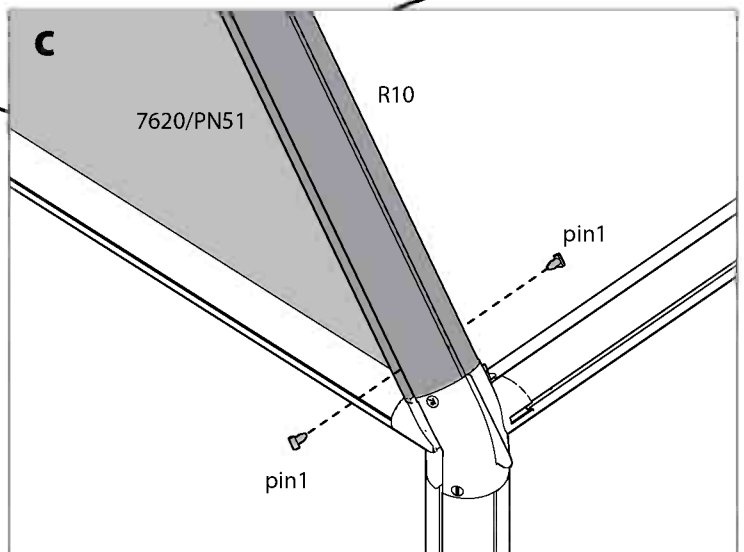
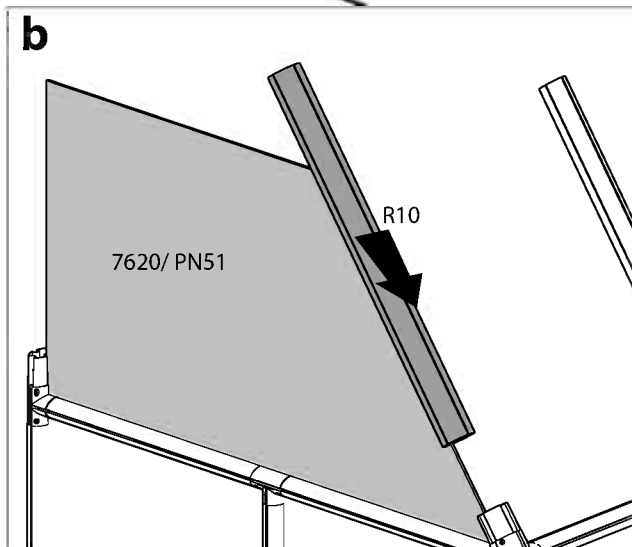
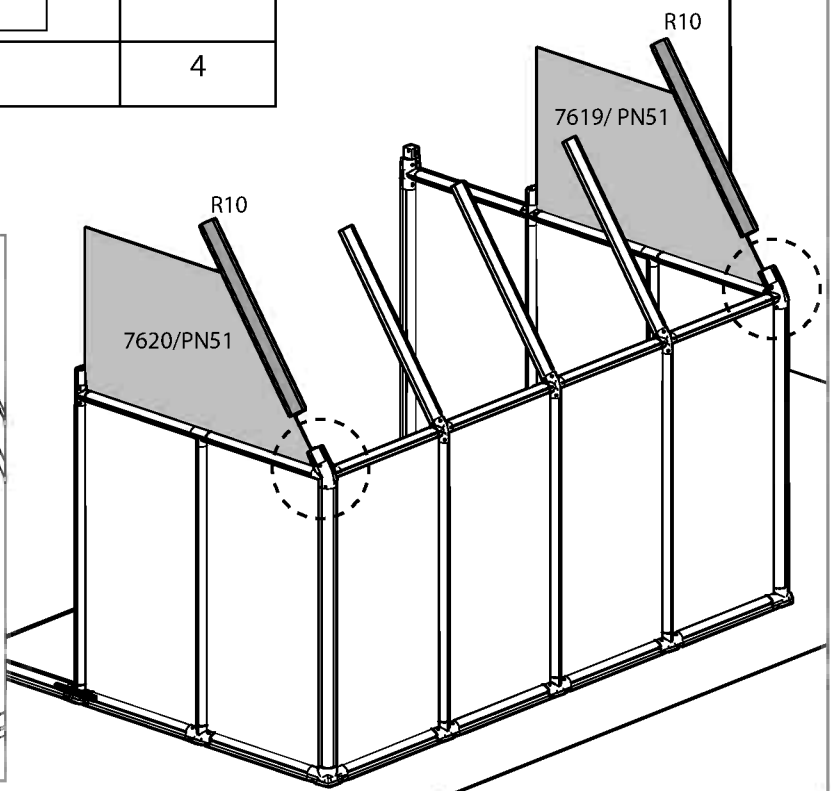
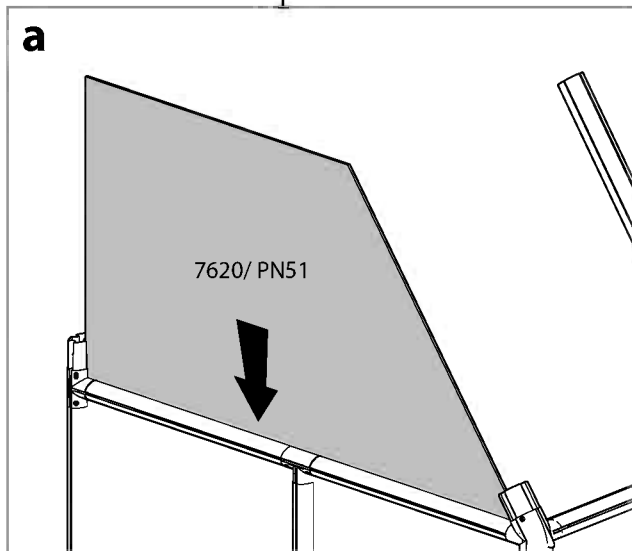
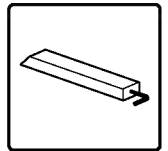

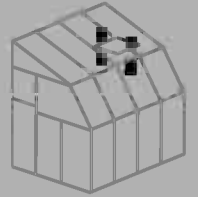

Item		Qty.
E13		1
B12		1
pin1		4
7628/ PN53		1

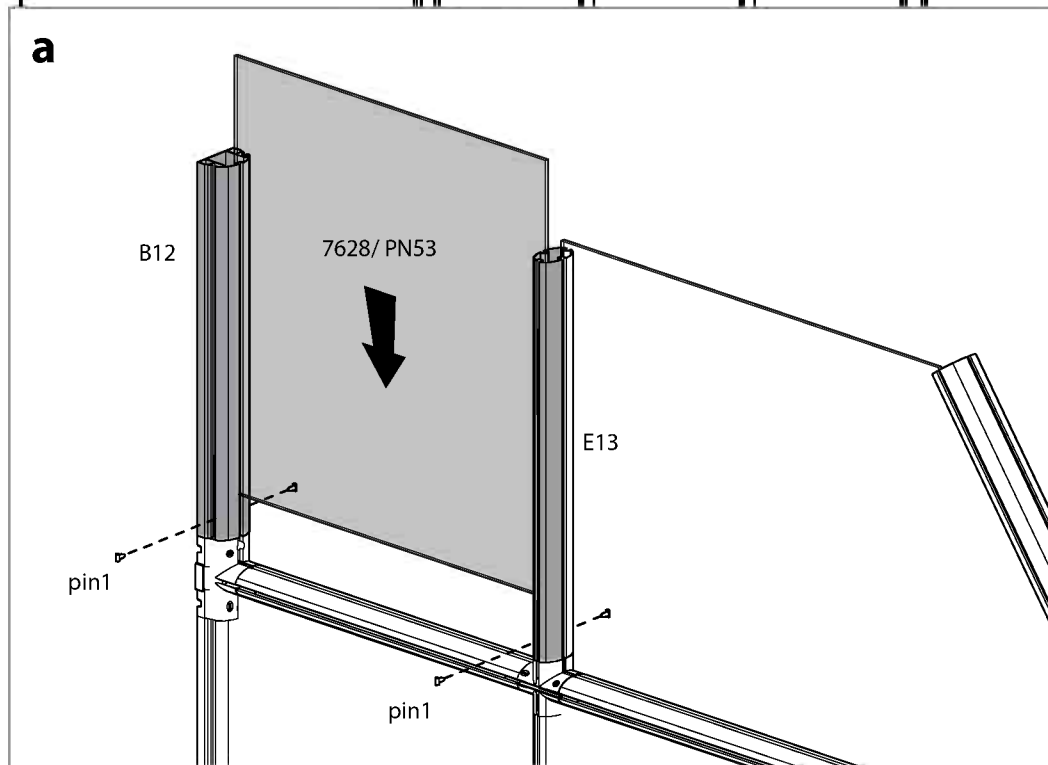
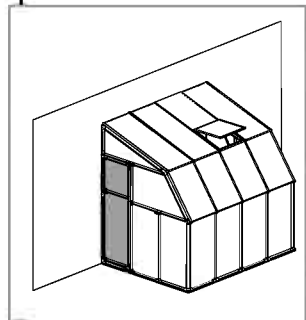
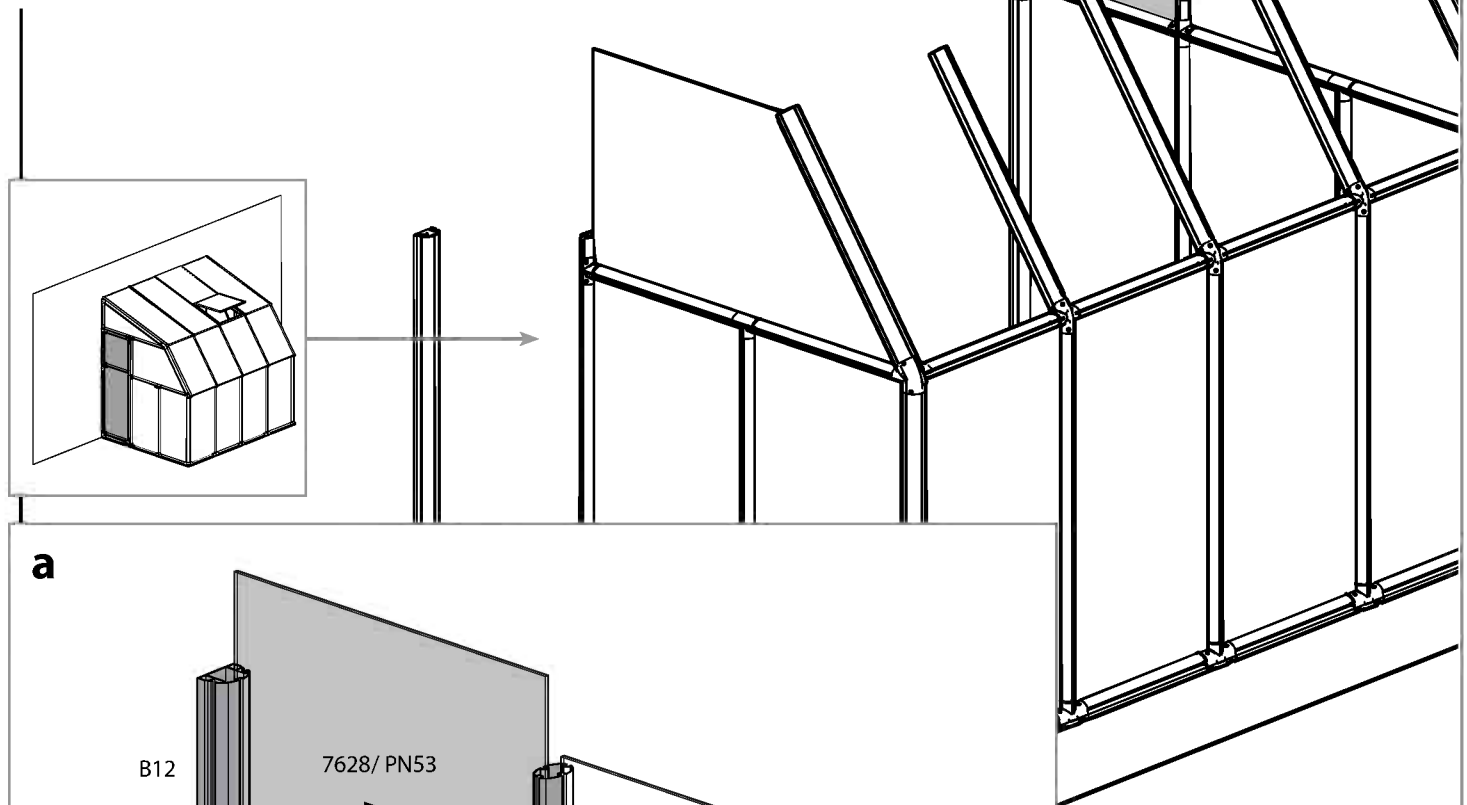
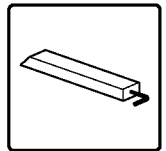

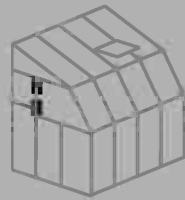

Item		Qty.
E13		1
B12		1
15		1
pin1		6

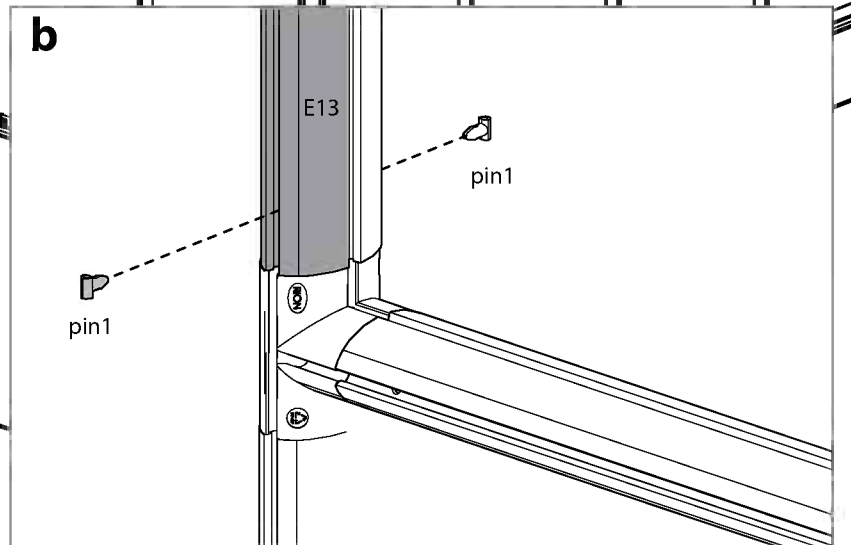
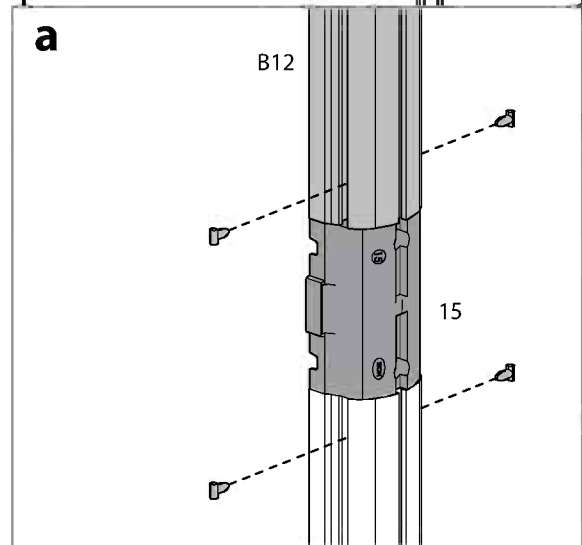
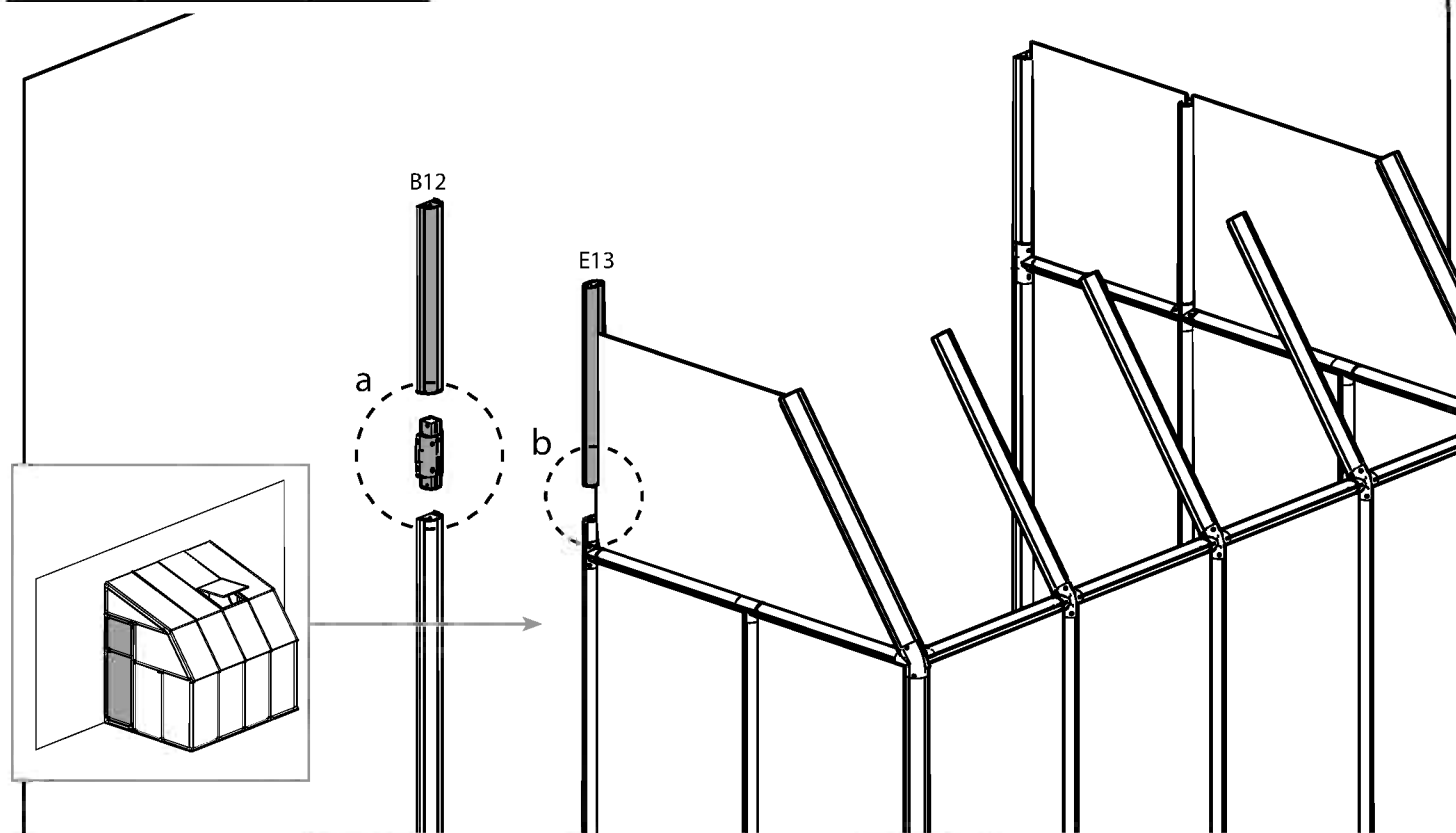
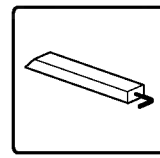

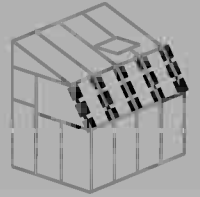

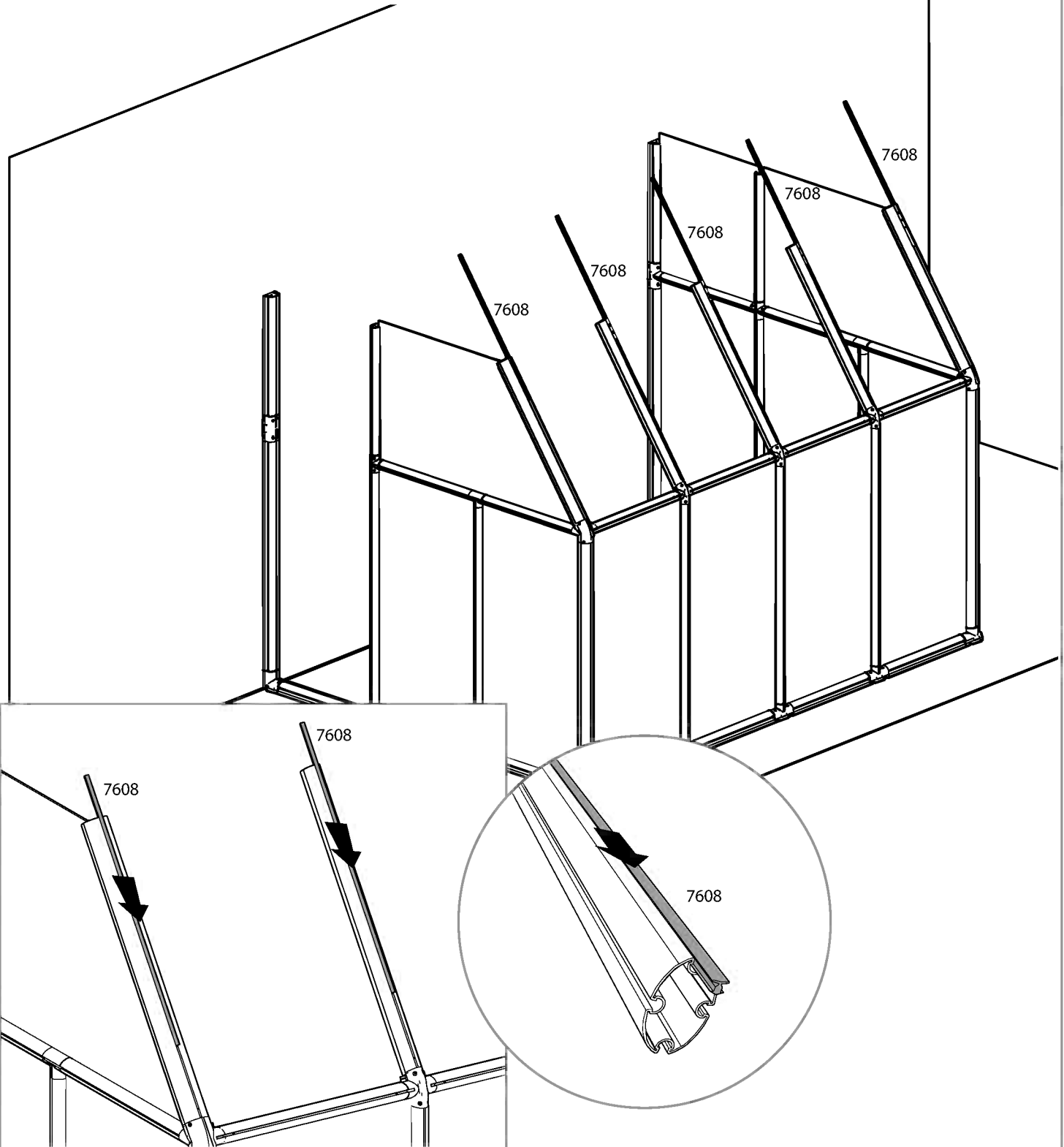

Item		Qty.
7608		5

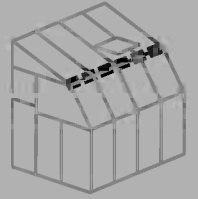

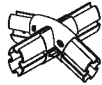

Item		Qty.
E2		4
51		3
pin1		18

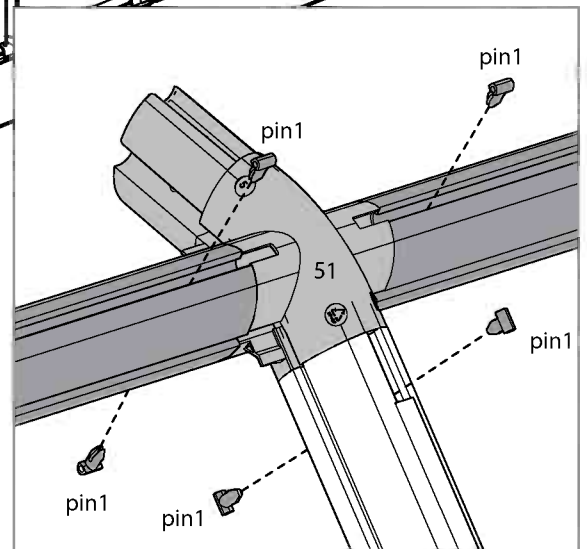
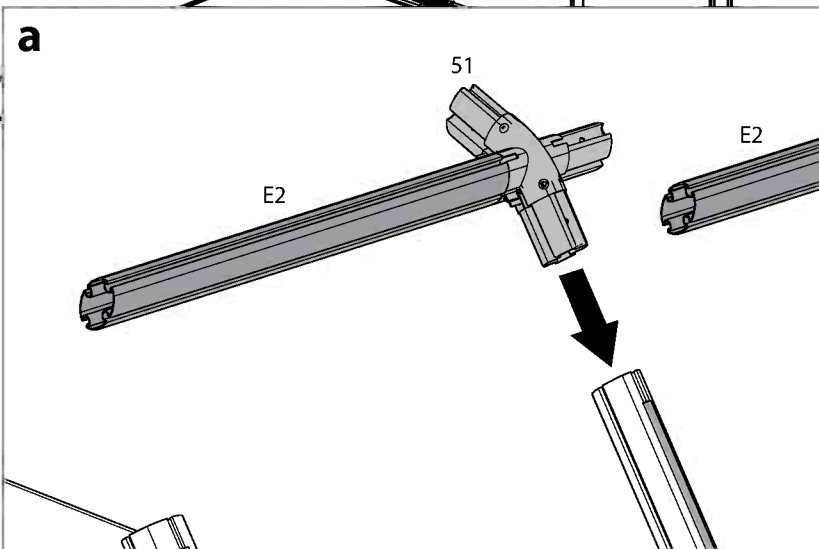
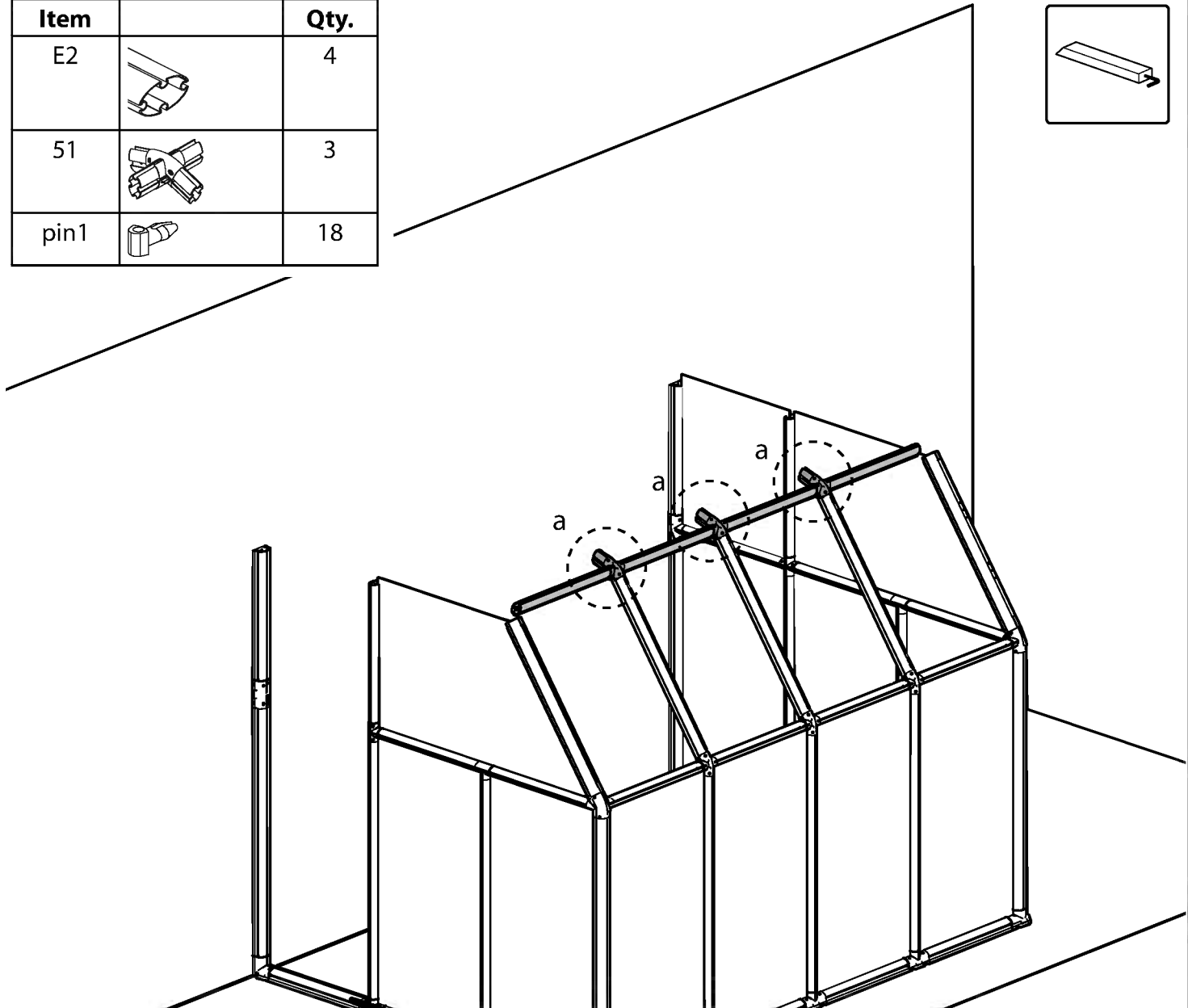
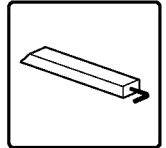

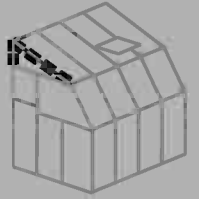





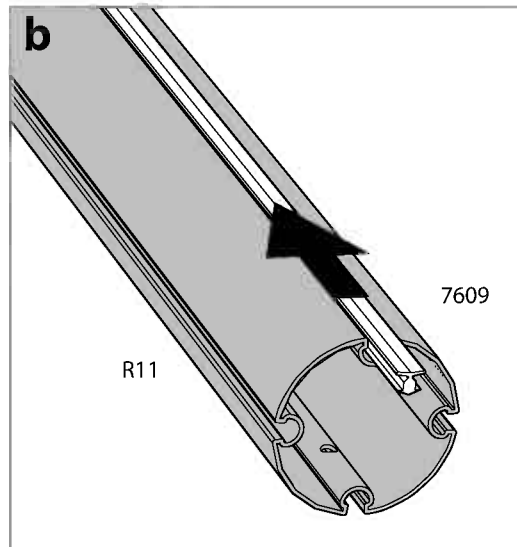
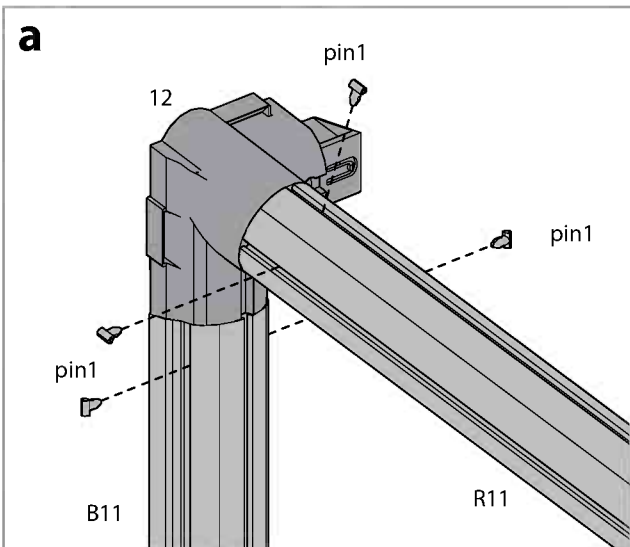
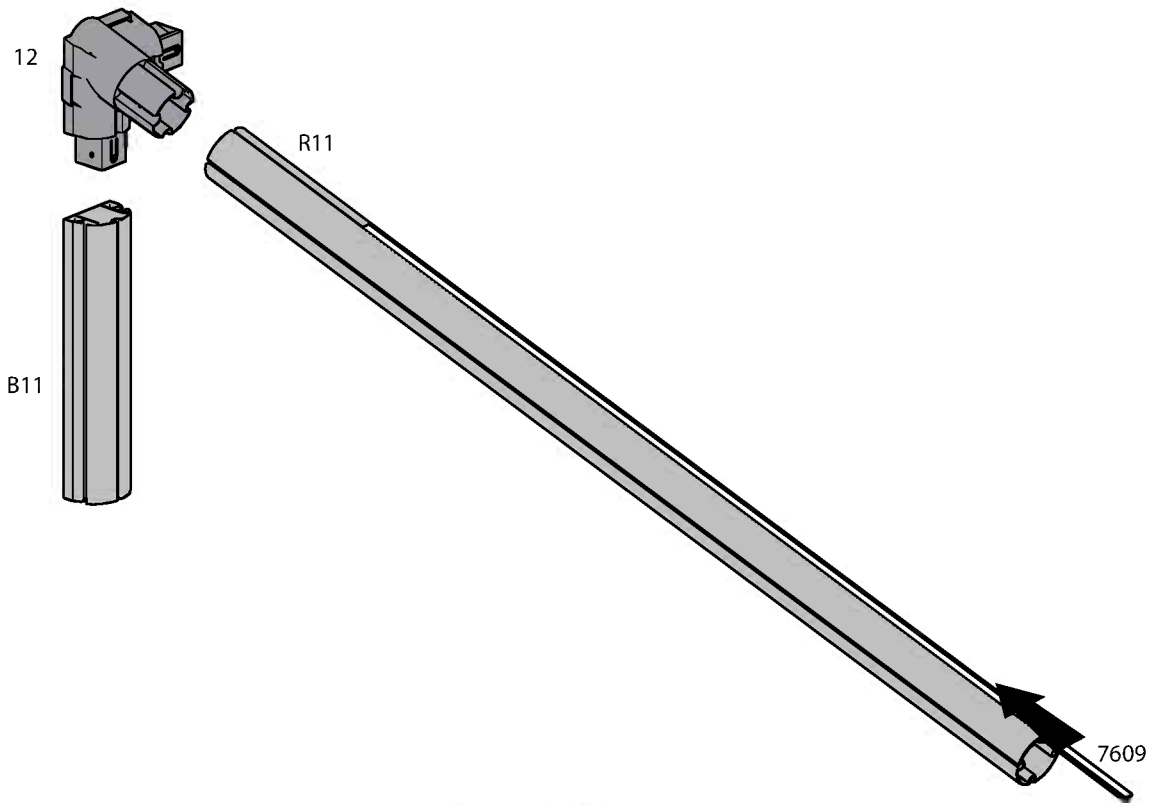
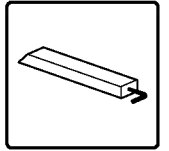

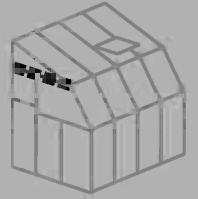

Item		Qty.
R11		1
B11		1
7609		1

Item		Qty.
12		1
pin1		5







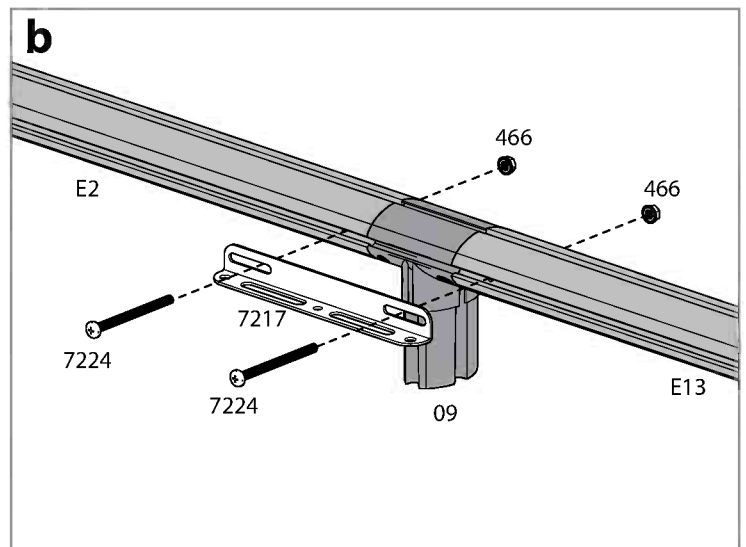
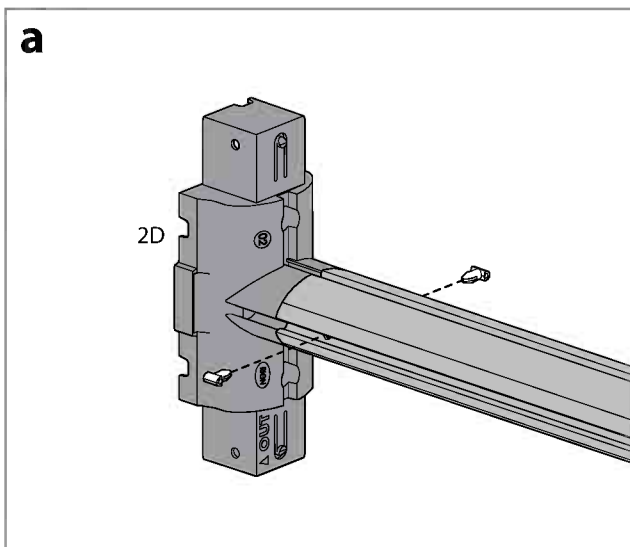
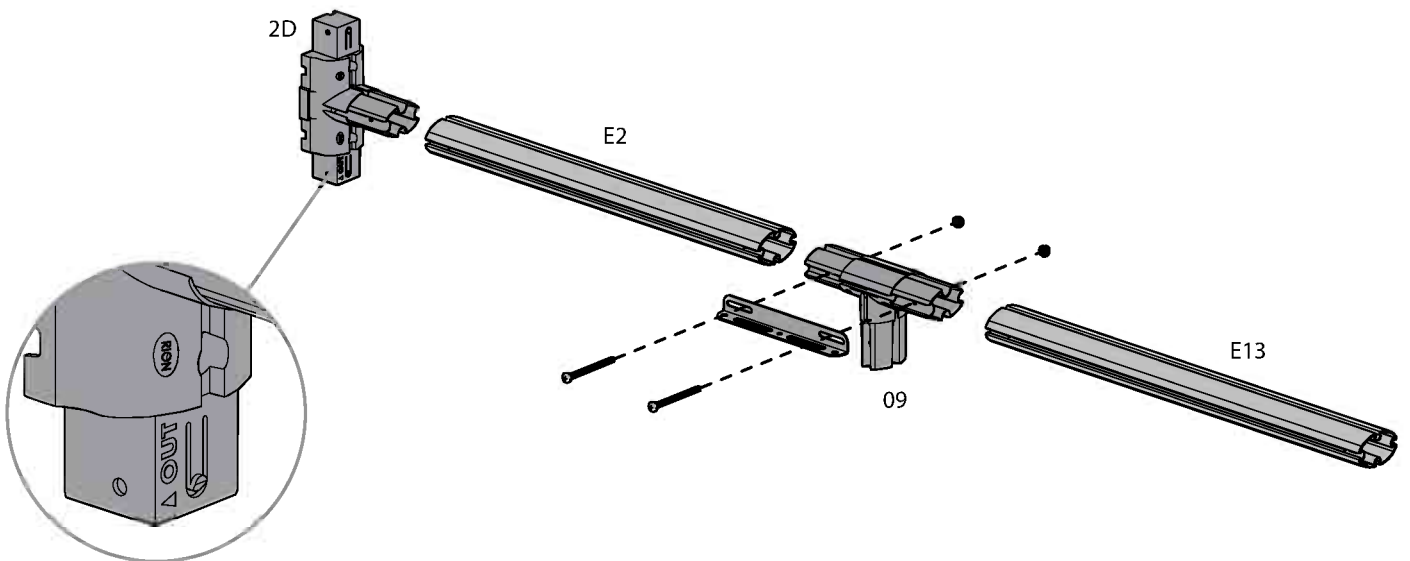

Item		Qty.
2D		1
09		1
E2		1
E13		1

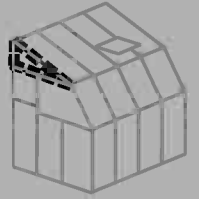
Item		Qty.
7224		2
7217		1
466		2
pin1		2



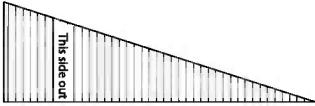

Item		Qty.
71		1
7618		1
pin1		6

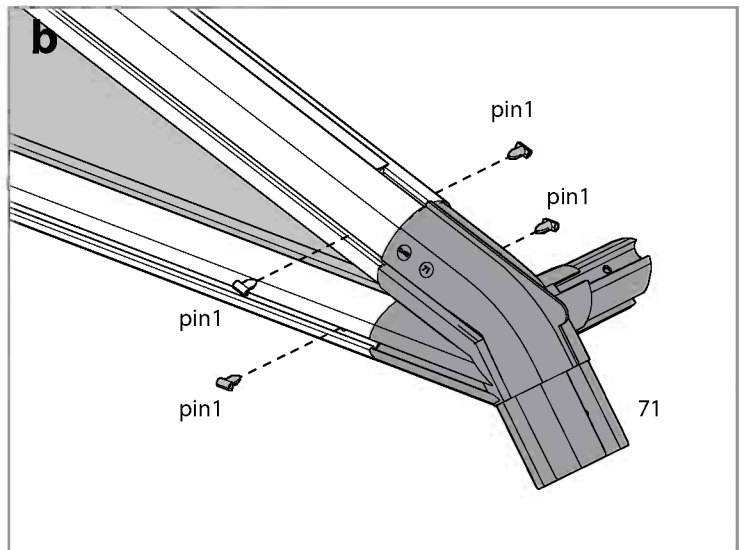
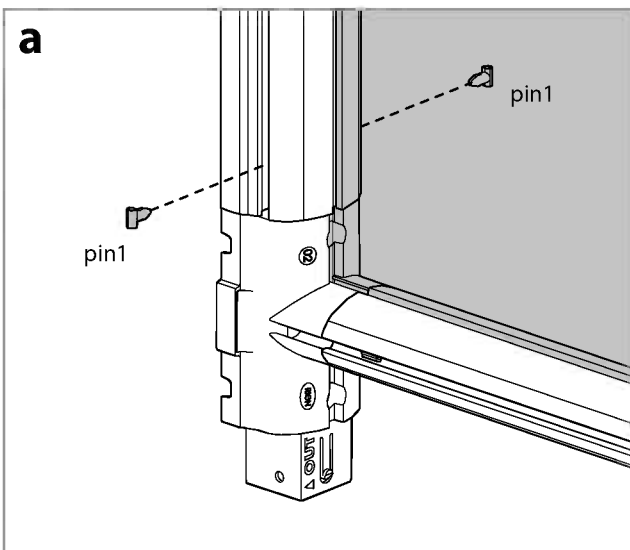
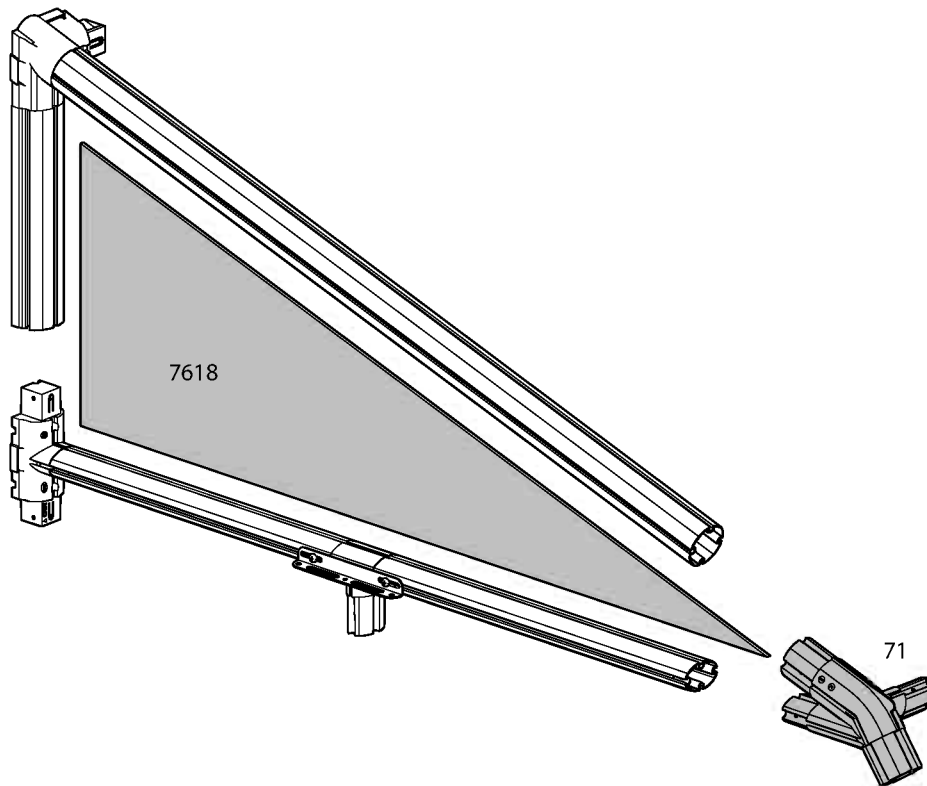
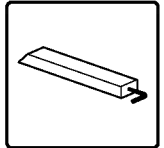

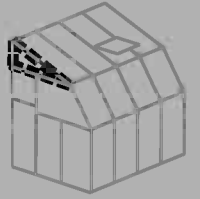

Item		Qty.
pin1		9

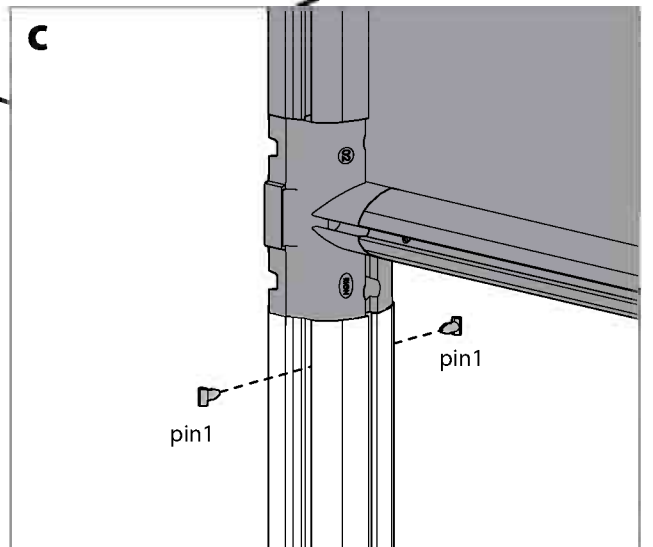
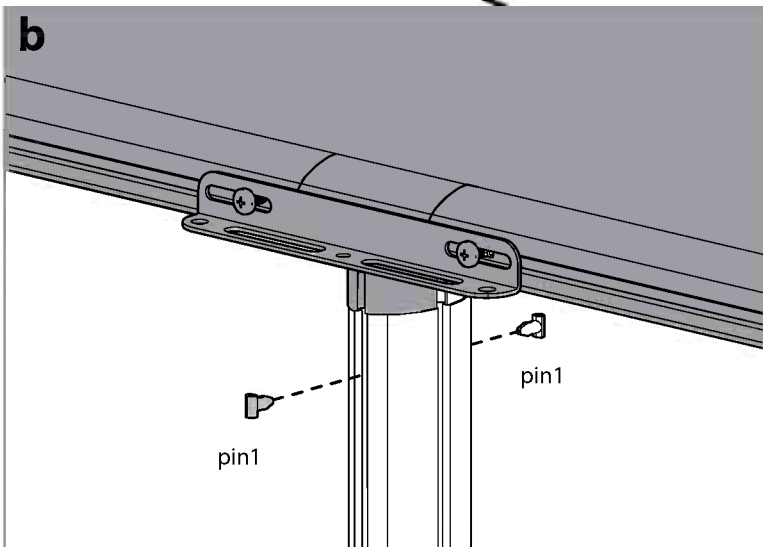
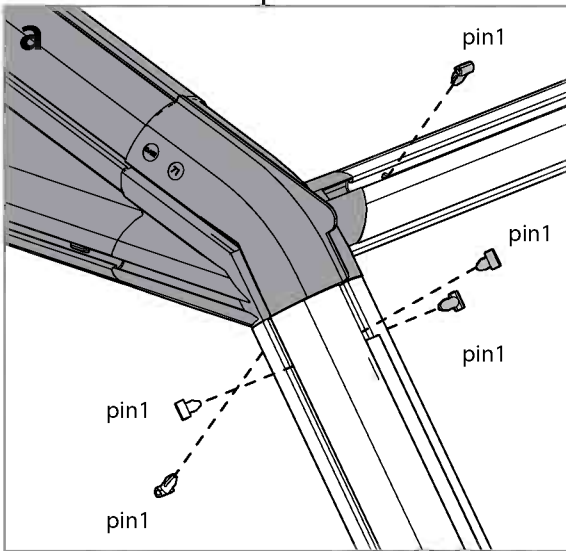
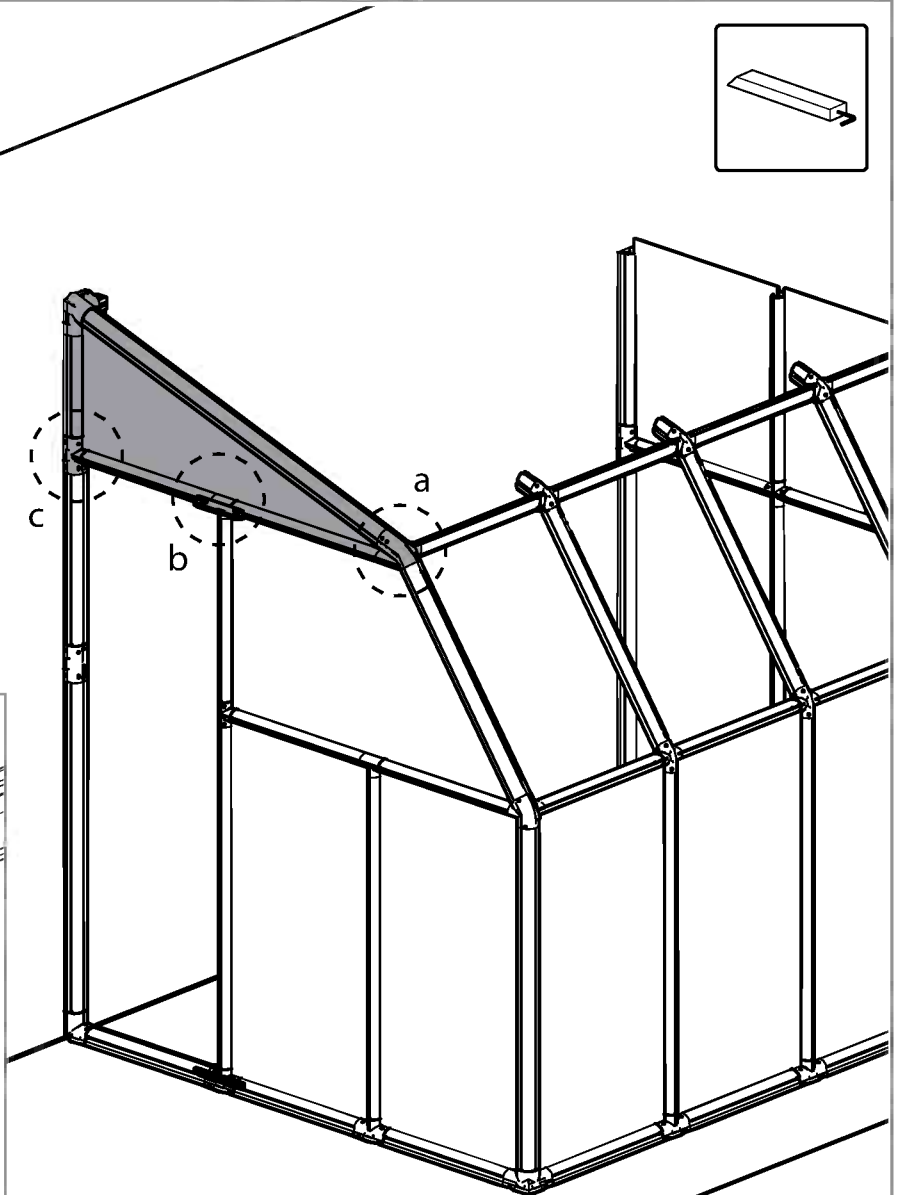
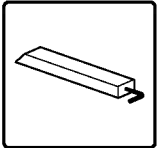

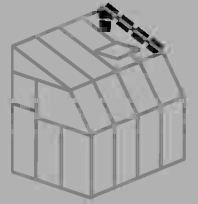



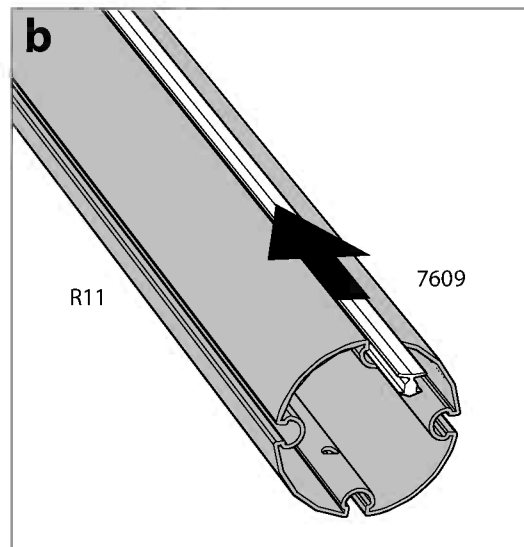
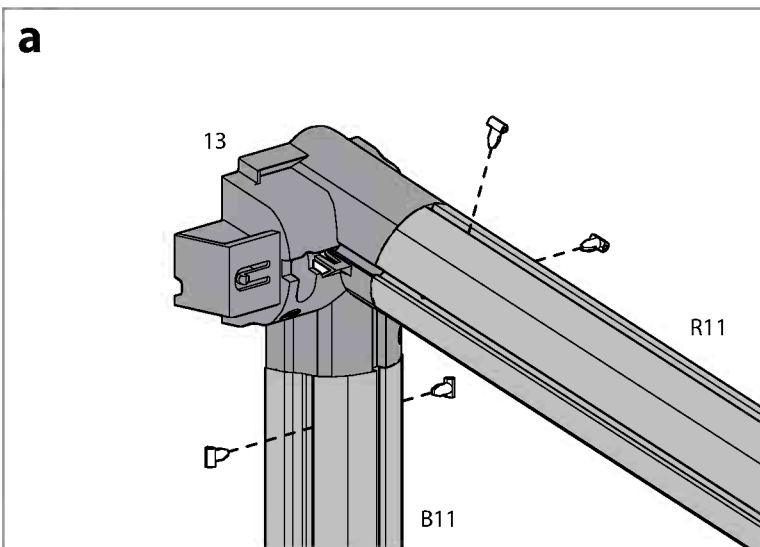
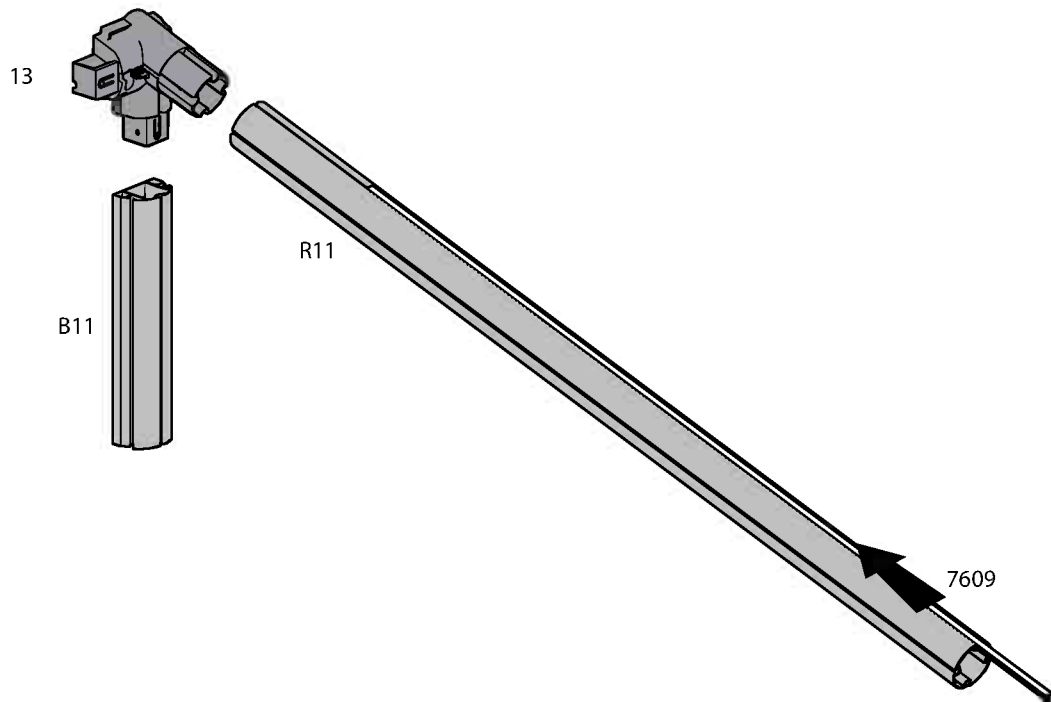
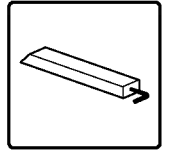

Item		Qty.
R11		1
B11		1
7609		1

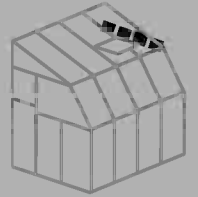
Item		Qty.
13		1
pin1		5





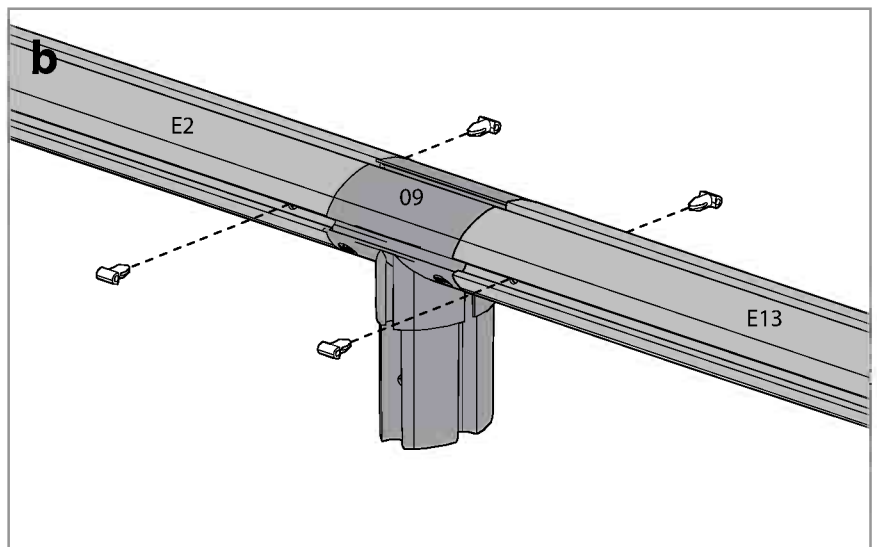
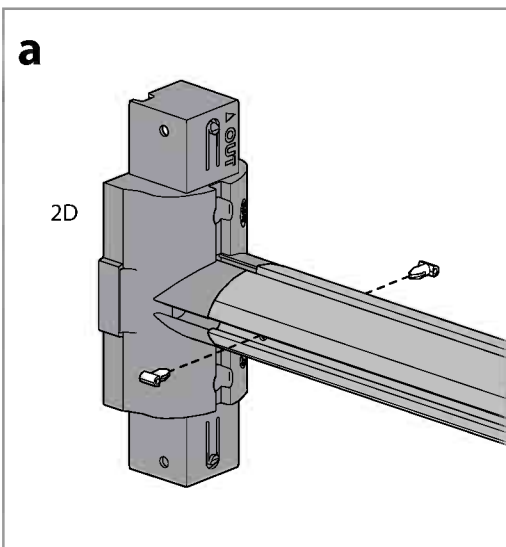
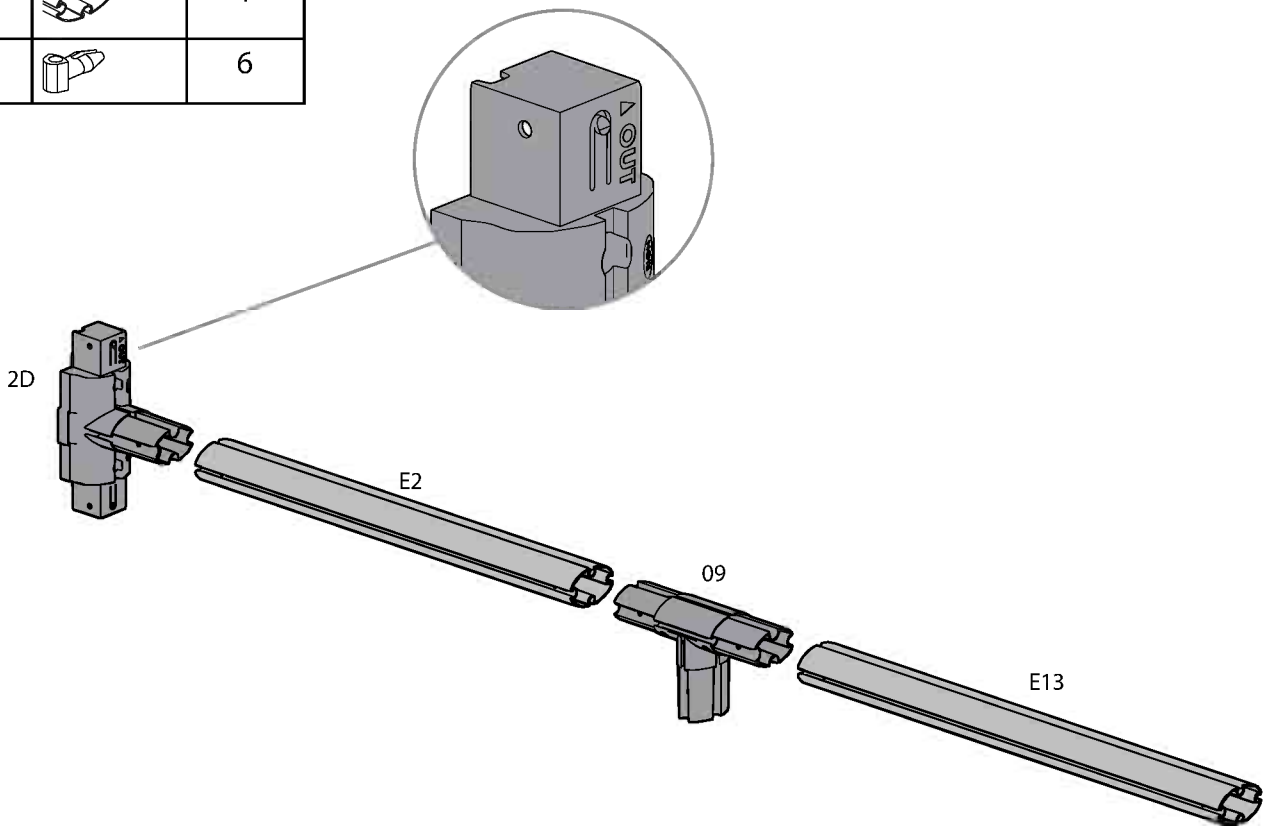
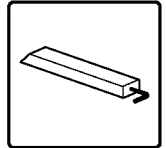

Item		Qty.
2D		1
09		1
E2		1
E13		1
pin1		6

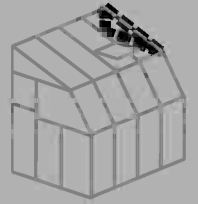

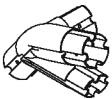
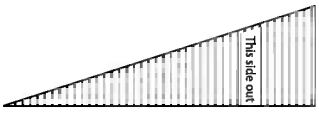

Item		Qty.
76		1
7617		1
pin1		6

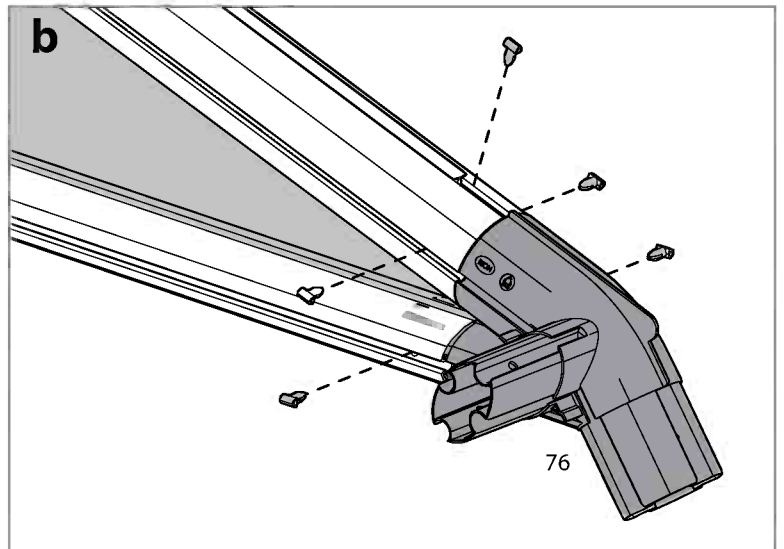
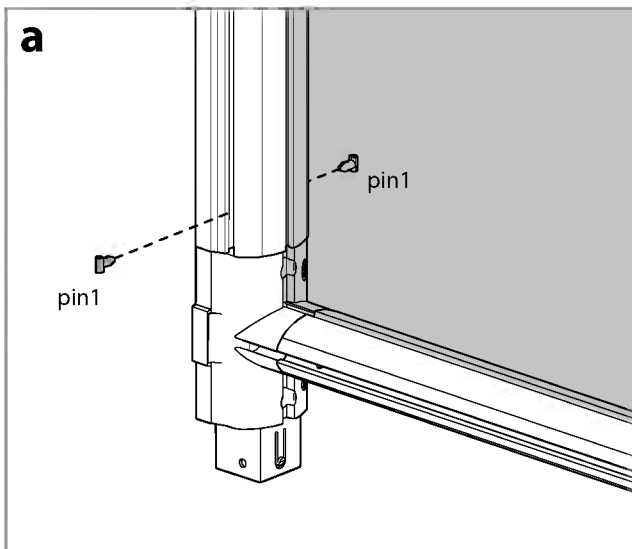
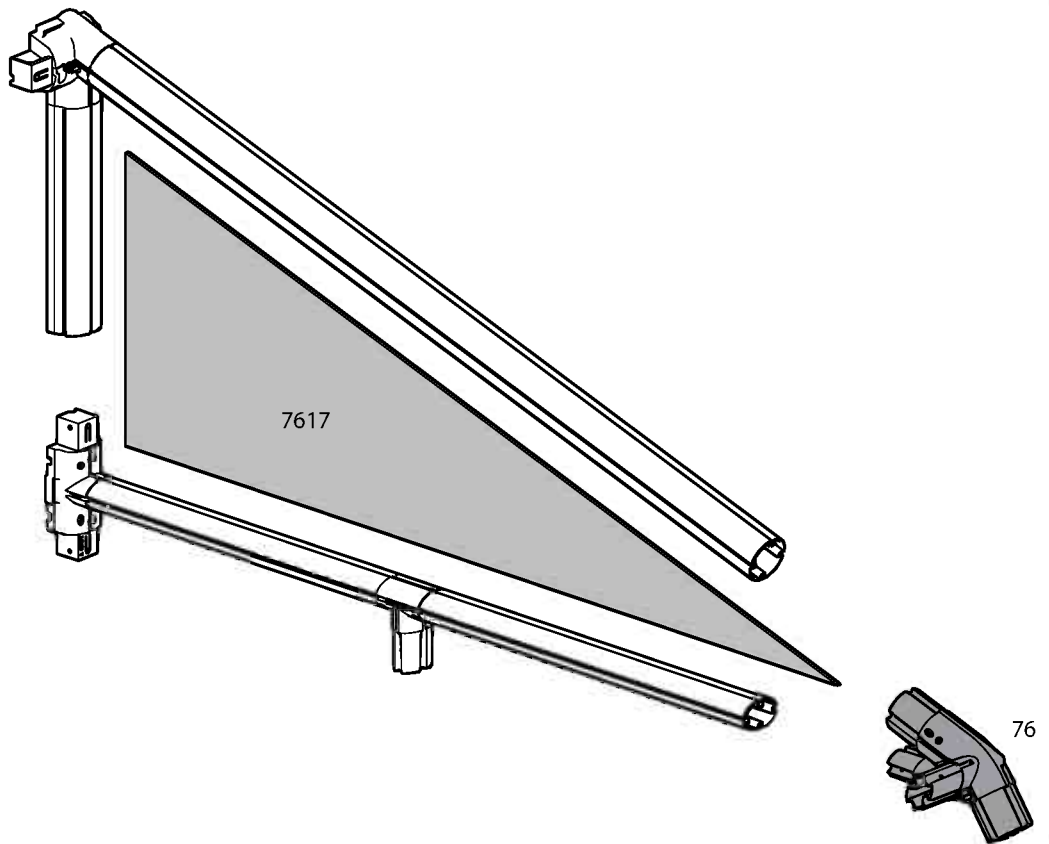
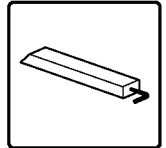

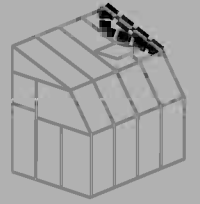

Item		Qty.
pin1		9

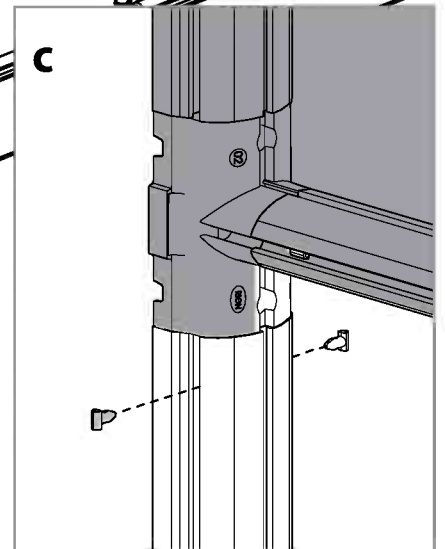
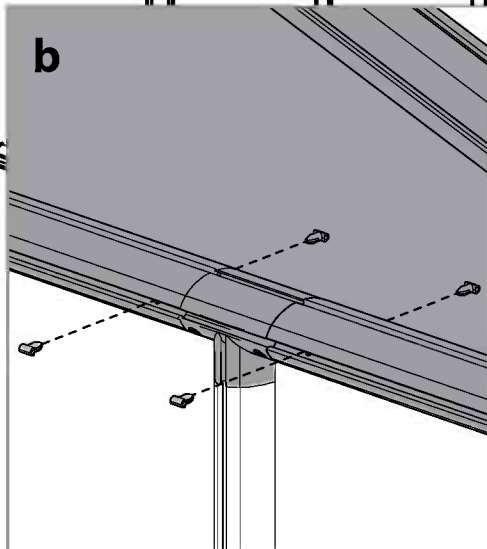
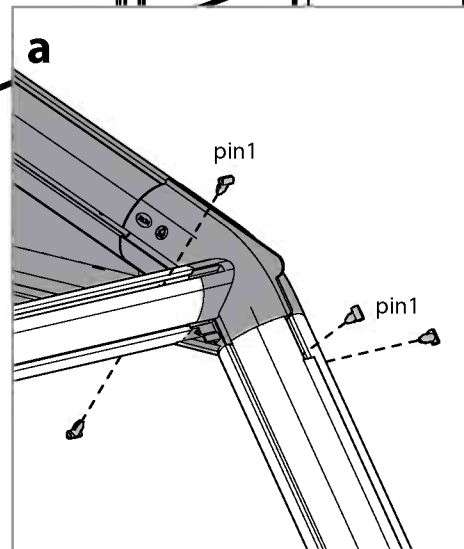
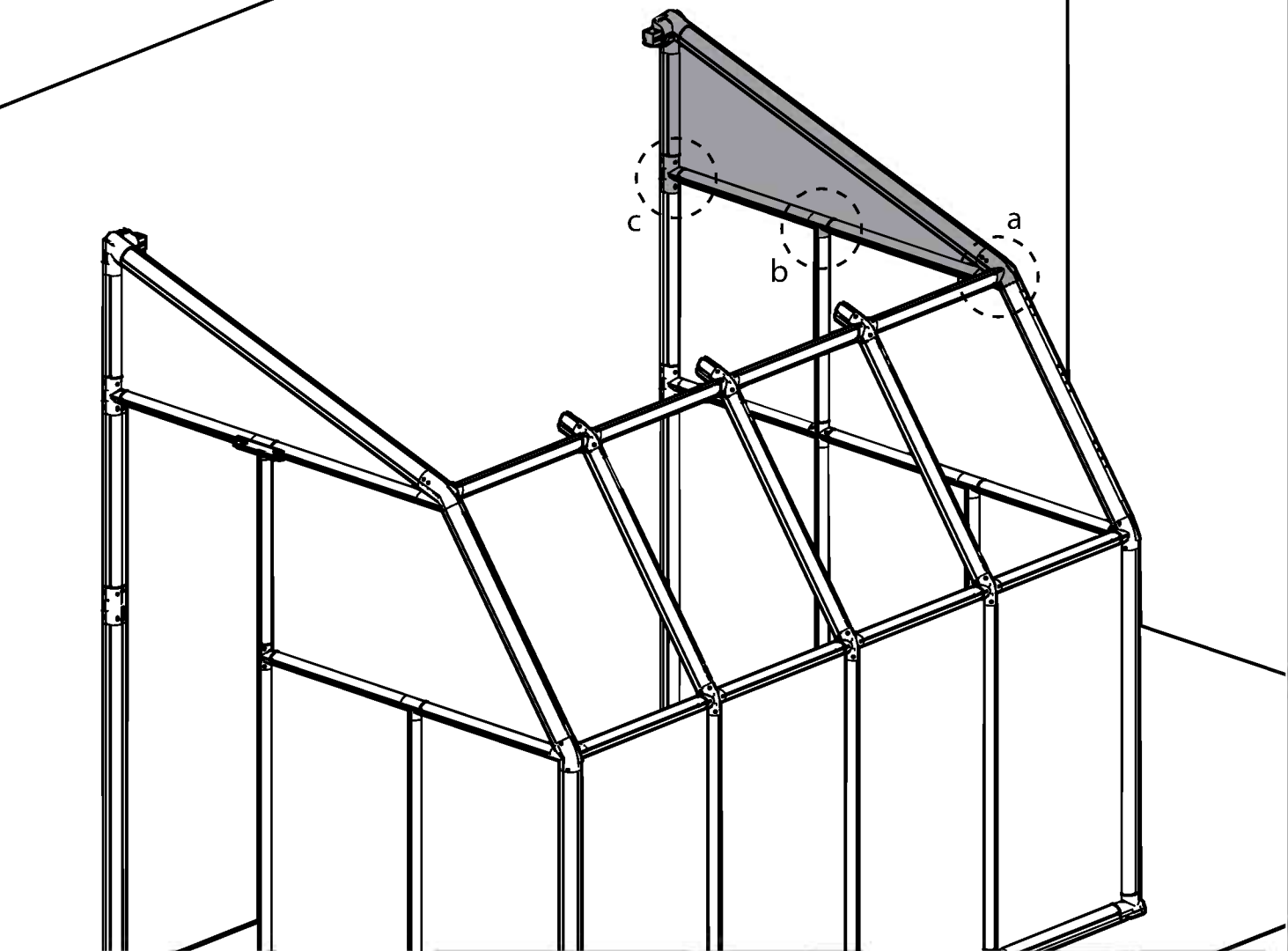
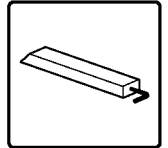

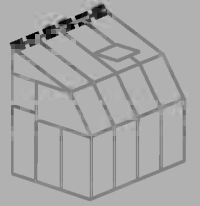

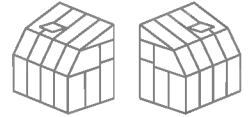
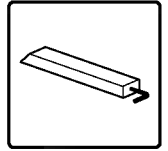

Item		Qty.
B2		4
14		3
pin1		16

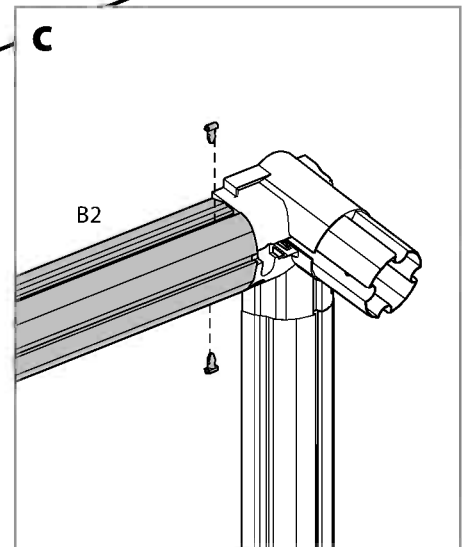
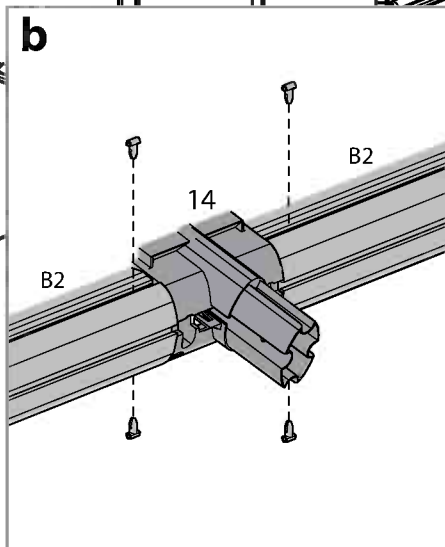
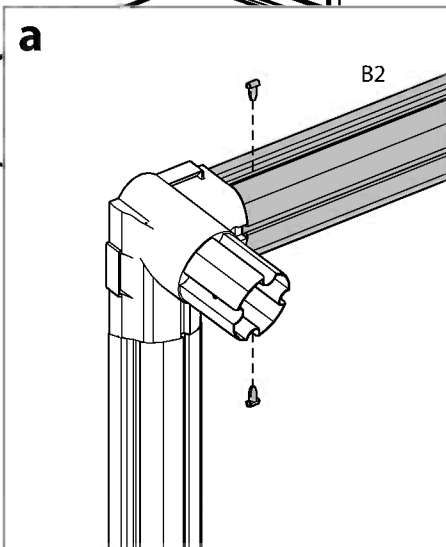
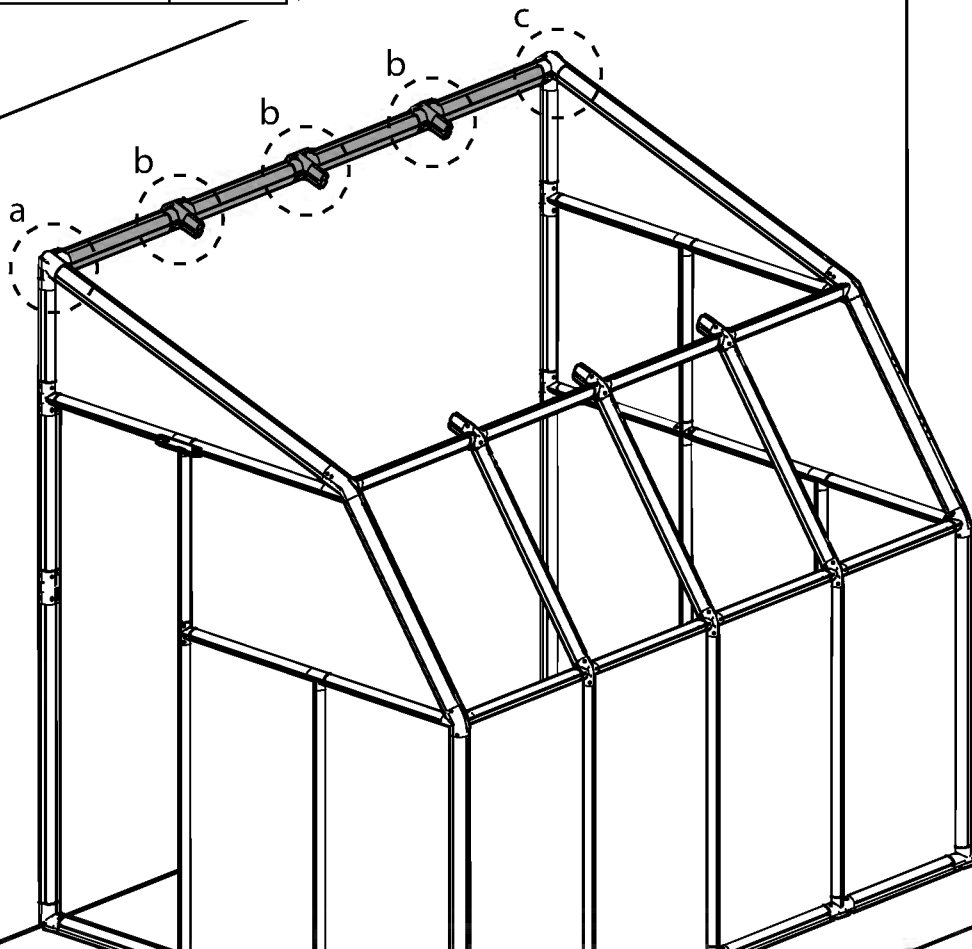

6'x8' = 4xB2
 6'x10' = 5xB2

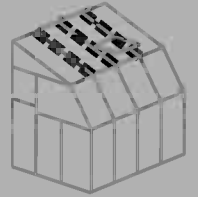

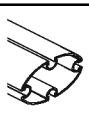

Item		Qty.
E16		3
7610		3
pin1		12

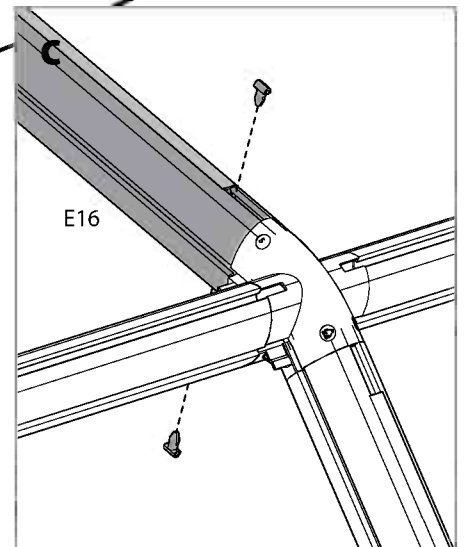
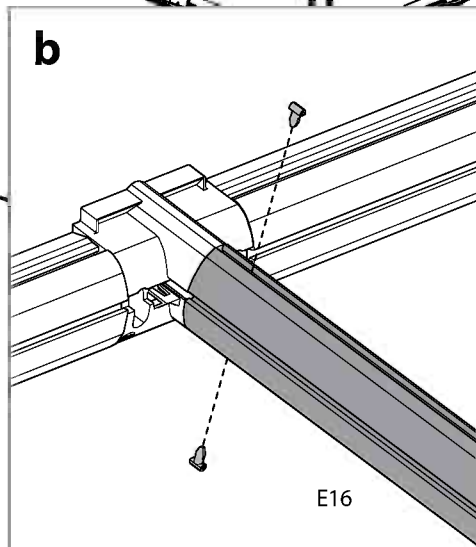
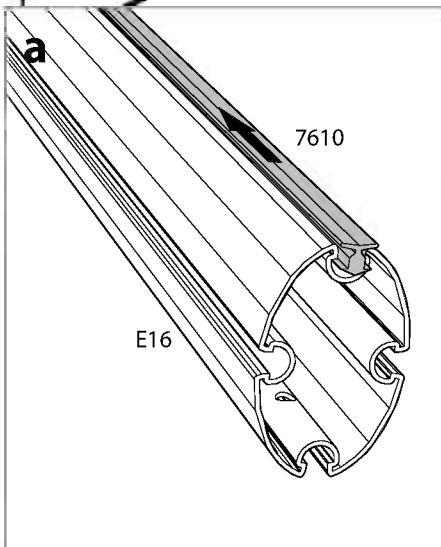
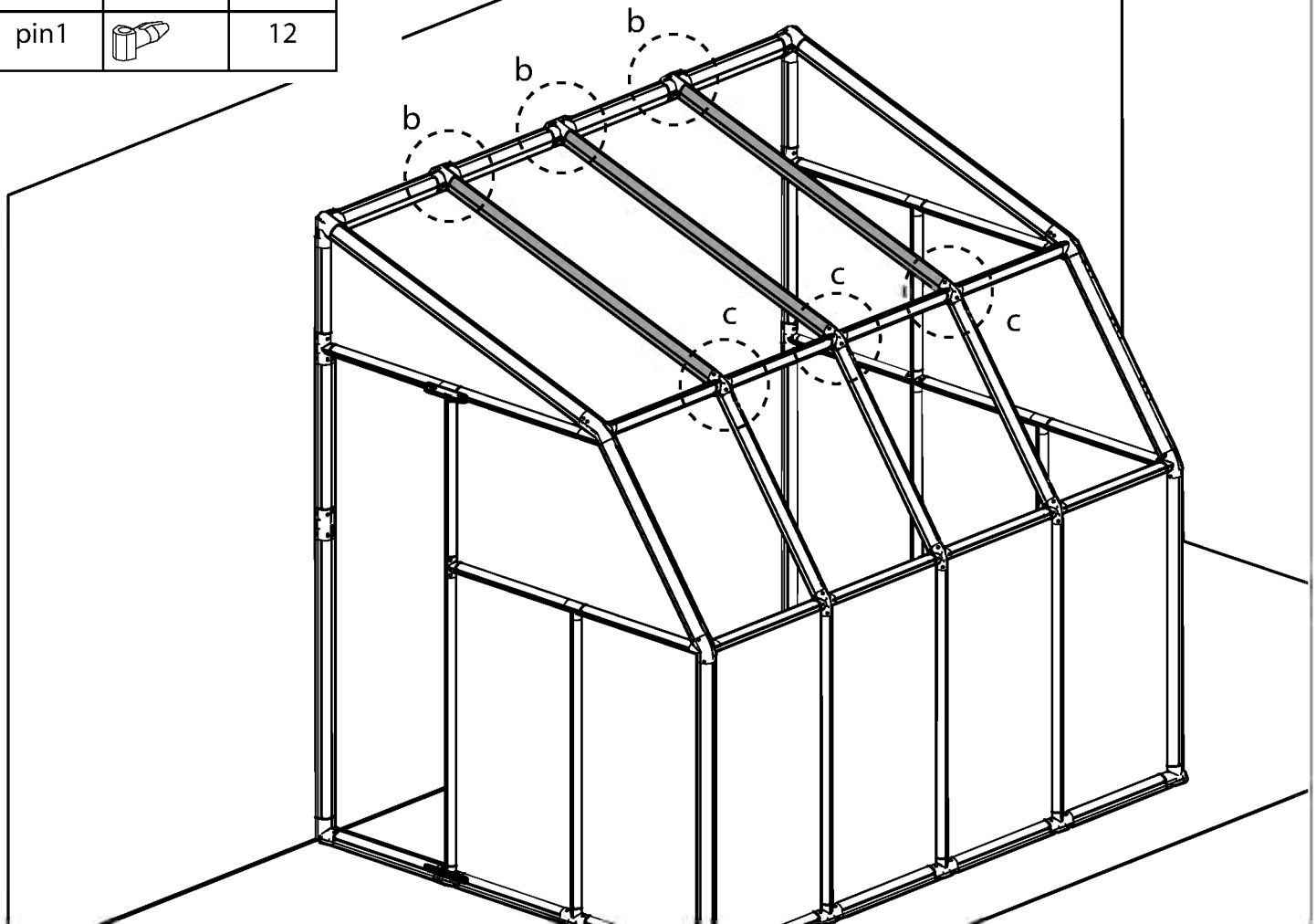
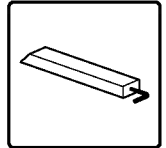

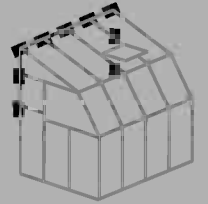

Item		Qty.
BC1		14

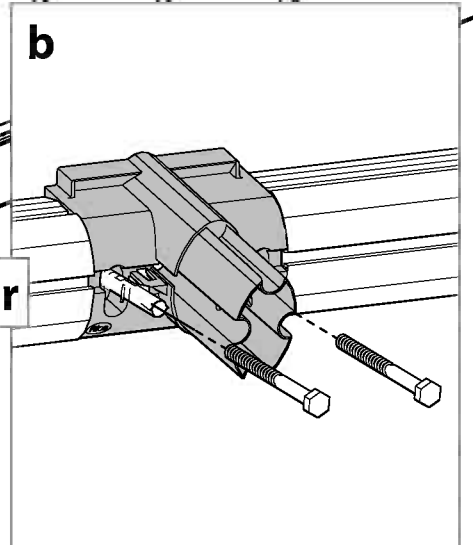
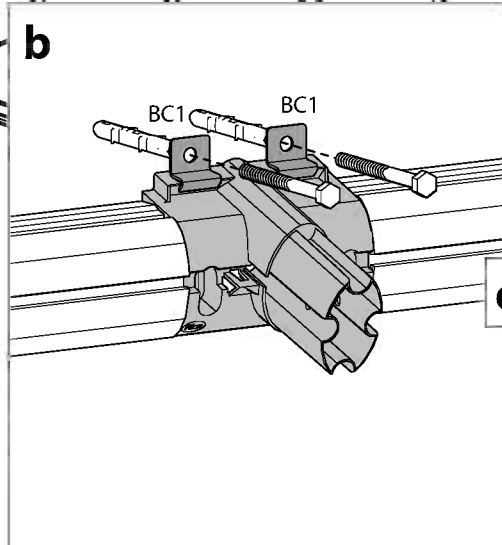
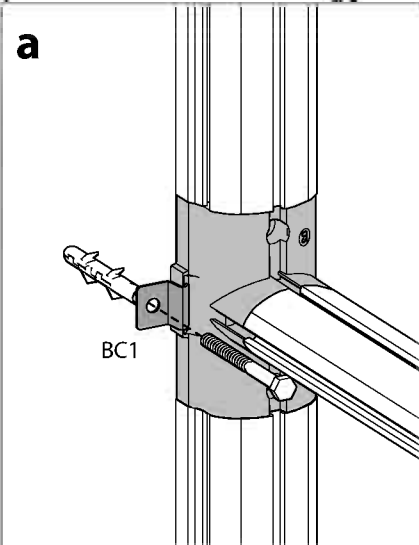
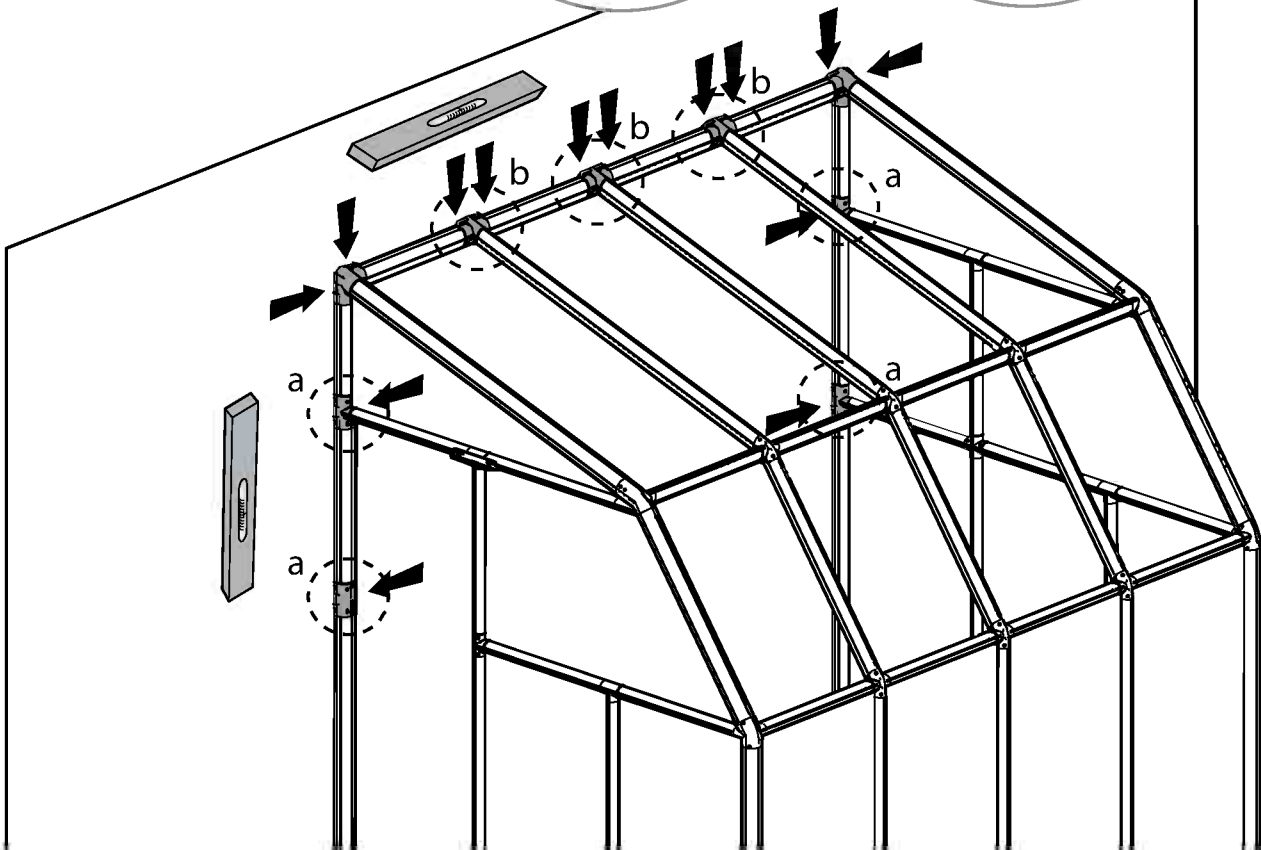
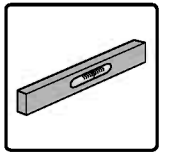
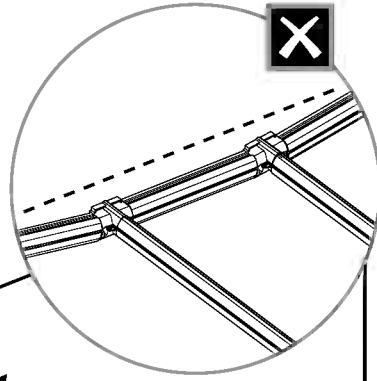
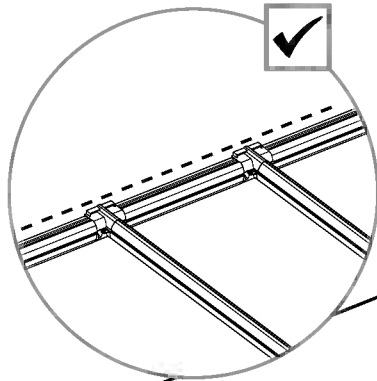

or

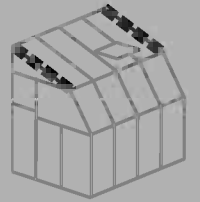

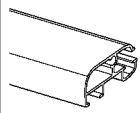
Item		Qty.
7611		2

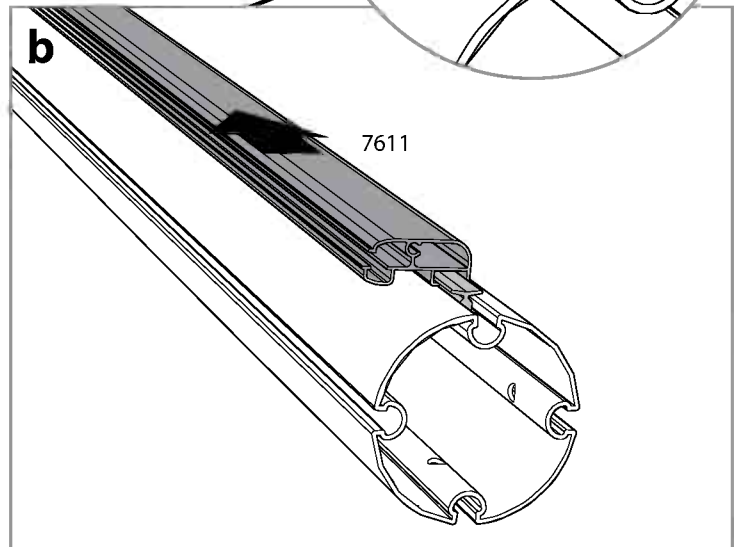
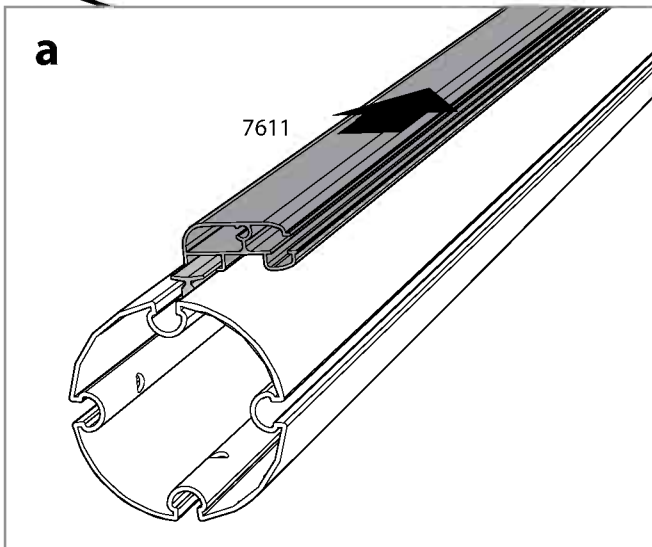
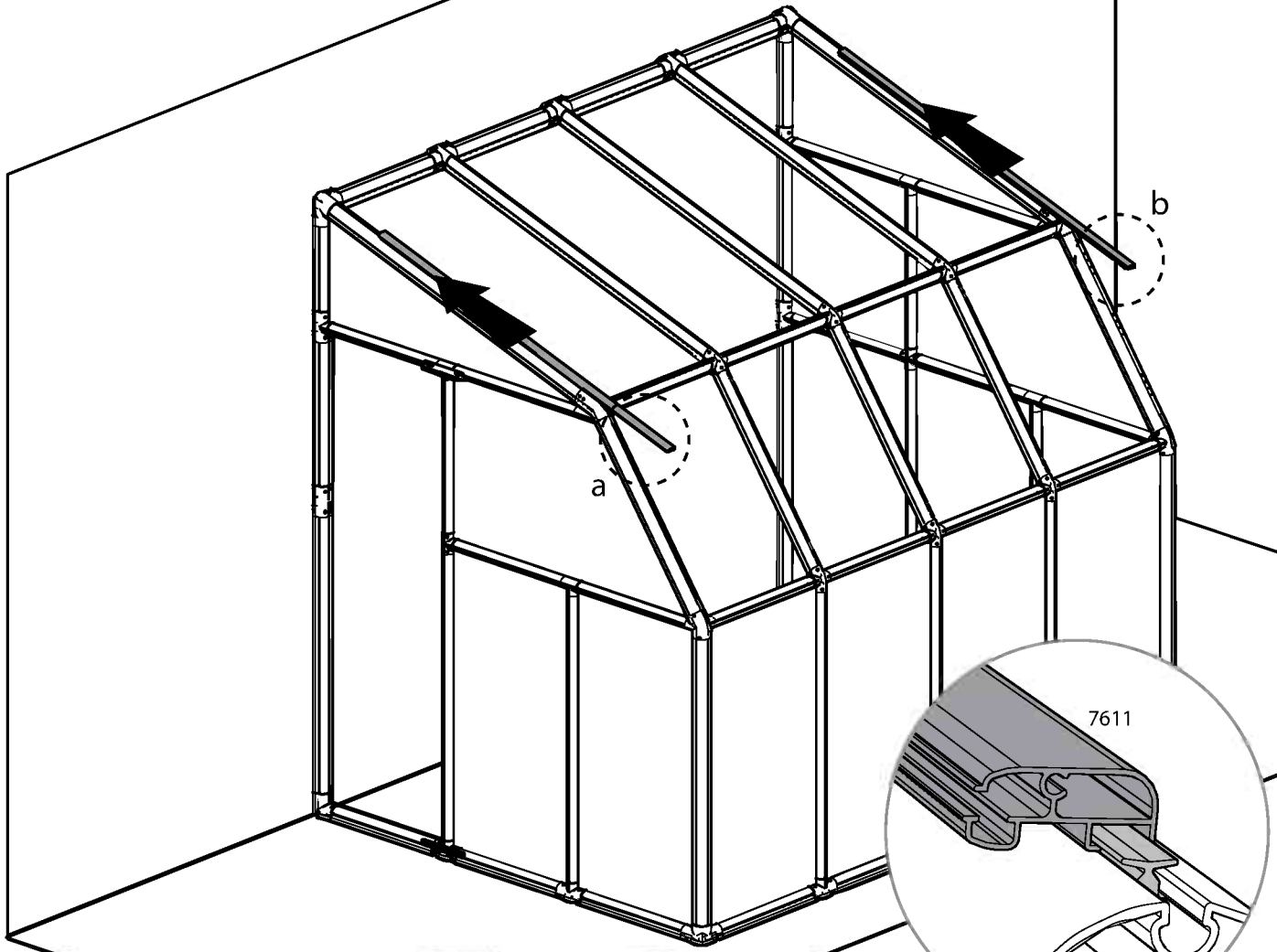

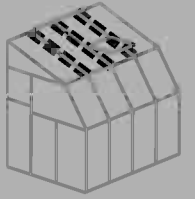

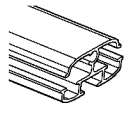
Item		Qty.
7613		3

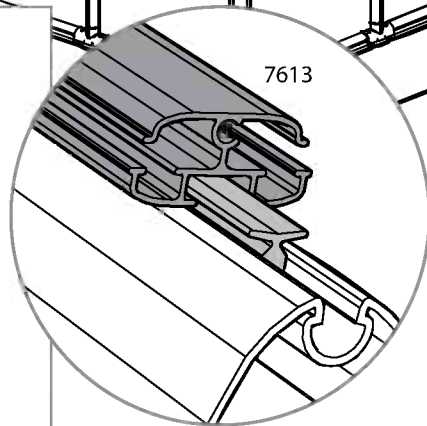
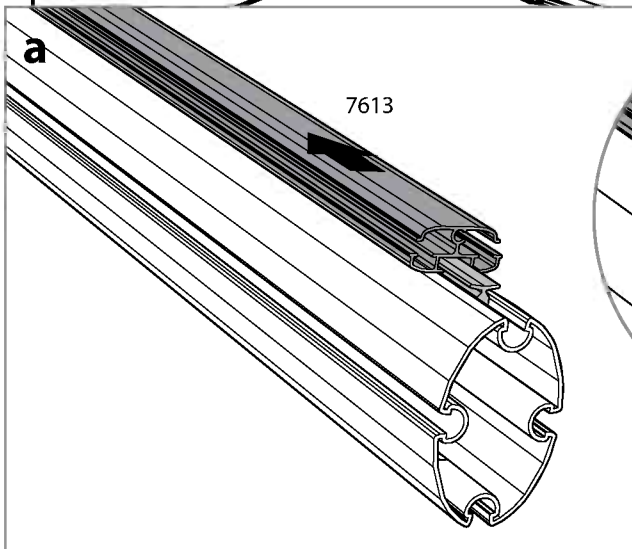
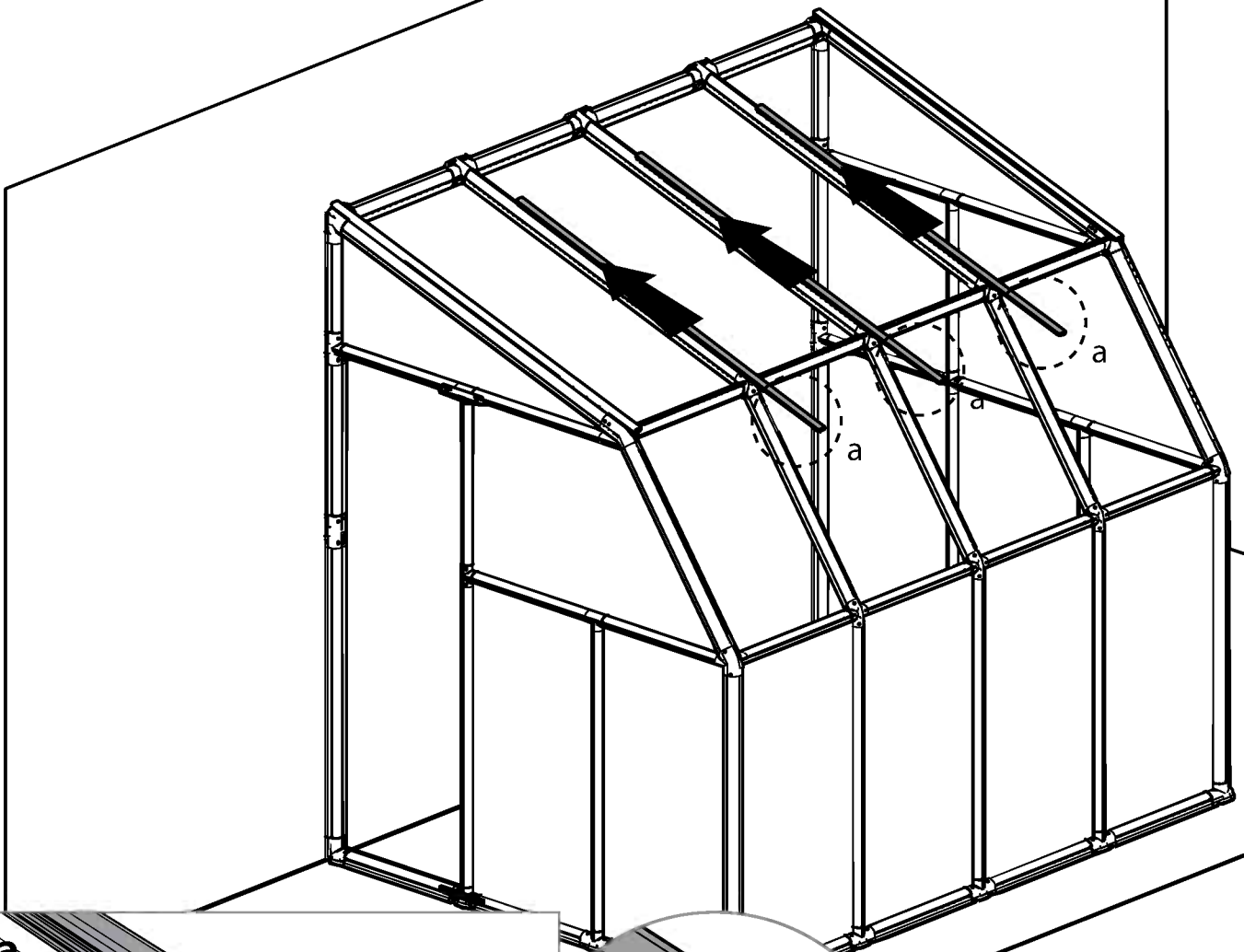

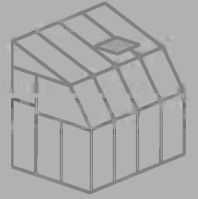



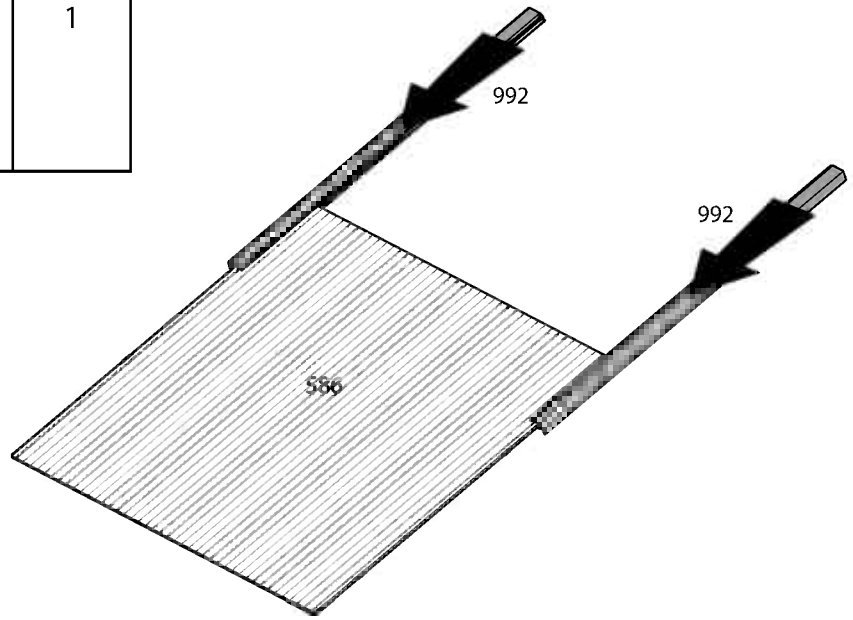
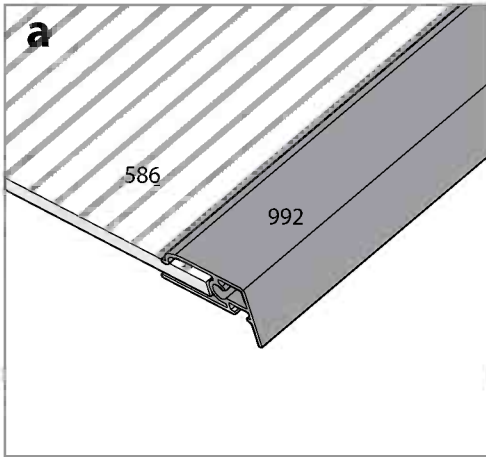

Item		Qty.
992		2
586		1

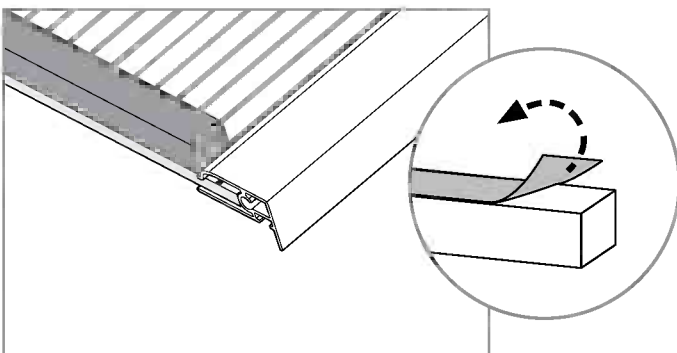
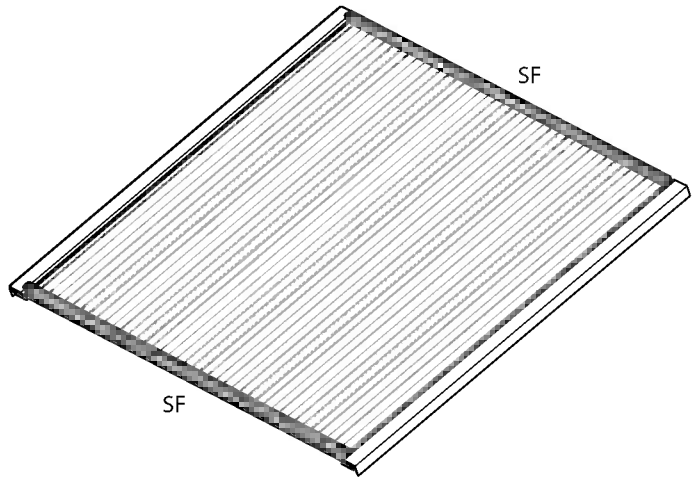
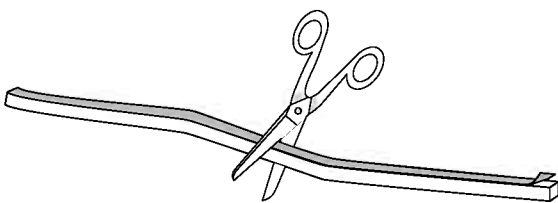
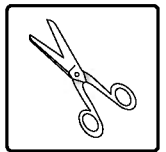

Item		Qty.
SF		1





Item		Qty.
989		1
991		1
4008		4
411		2

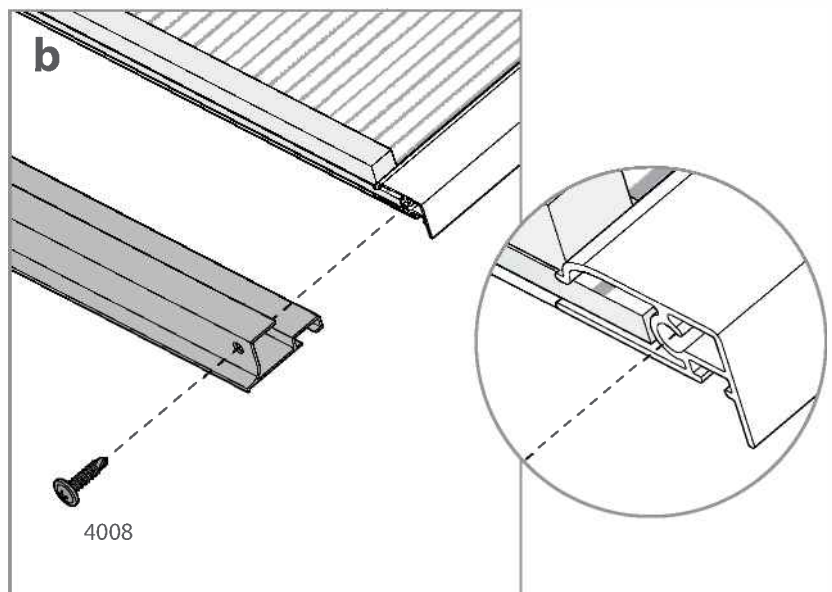
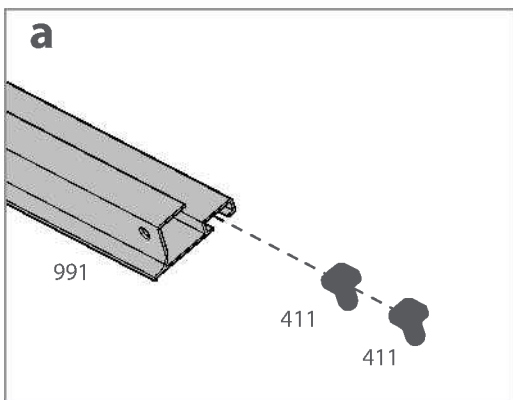
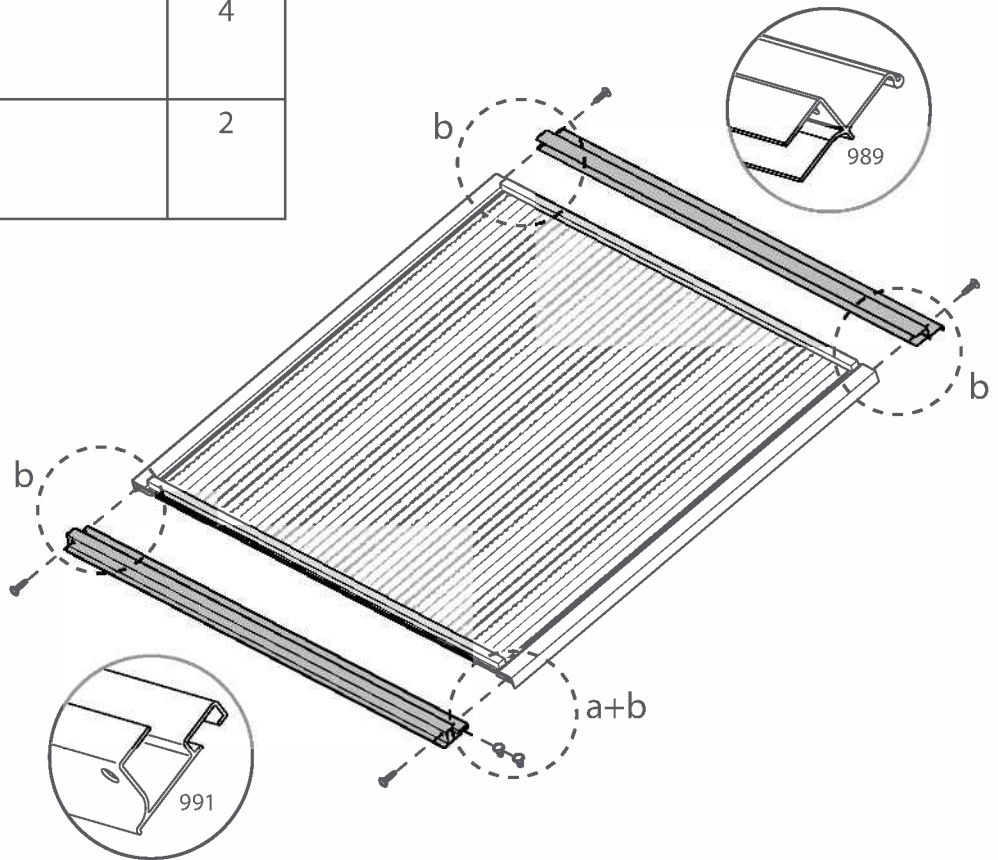



Item		Qty.
7536		1
7533		1
7534		1
465	M4x8mm	2
422	M4	2

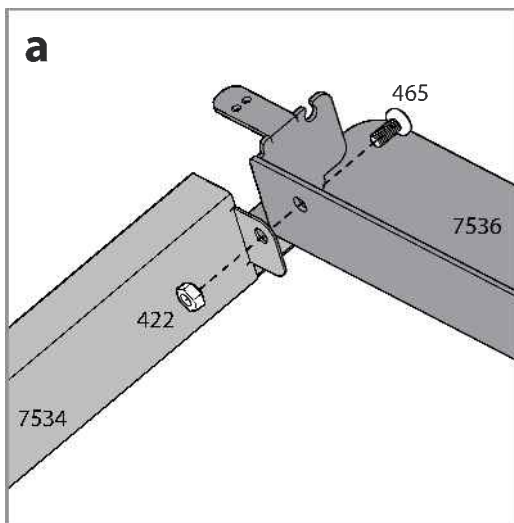
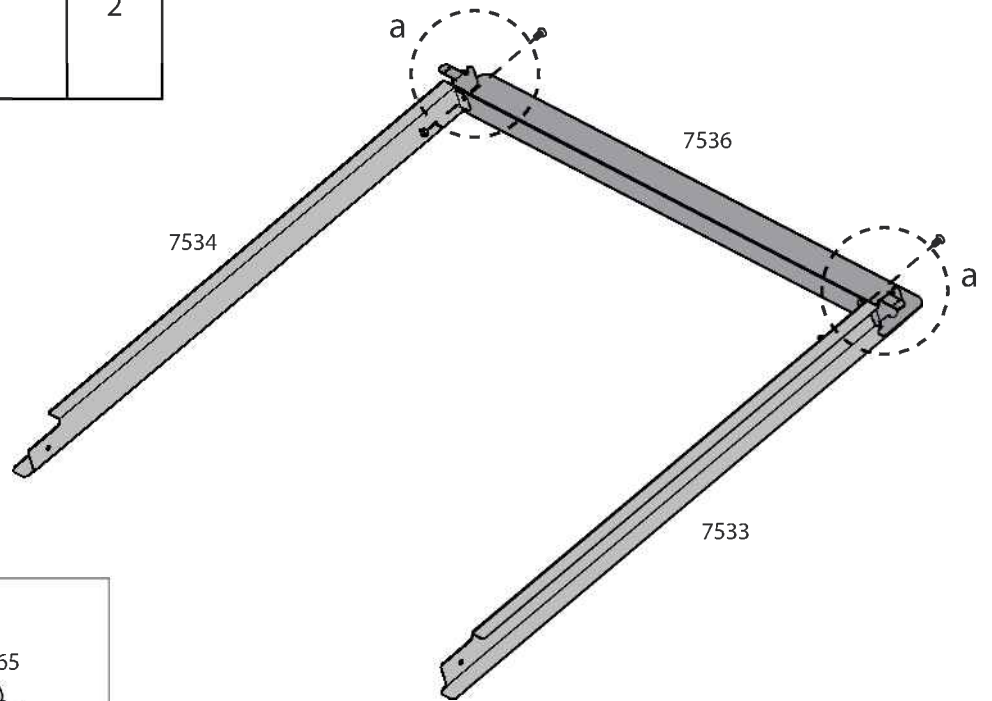
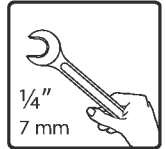
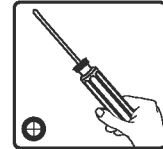

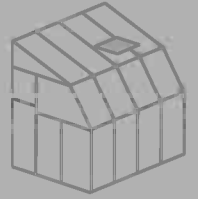

Item		Qty.
7535		1
465	M4x8mm	2
422	M4	2

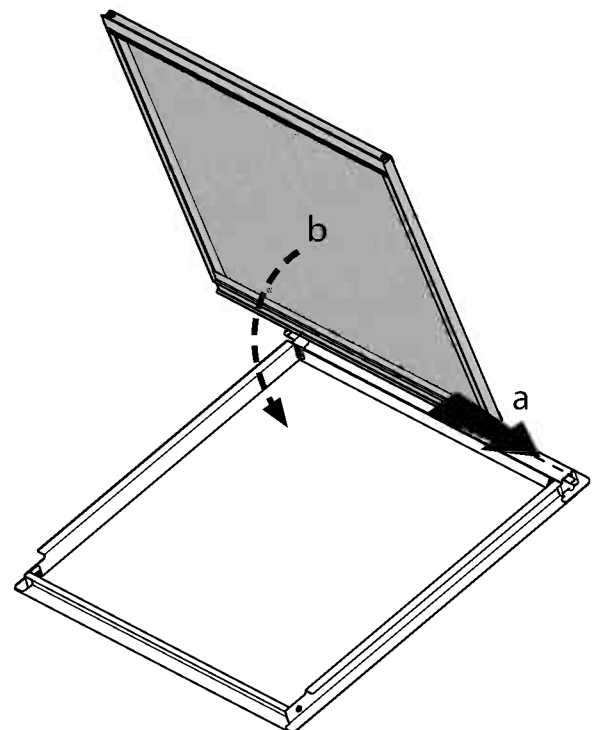
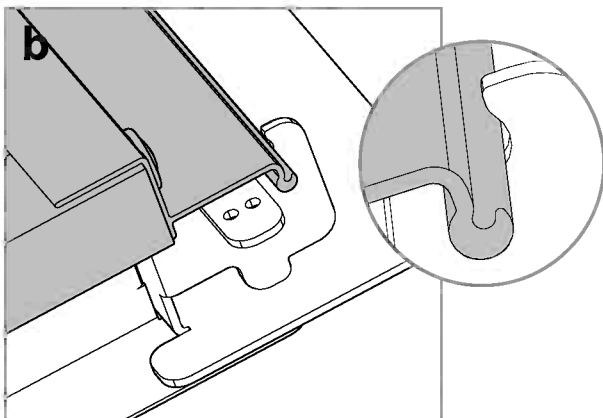
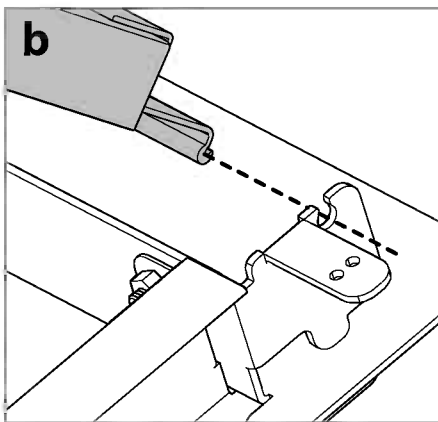
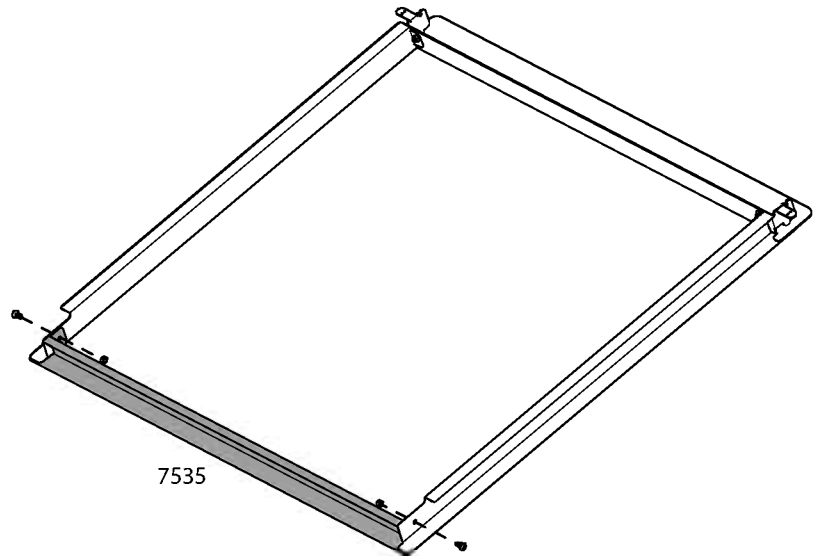
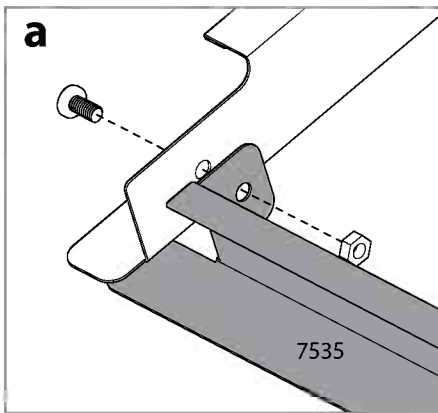
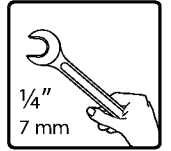
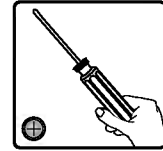

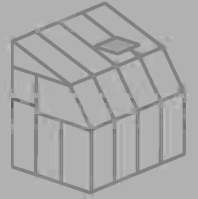

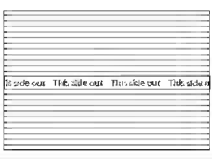
Item		Qty.
7630		1

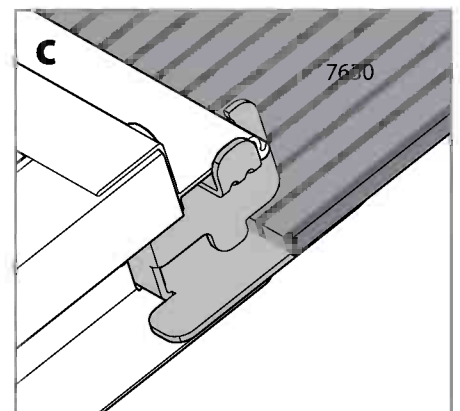
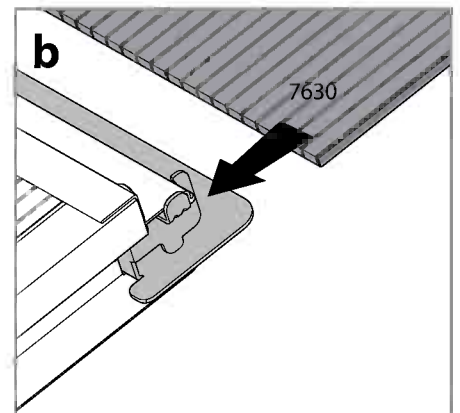
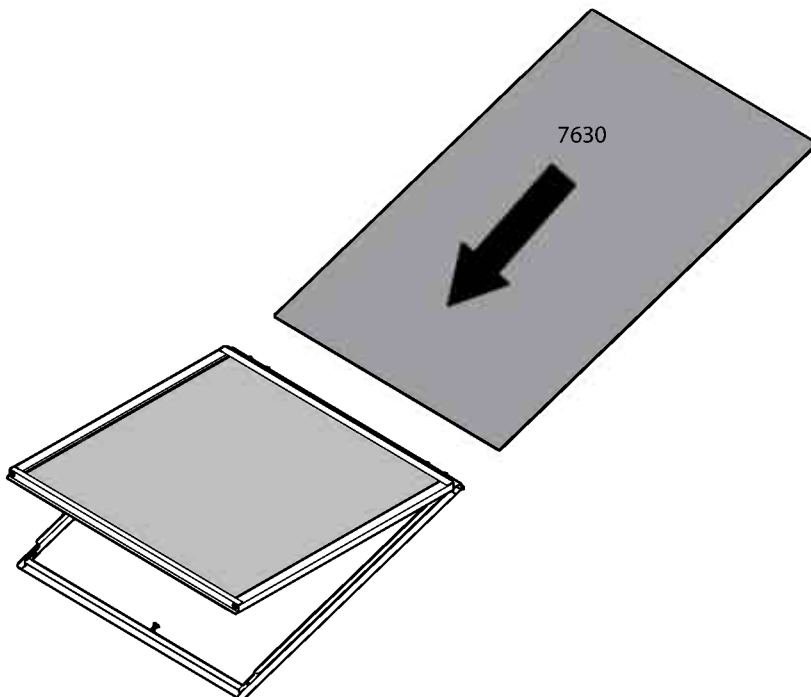
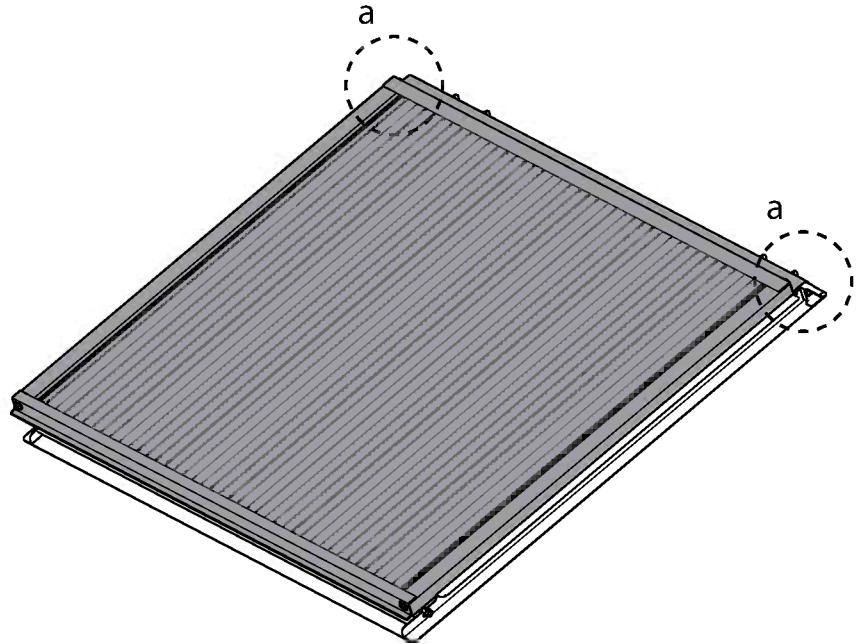
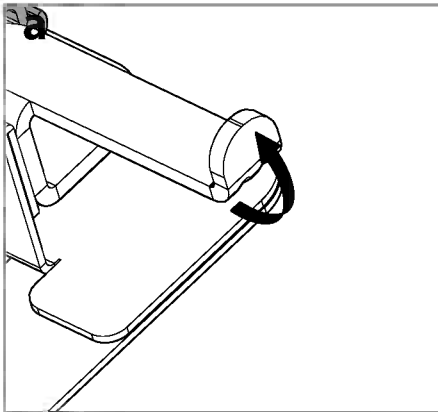
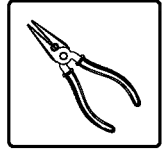

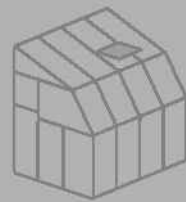

- EN** Windows Location
- DE** Fenster Standort
- FR** Fenêtre Emplacement
- ES** Ventana Ubicación

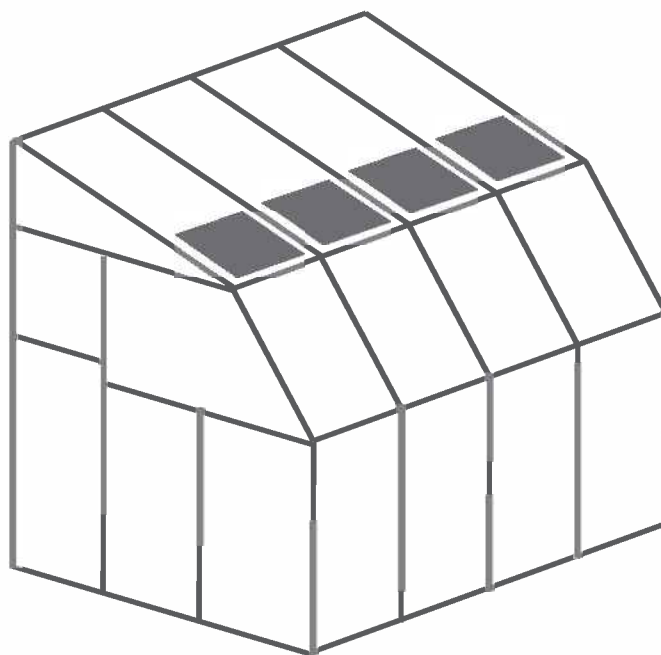
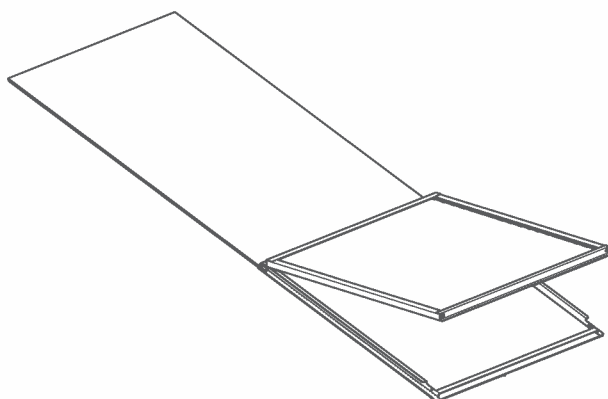

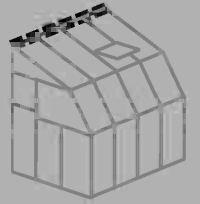

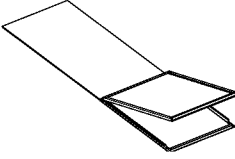
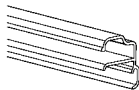
Item		Qty.
PN57		3
Window		1
981		4

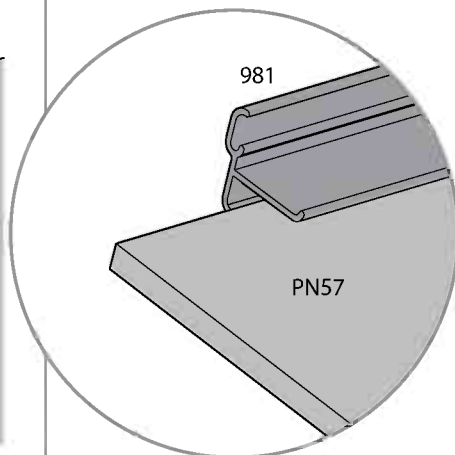
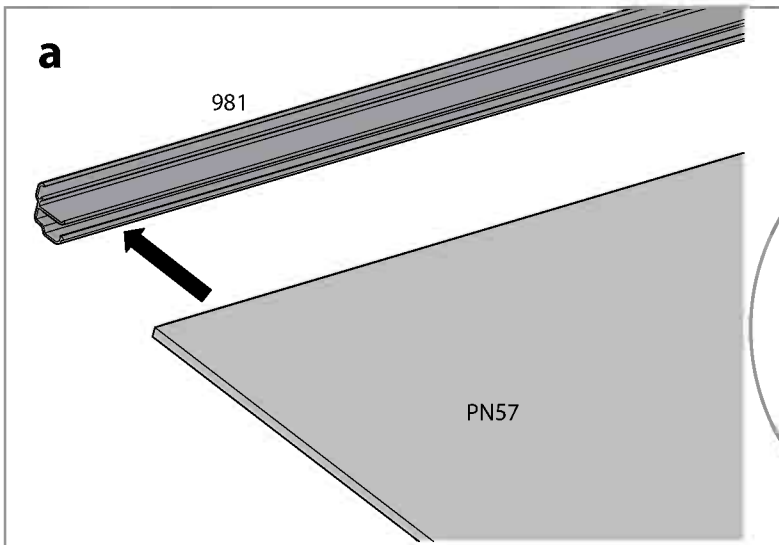
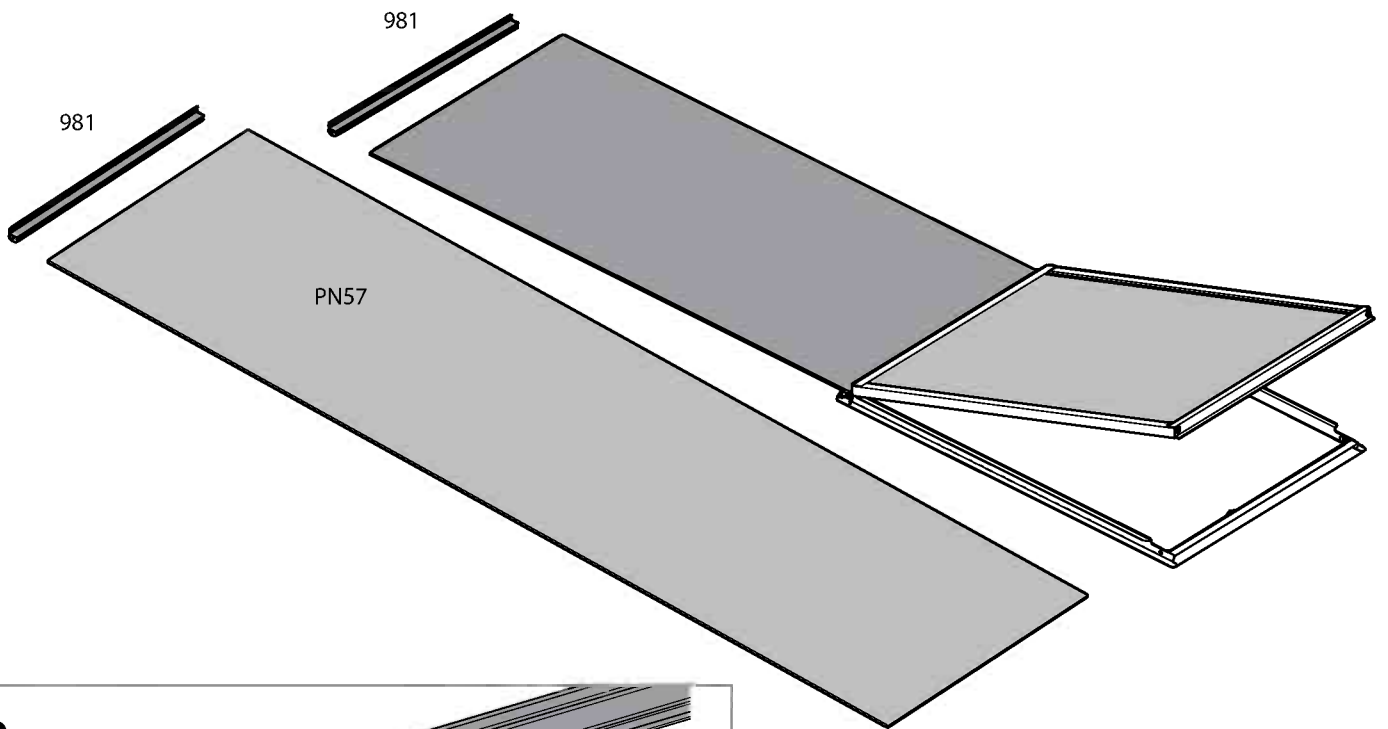

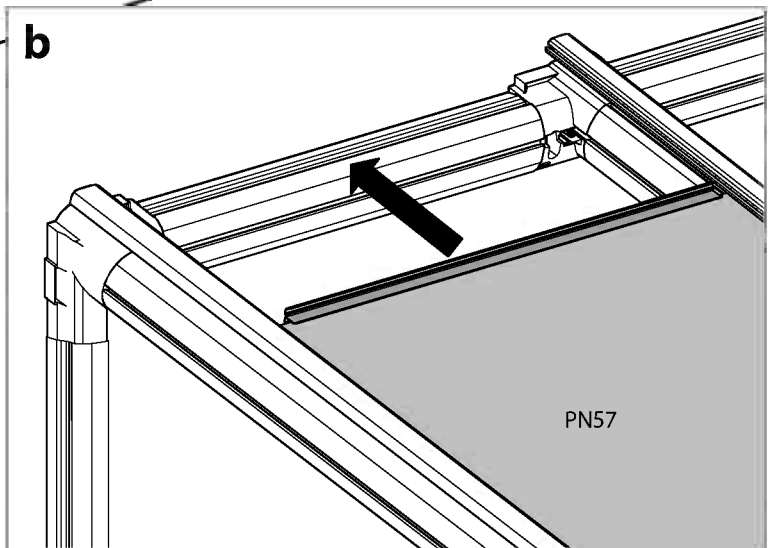
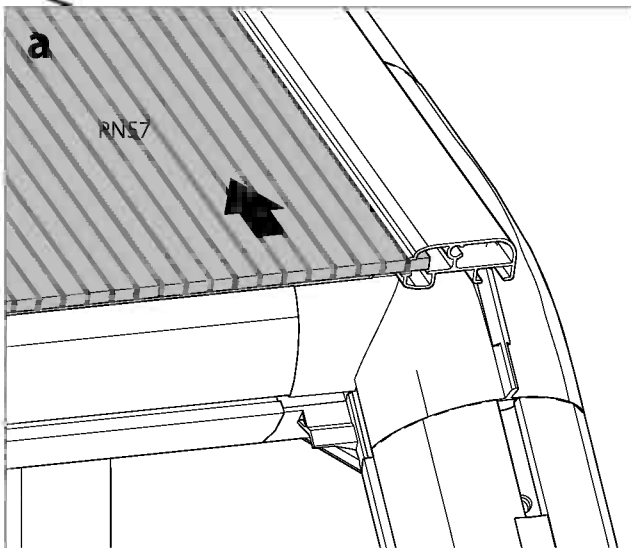
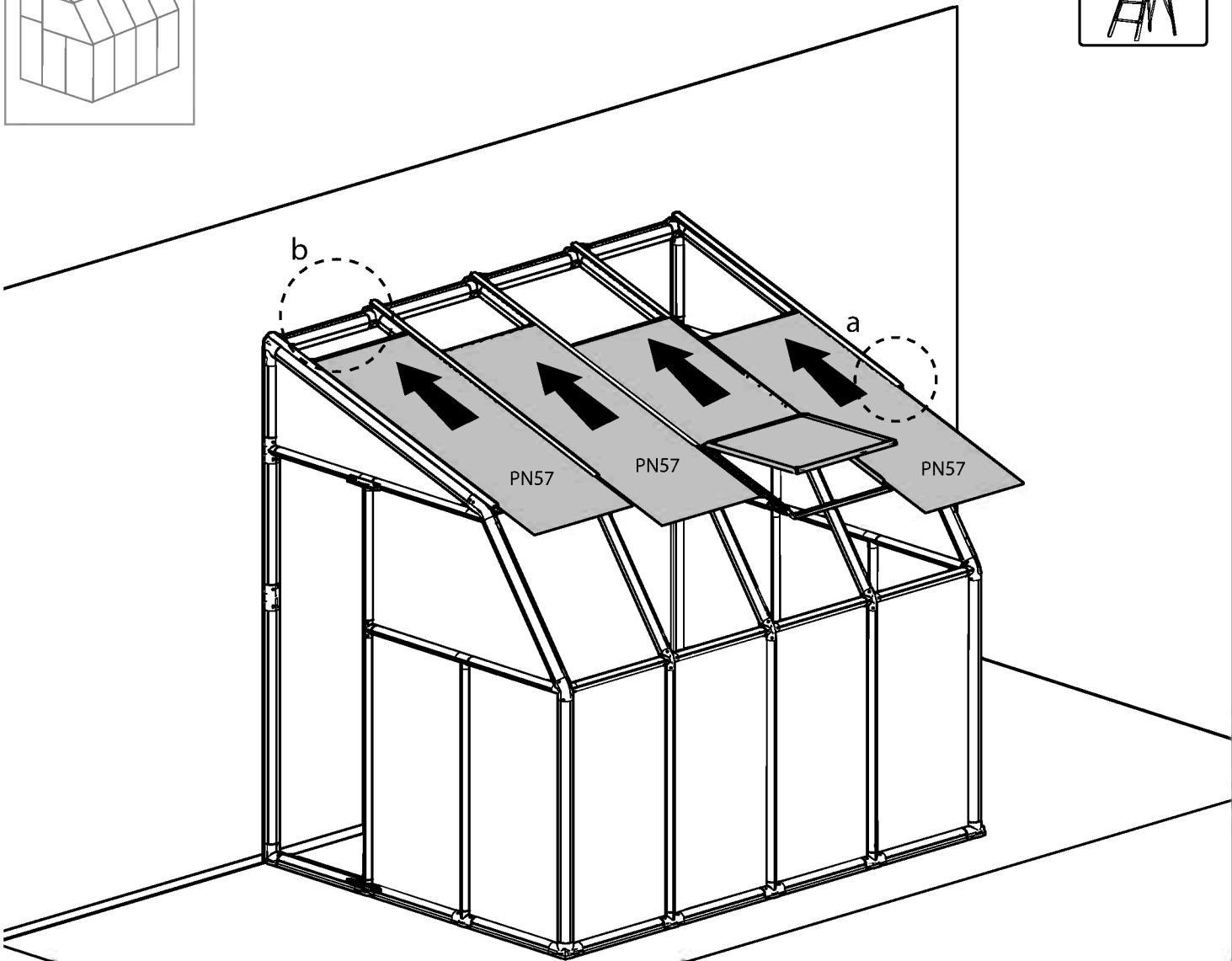
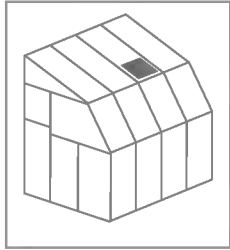
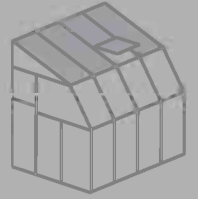

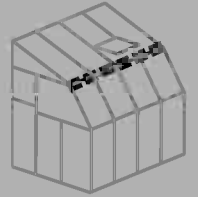



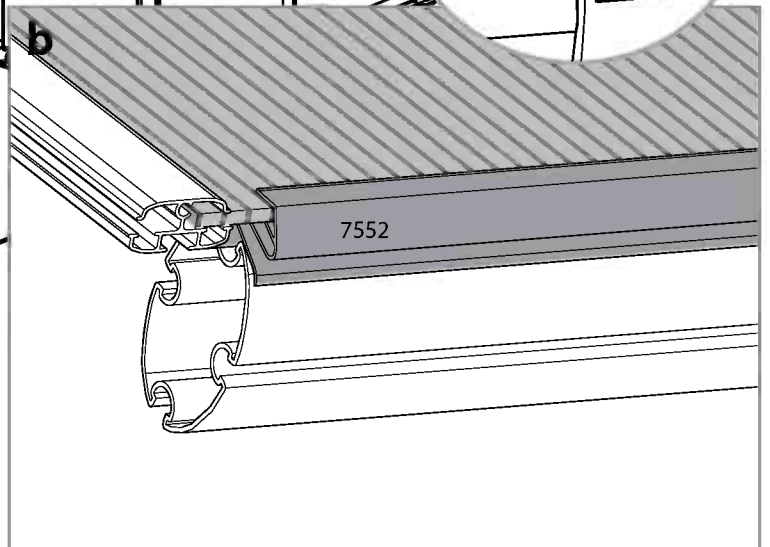
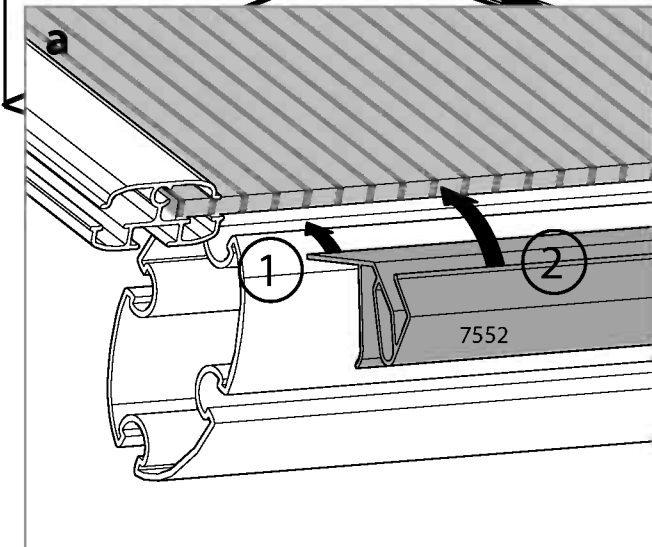
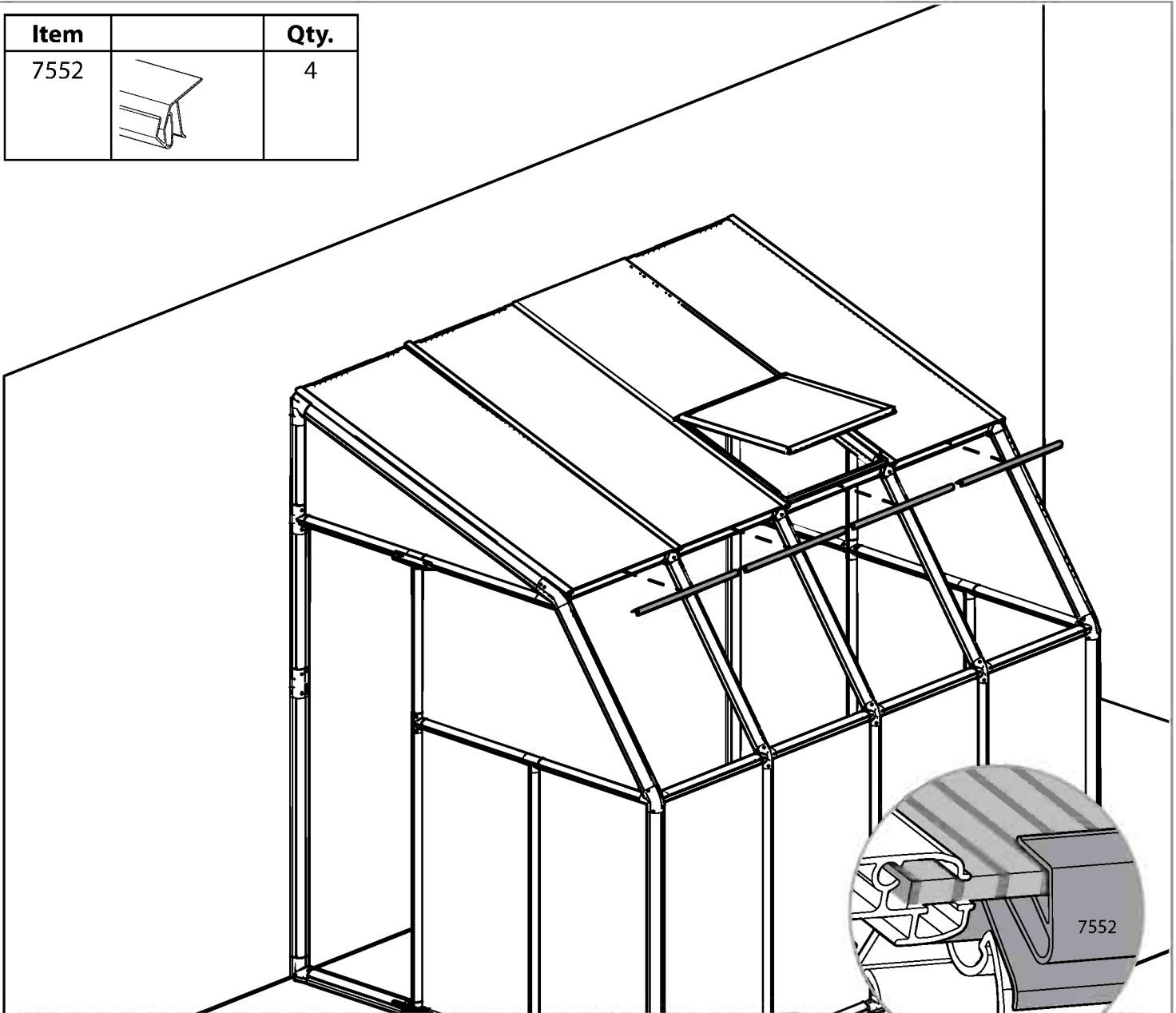

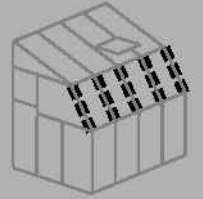

Item		Qty.
7552		4



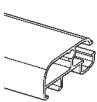

Item		Qty.
72		1
73		1
74		3
7612		2
7614		3
4043		5

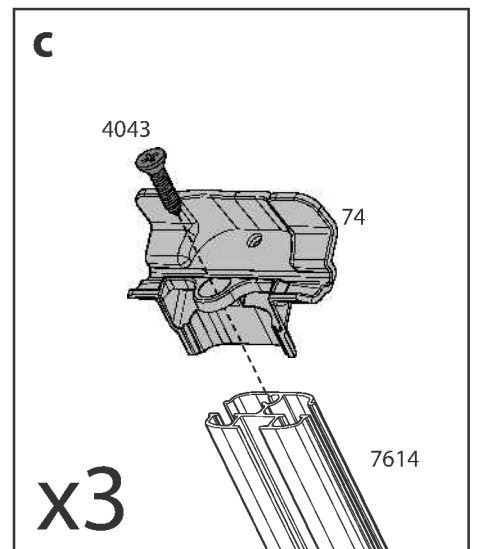
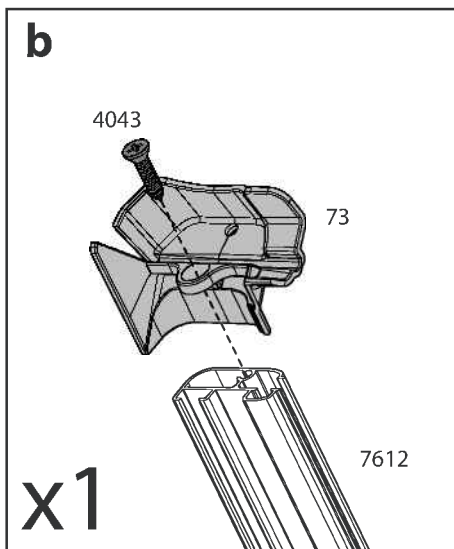
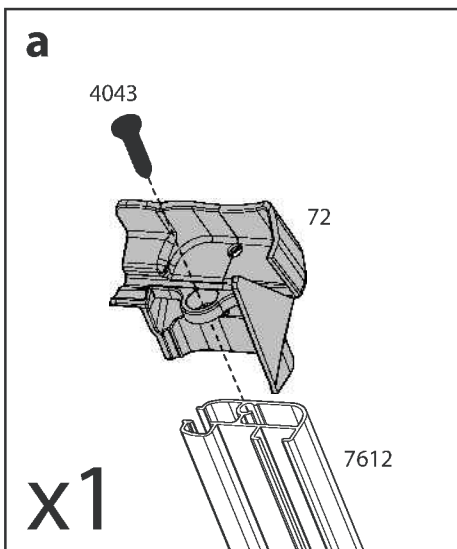
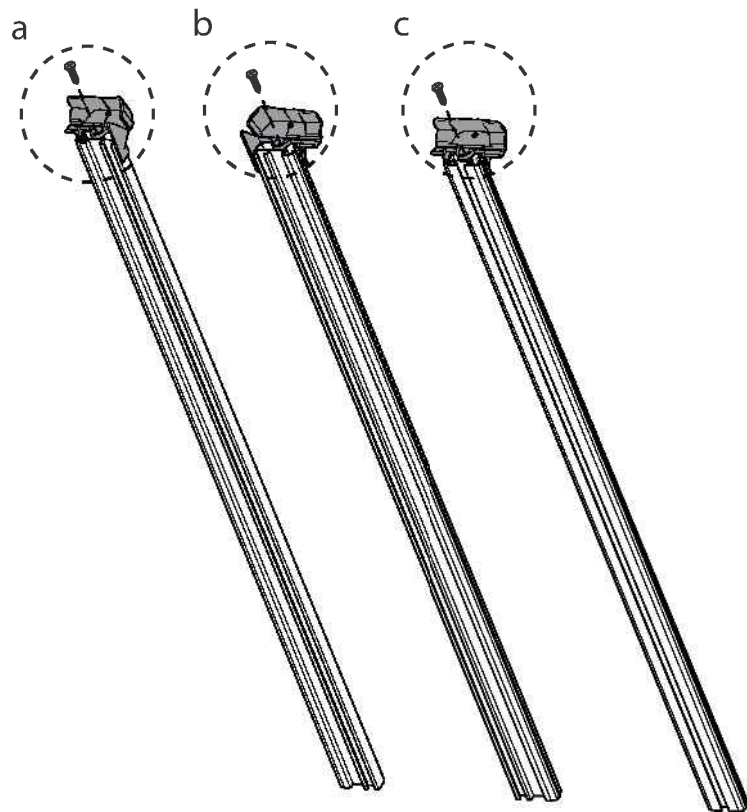
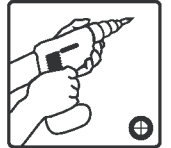

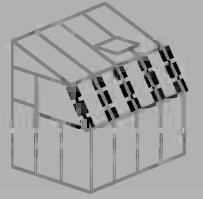

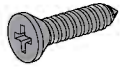

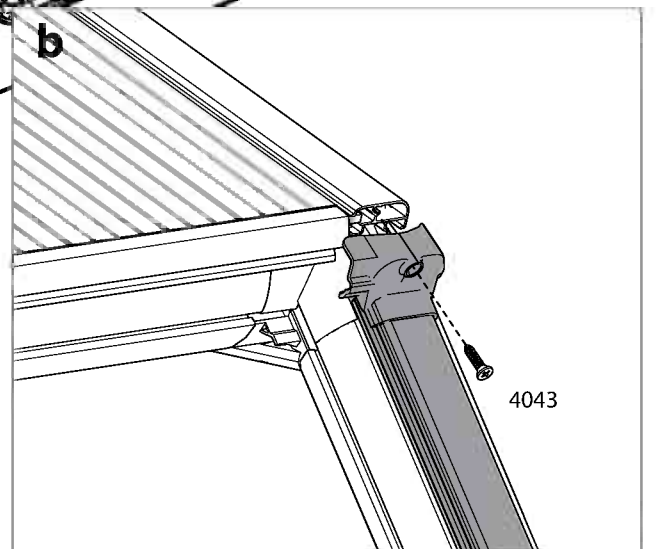
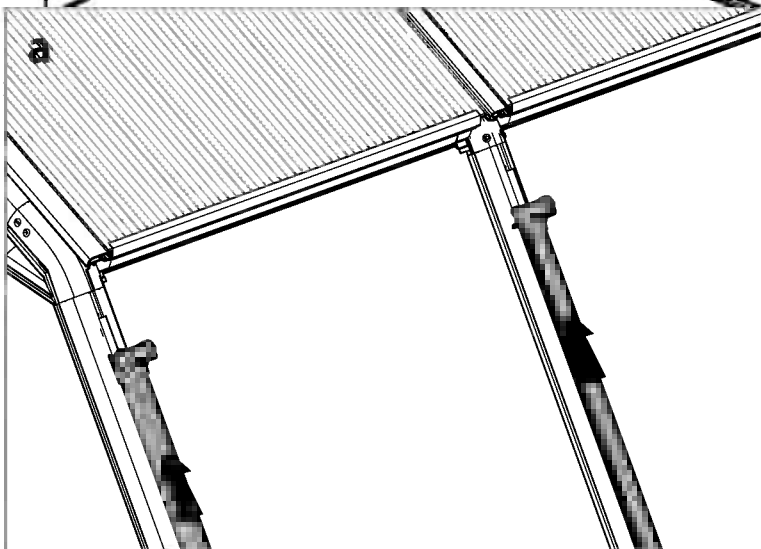
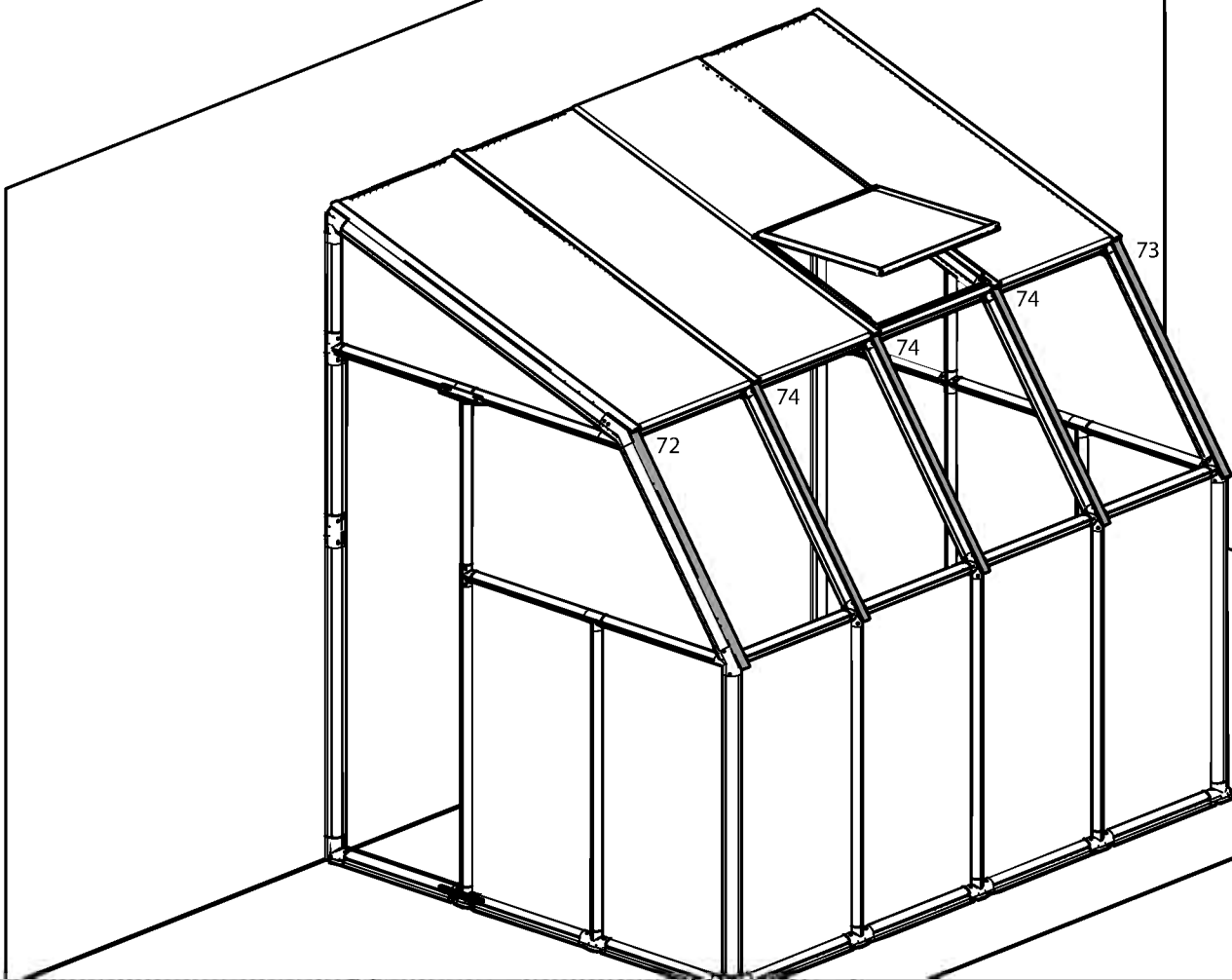
Item		Qty.
4043		5

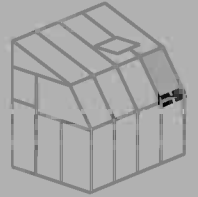

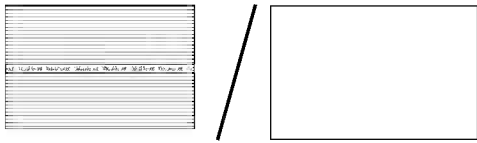
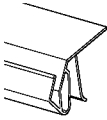

Item		Qty.
PN55		1
7552		1
4043		1
73		1

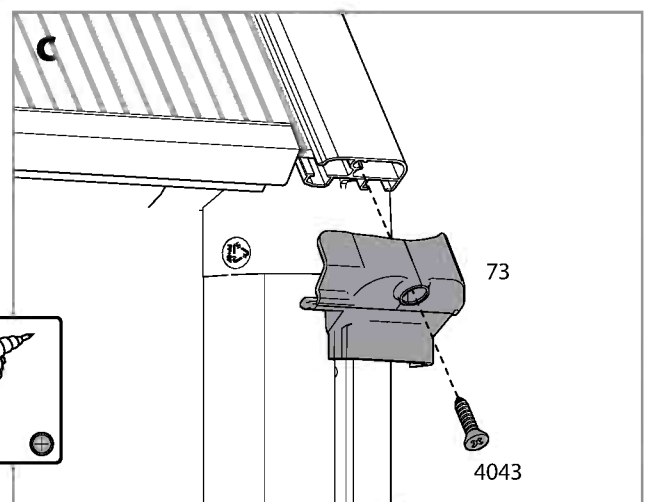
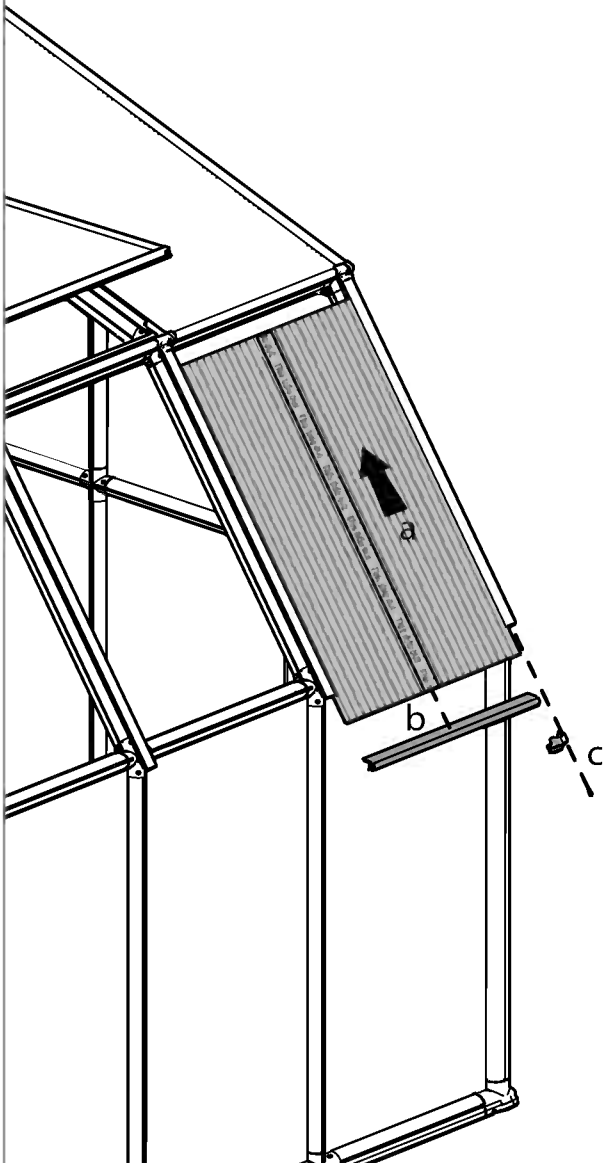
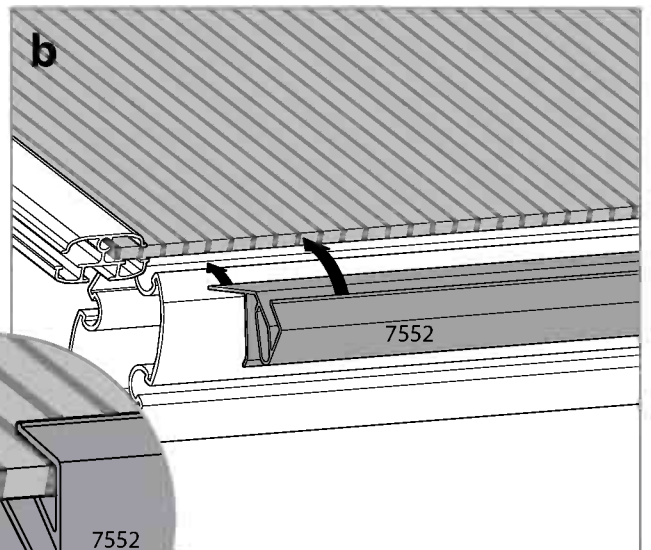
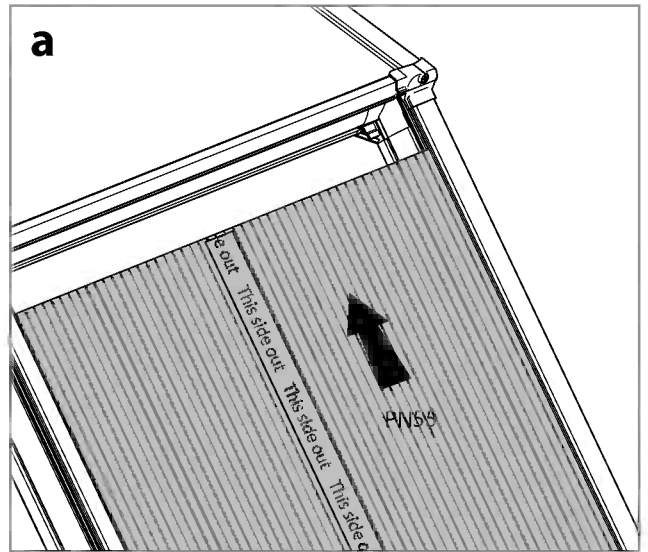

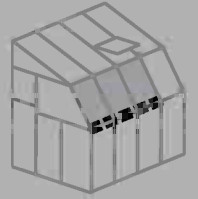

Item		Qty.
PN55		3
7552		3
4043		4

Item		Qty.
72		1
74		3

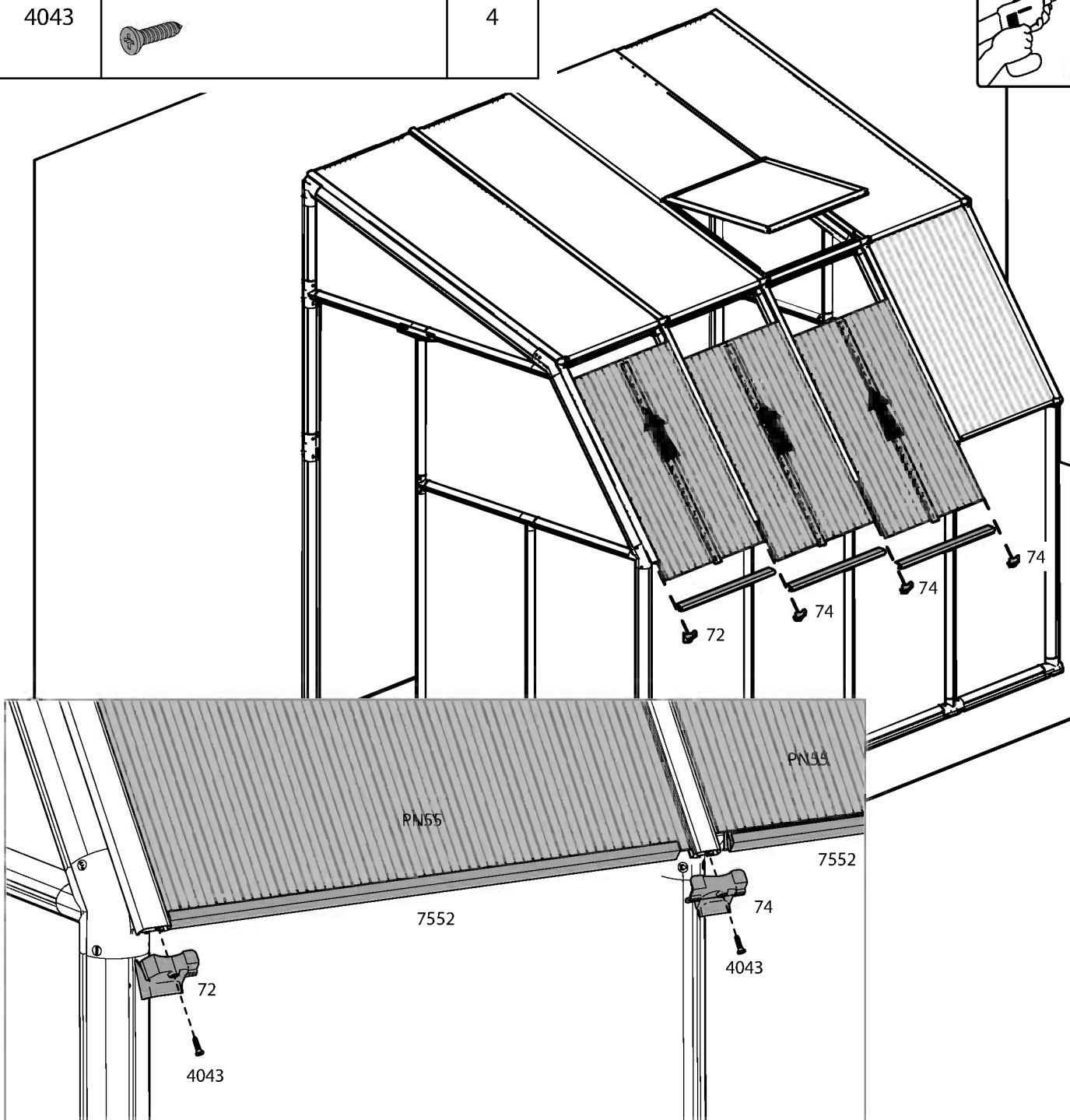
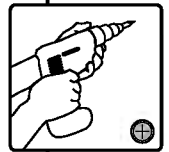

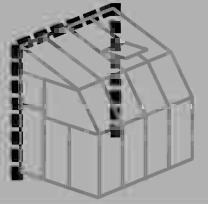

CAULK / SILICON

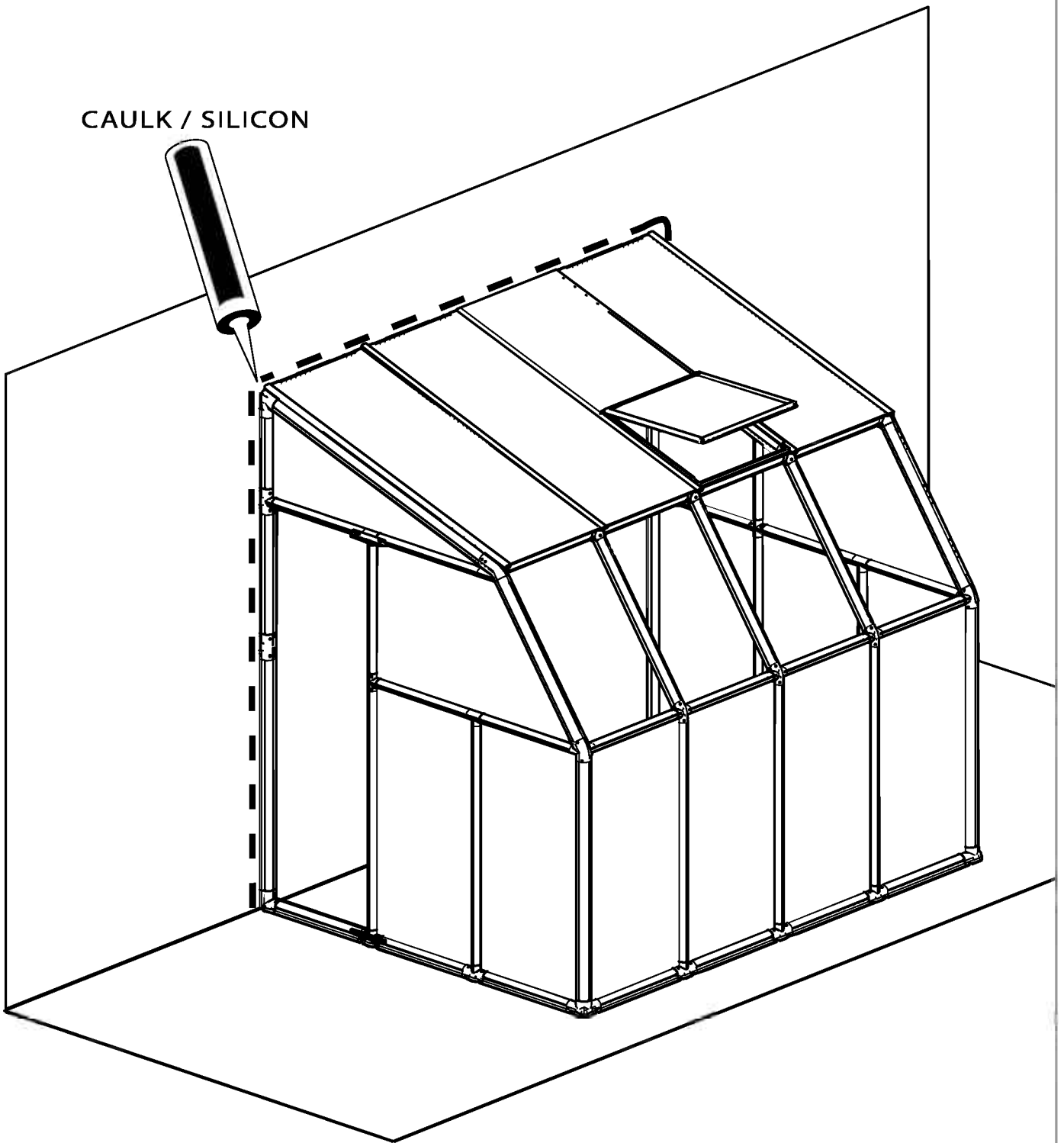

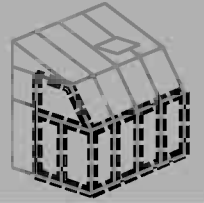

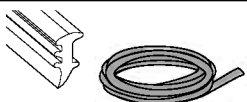
Item		Qty.
GF		

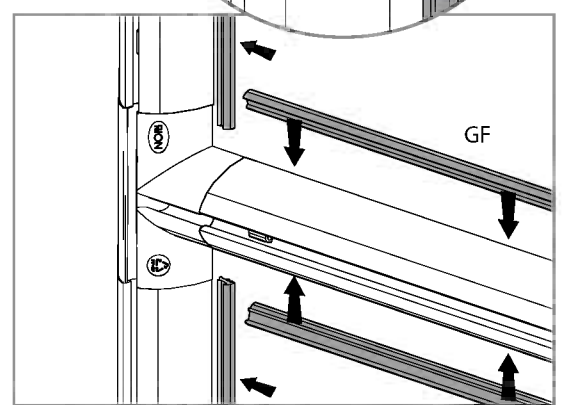
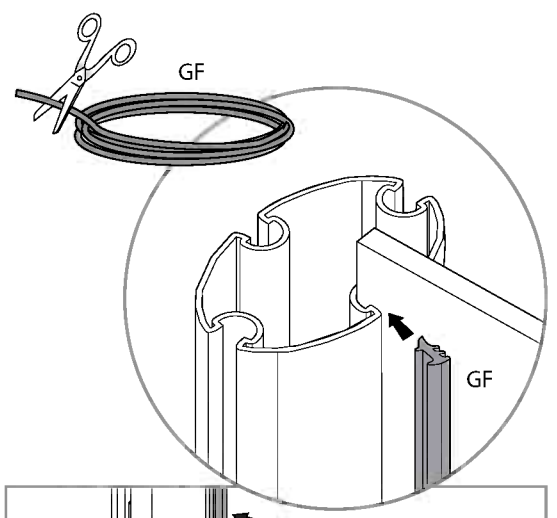
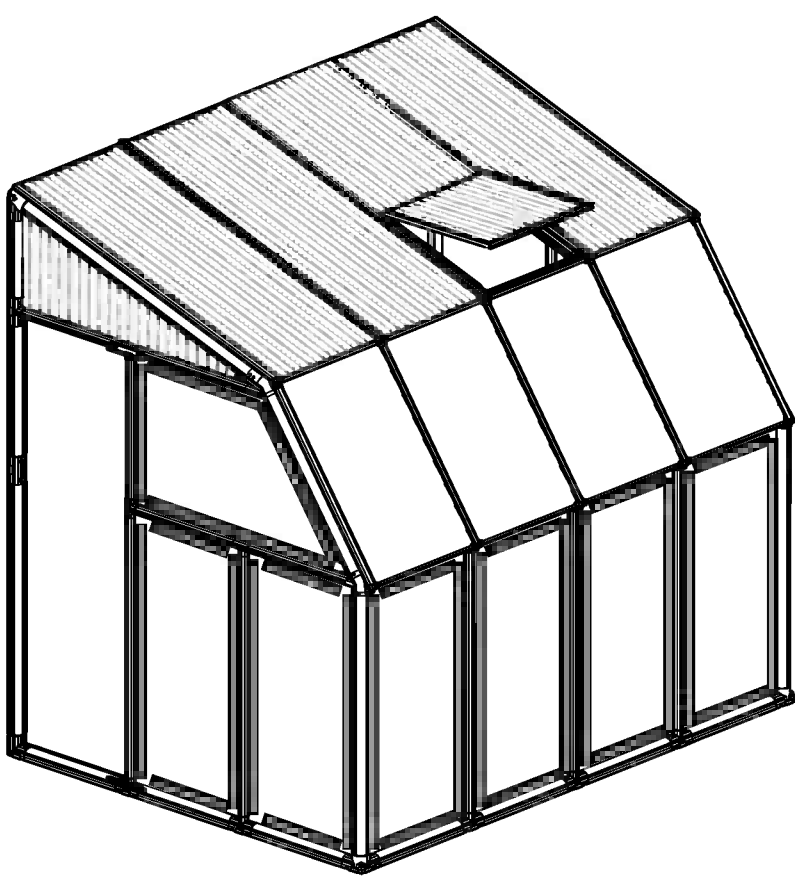
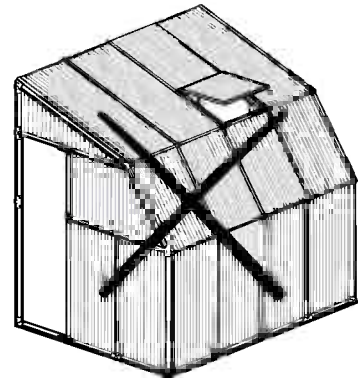
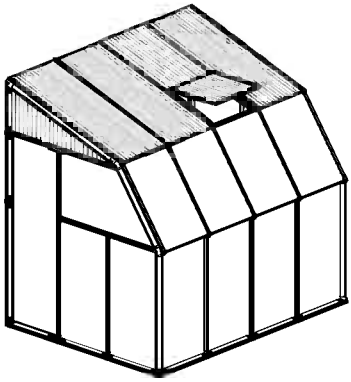

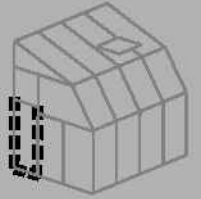

Item		Qty.
E1		2
E100		1
18		2
466		2
7224		2
7215 / 7216		1
pin1		4

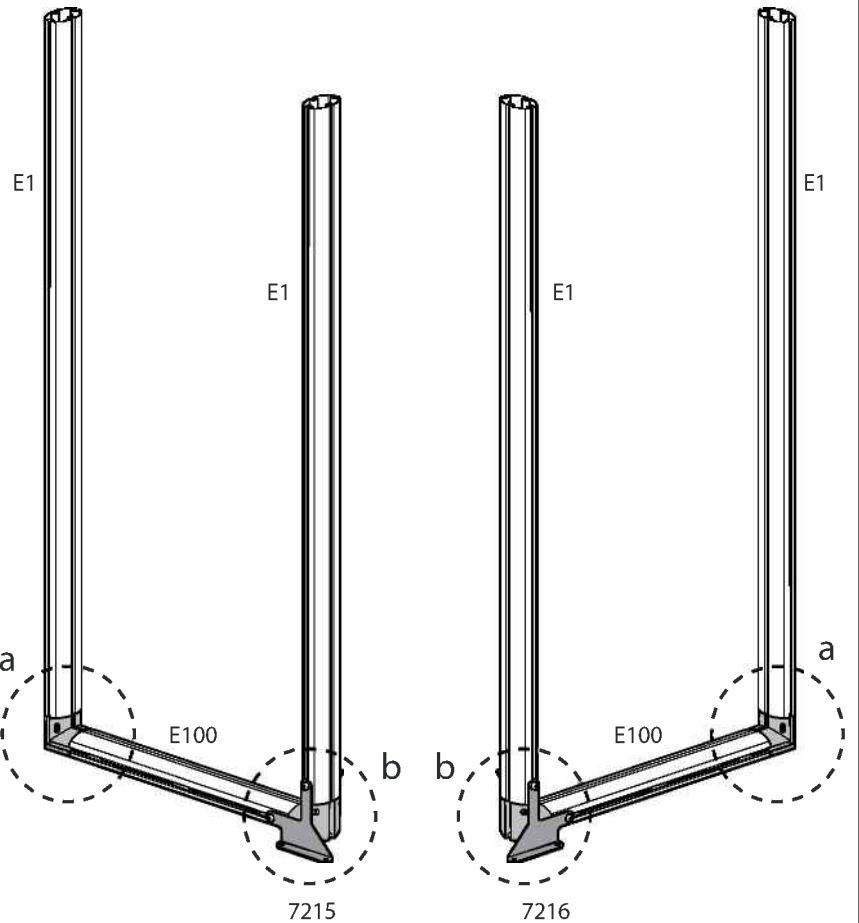
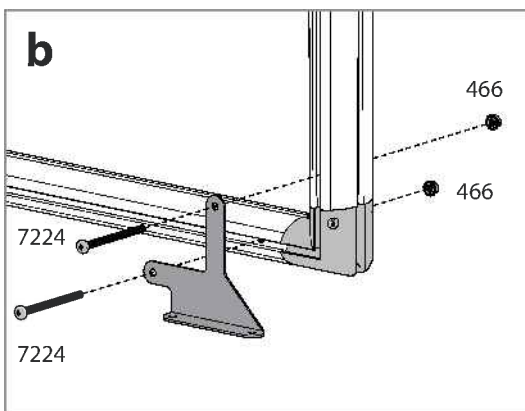
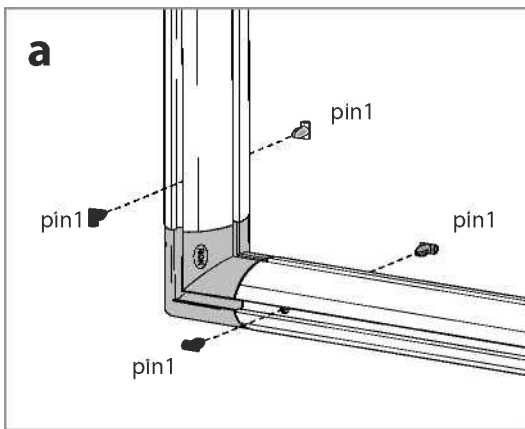
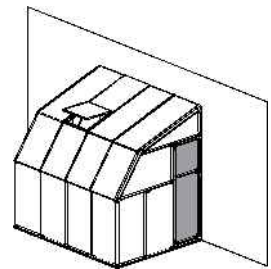
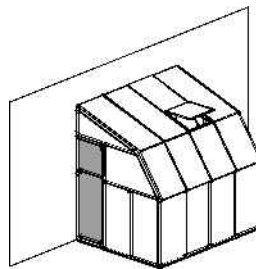
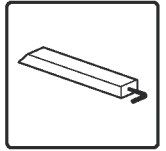
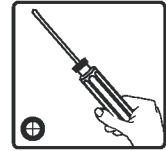

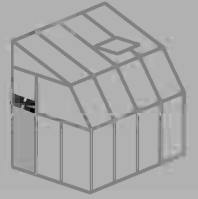



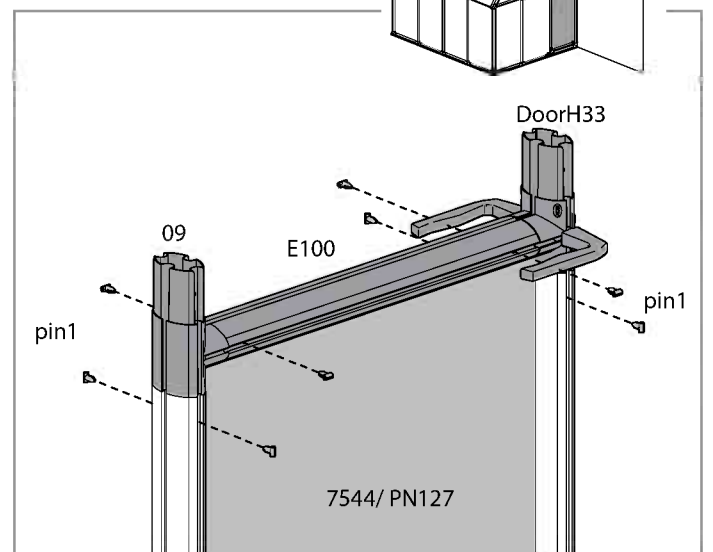
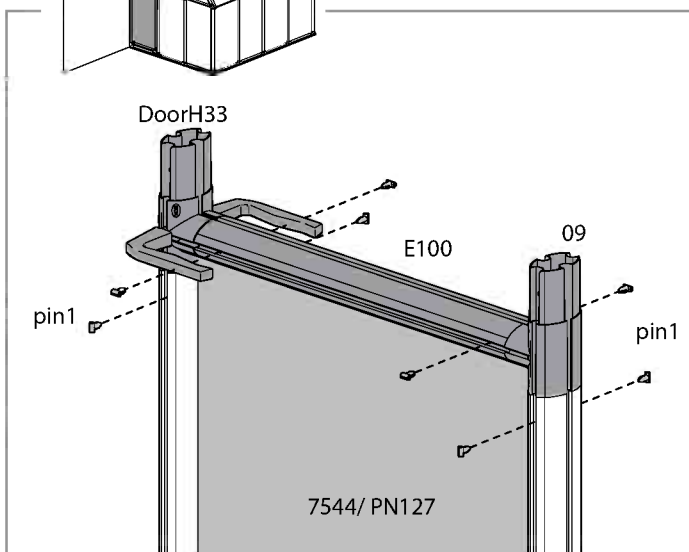
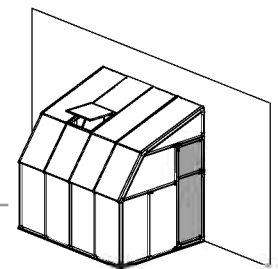
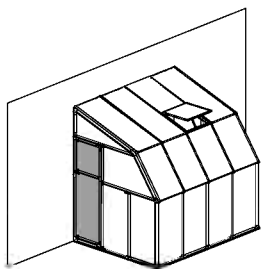
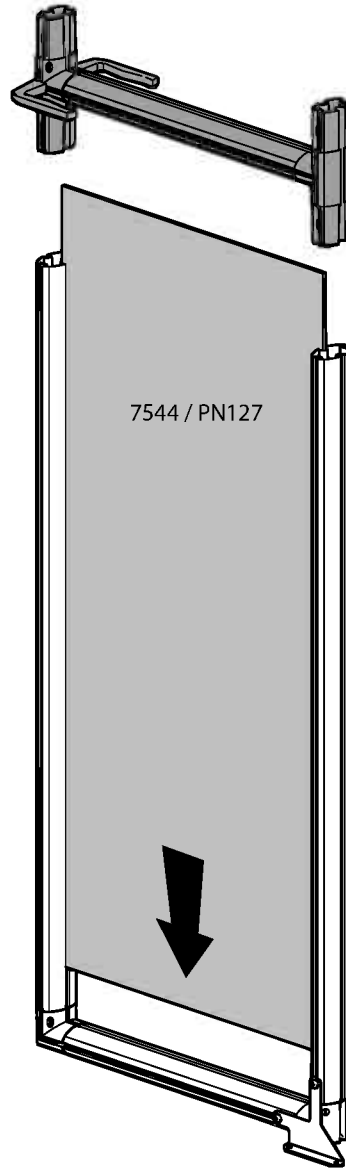

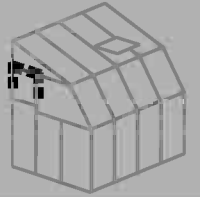

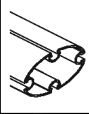
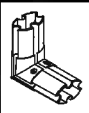
Item		Qty.
7544/ PN127		1
E100		2
09		1
DoorH33		1
pin1		8





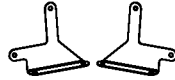

Item		Qty.
E102		2
E100		1
18		2
466		2

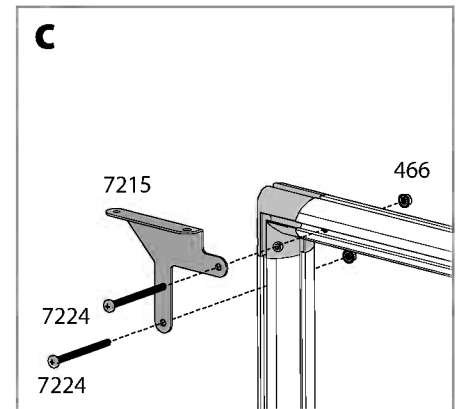
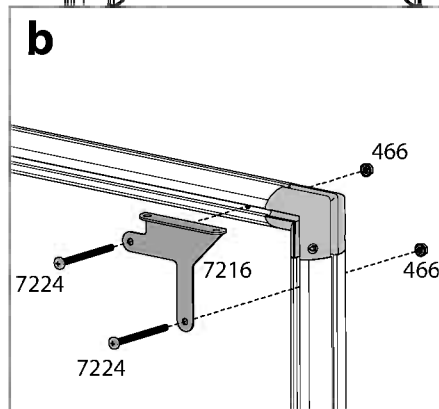
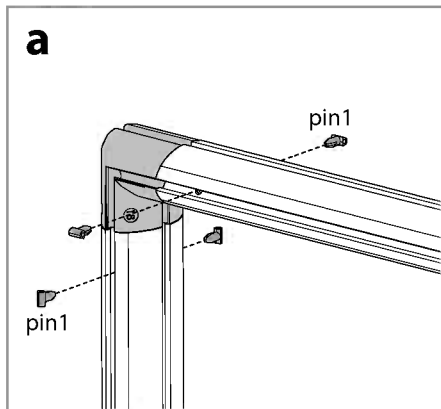
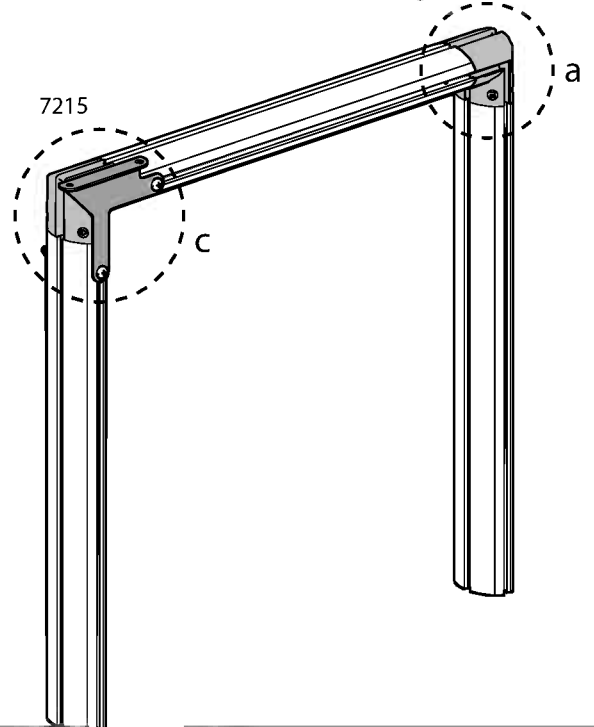
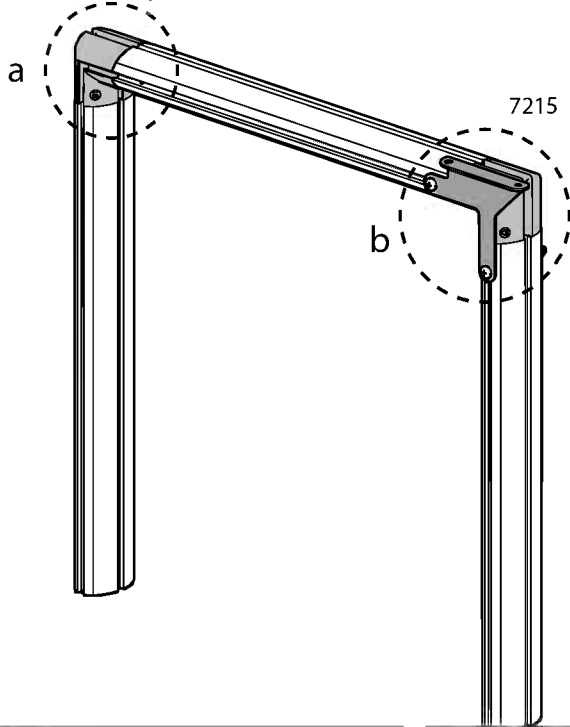
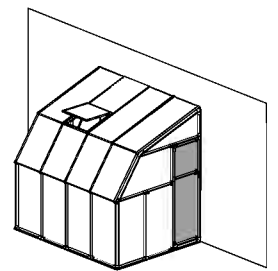
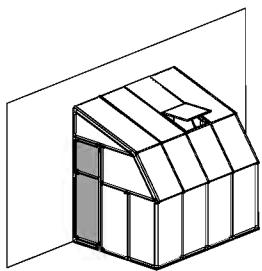
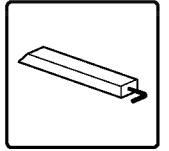
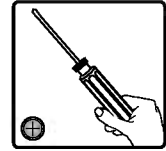
Item		Qty.
7224		2
7215 / 7216		1
pin1		4



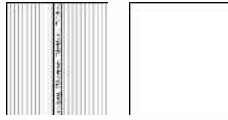

Item		Qty.
7616/ PN128		1
pin1		4

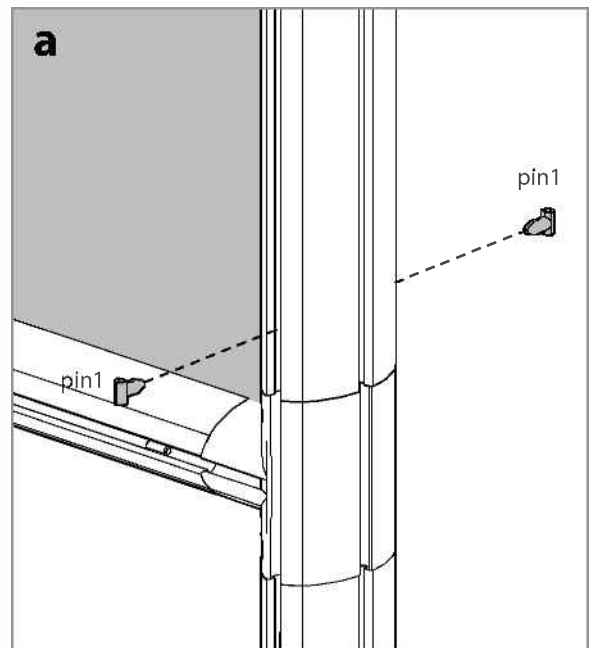
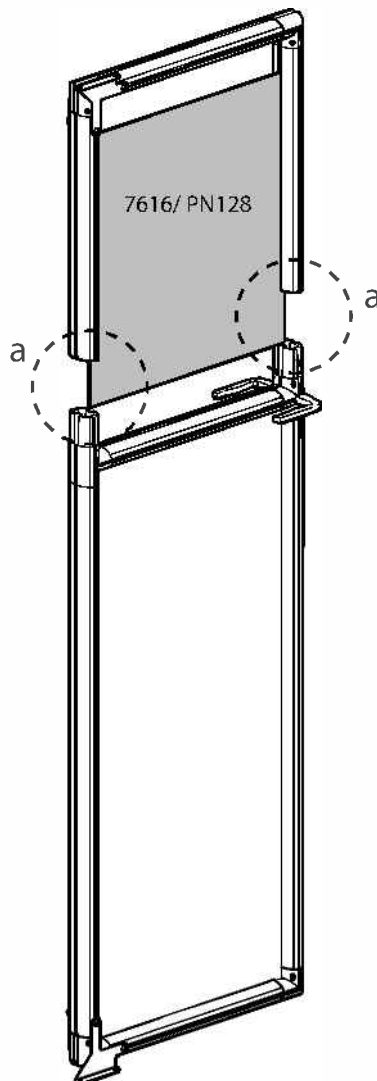
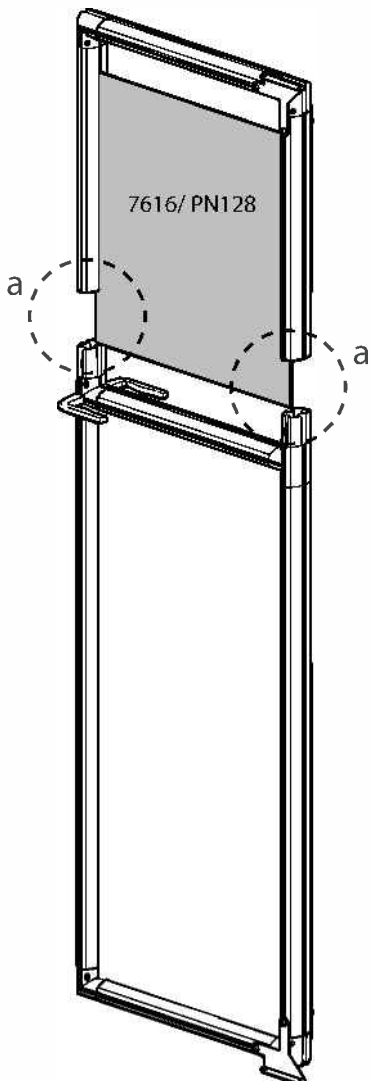
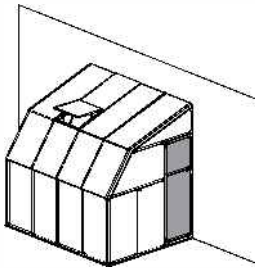
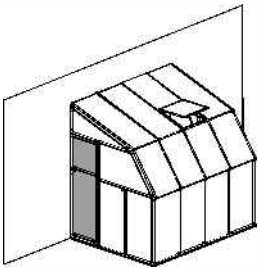
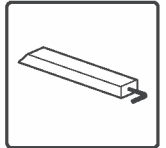

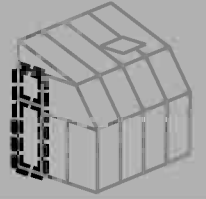

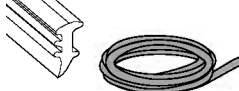
Item		Qty.
GF		

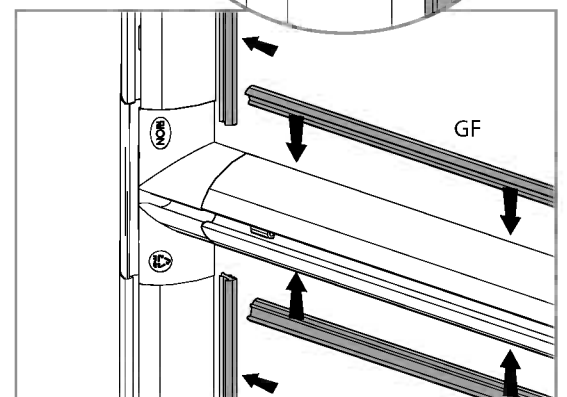
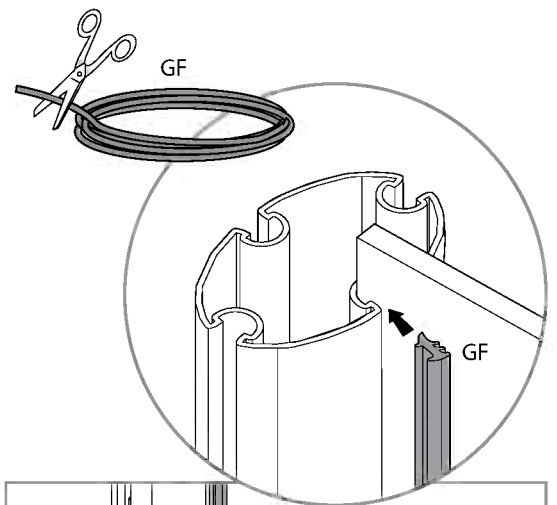
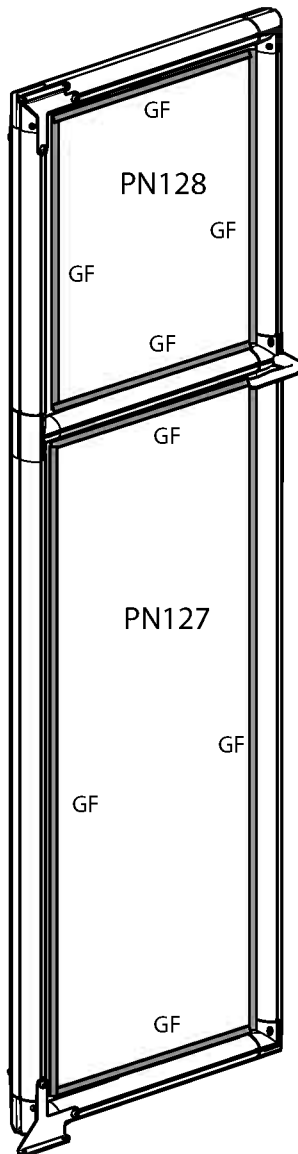
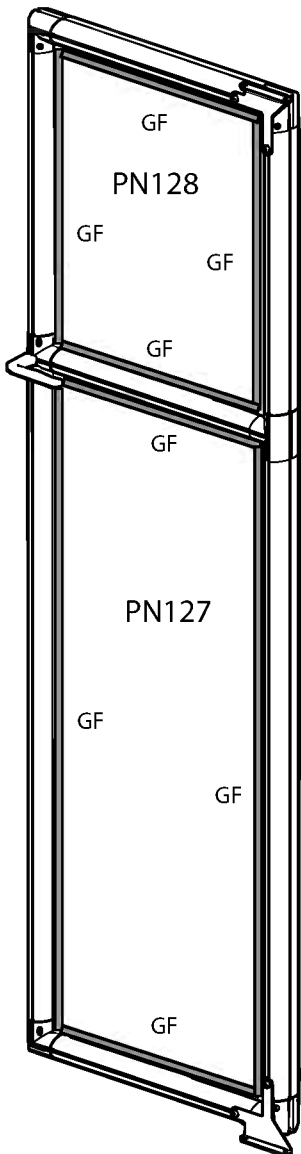
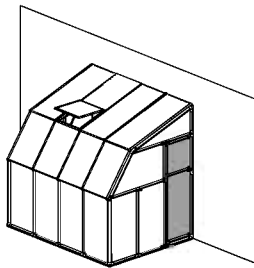
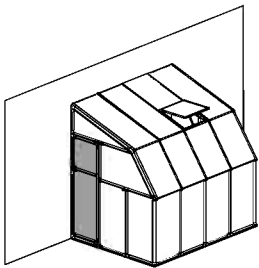
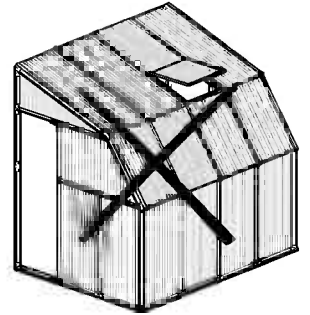
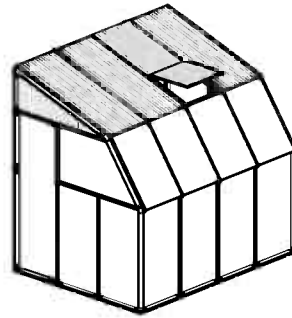
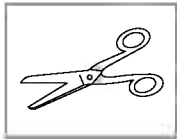

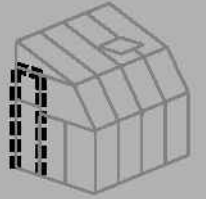

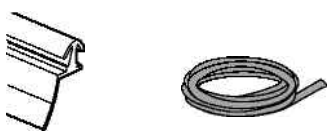

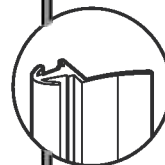
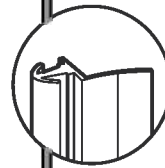
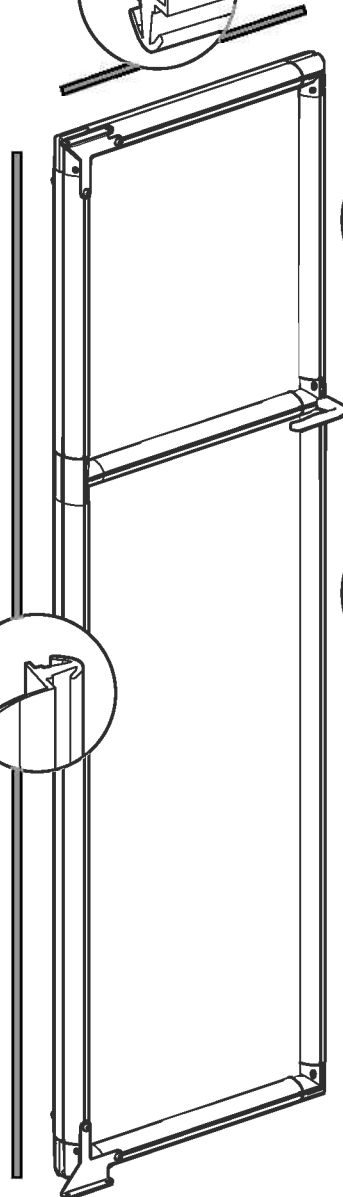
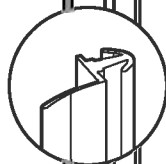
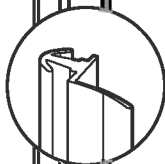
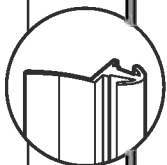
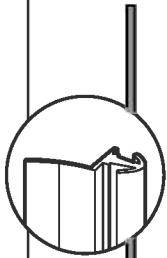
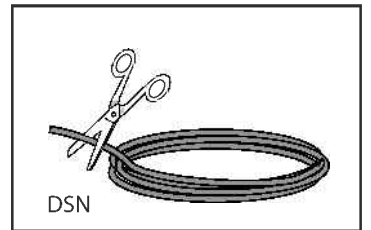
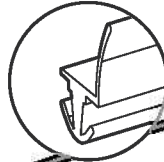
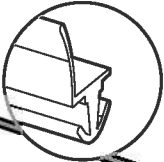
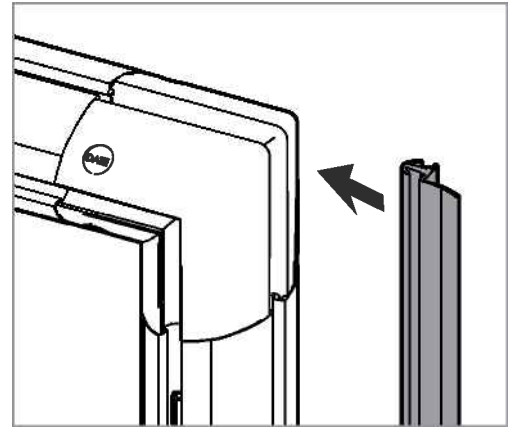
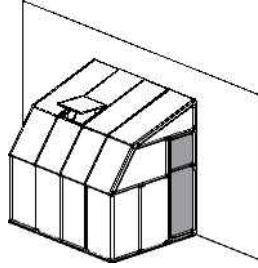
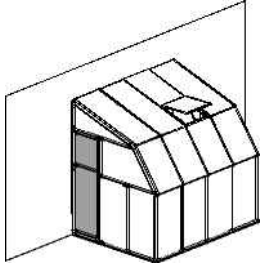
Item		Qty.
DSN		1

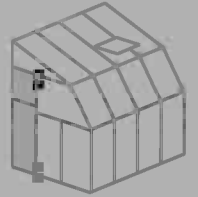



Item		Qty.
4016		2
7279		2
425		2

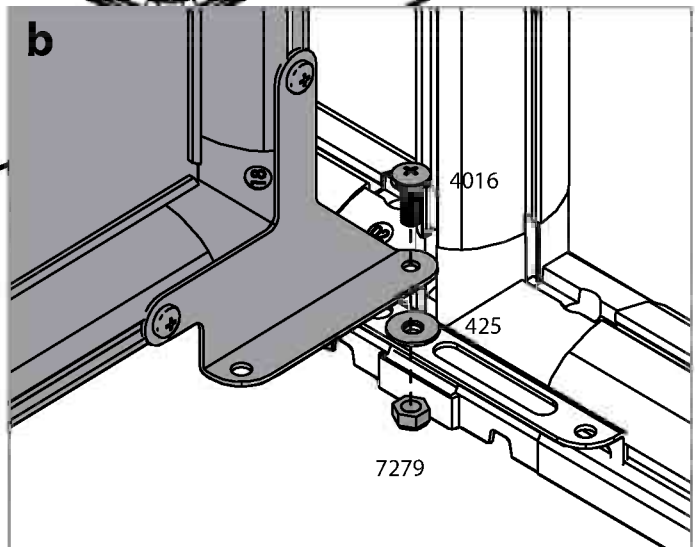
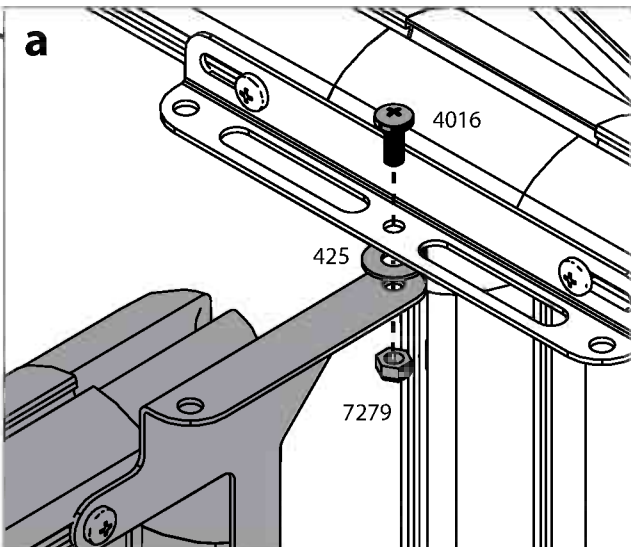
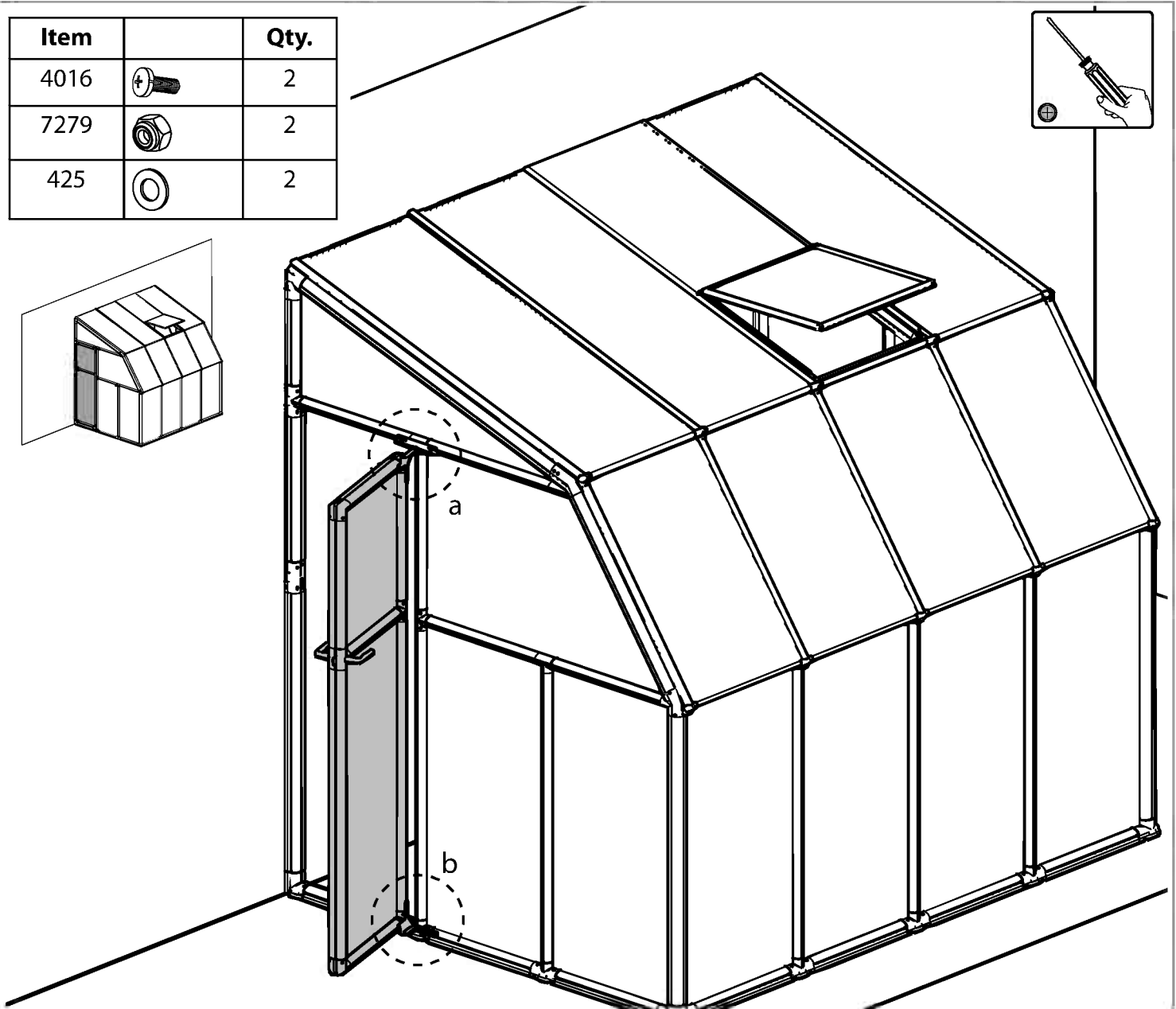
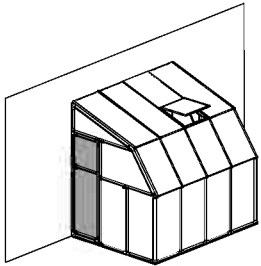
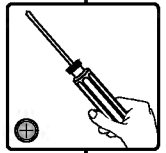

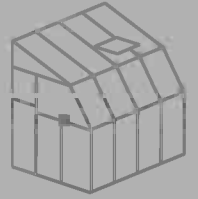

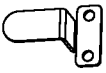
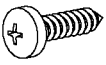
Item		Qty.
7273		1
7281		2

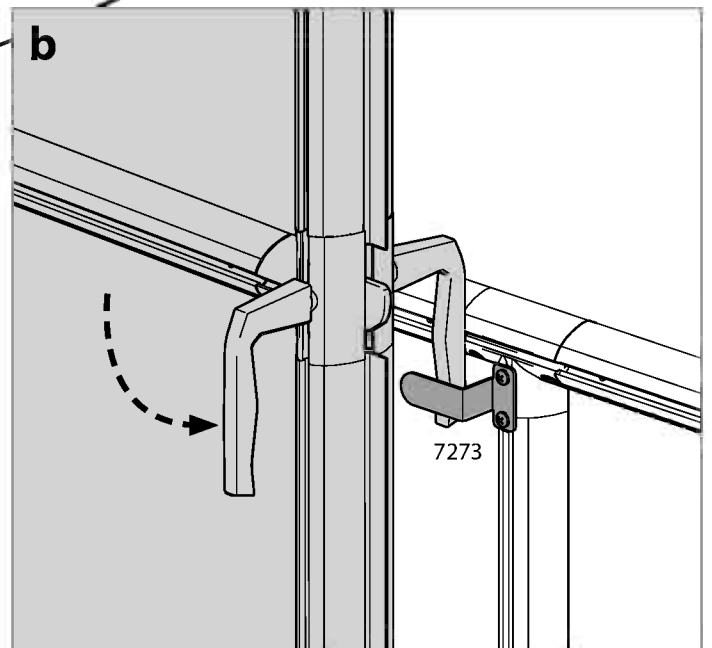
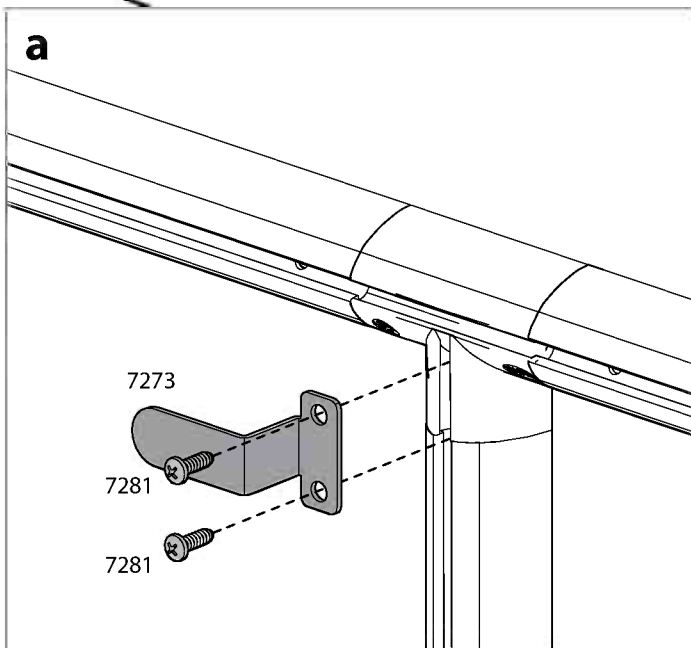
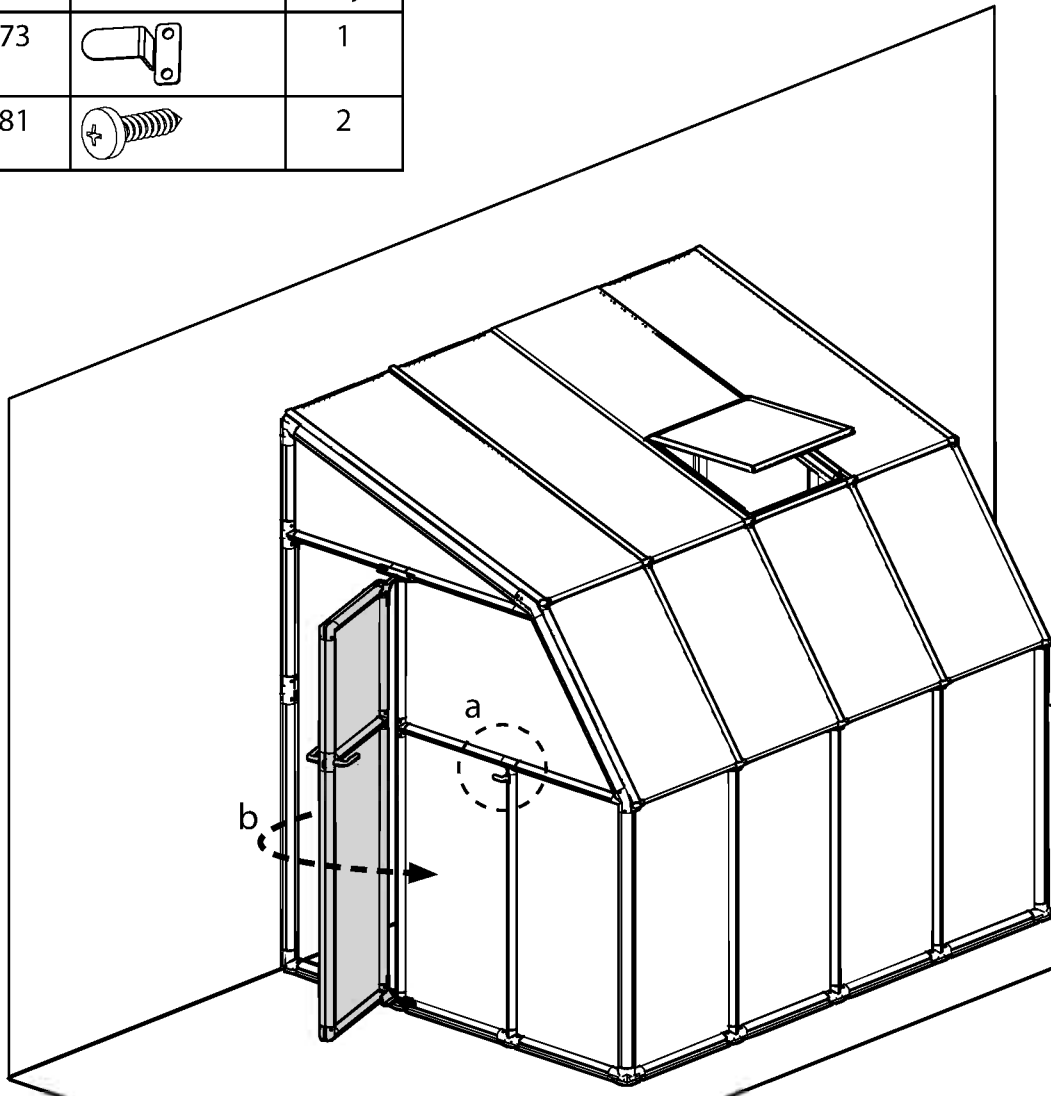
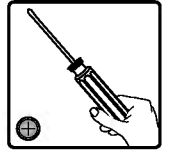

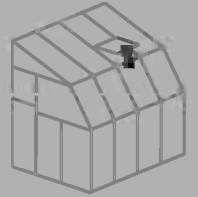

Item		Qty.
99		1
22		1
7441		1
7220		1
466		2

