

Assembly Instructions

Snap & Grow 8'x8'

Approx. Dim.

254x249x260cm / 100"x98"x102.3"

In case of addition SNAP & GROW 8x4 Extension Kit purchase –
Please refer to the assembly instruction provided in the 4' Extension Kit Box Only

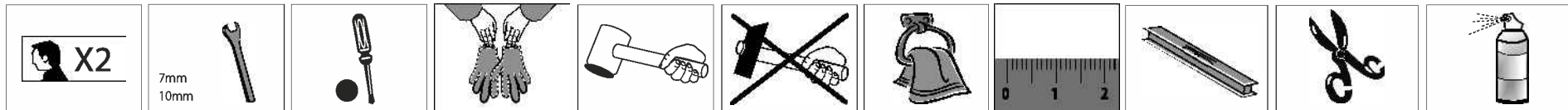

After Sale Service

Email: customer.service@palram.com

USA 877-627-8476
Canada 1 800-866-5749

England 01302-380775
Germany 0180-522-8778

France 0169-791-094
International +972 4-848-6942

www.palramapplications.com

IMPORTANT

Please read these instructions carefully before you start to assemble this greenhouse.
Please carry out the steps in the order set out in these instructions.
Keep these instructions in a safe place for future reference.

» Safety Advice

We strongly recommend the use of work gloves during assembly. Do not attempt to assemble the greenhouse in windy or wet conditions.

Do not touch overhead power cables with the aluminum profiles. Always wear shoes and safety goggles when working with extruded aluminum. Dispose of all plastic bags safely - keep them out of reach of small children. The greenhouse must be positioned and fixed on a flat level surface. Do not lean against or push the greenhouse during construction. Keep children away from the assembly area. Do not position your greenhouse in an area exposed to excessive wind.

Do not attempt to assemble this greenhouse if you are tired, have taken drugs or alcohol or if you are prone to dizzy spells. If using a step ladder or power tools ensure that you follow the manufacturers safety advice. Hot items such as recently used grills, blowtorches, should be kept away from the greenhouse walls.

We recommend the greenhouse is bolted to a concrete base or slabs (fix hinges are not supplied). However, if you want to fix directly in to the ground ensure there are no hidden pipes or cables in the ground before inserting the pegs.

» Care & Maintenance

When your greenhouse needs to be cleaned, use a mild detergent solution and rinse with cold clean water. DO NOT use acetone, abrasive cleaners or other special detergents to clean the clear panels.

For replacement parts - call our service line.

For additional information please visit our web site: www.palramapplications.com

» Tools & Equipment

- Tape measure
- Work gloves
- Plastic or rubber mallet
- Phillips head screwdriver
- Step ladder
- Scissors
- Spirit level - For base alignment
- Cloth

» General Advice

This multi-part assembly is best achieved by two people. Allow at least half a day for the assembly process.

Site selection instruction-choose a sunny level position away from overhanging trees. If you are fixing your greenhouse directly to a solid concrete foundation use the pre drilled holes in the metal base supplied. The component parts should be checked and laid out close at hand. Keep all small parts (screws etc.) in a bowl so they do not get lost.

- Sort the parts and check against the contents parts list.
- Carry out the assembly steps in the order set out in the instructions.
- The front of the greenhouse is the wall including the door, and the back is the opposite wall.
- After assembly fit the greenhouse to the base using connectors no. 924 and fit the whole unit to a leveled final
- You may use Silicon lubricant spray in order to help you slide the profiles on the connectors. Do not spray the Polycarbonate panels. Use the rubber mallet if necessary. Avoid shaking the plastic connectors.



» Notes (by steps)

Step 4: Profile 848 should be placed on the left hand side to be connected to profile 849. Profile 848 is the one with the connector at the end.

Step 5: After connecting profiles 816 to each other clean the connection area using a cloth. Place the cover strip on the connection only when it is clean and dry. Press the cover strip from one side of the connection to the other as mentioned in picture 4.

Step 8: Profile 835 & 836 should be aligned and connected according to the illustration on page 8 a & b. plug 23 should be inserted to each connection while the two dots on the front of the plug should be in horizontal position for easy assembly.

Step 10: Use part 95 as a template in order to measure the gap between posts 800 & 801 of the greenhouse wall and roof area.

Step 11: Profile 841 should be placed on the right hand side. Profile 840 should be placed on the left hand side when viewed from the front.

Step 12: Slide the panel 566 till the end of the rail and insert it into it's final position as shown in illustration c.

Step 19: Be careful to assemble the window in the position as shown on picture 20 a. profile 809 should be placed while the vent is closed to cover any gap. Ensure profile 809 is fitted correctly as shown on picture 20 b. The lip on 809 should face toward the gutter.

Step 22: Slide the panel 566 till the end of the rail and insert it into it's final position as shown in illustration a and b.

Step 23: Step inside the greenhouse and turn all 23 plugs a 1/4 of a turn clockwise.

Step 24: Profiles 814 should be inserted from the four corners of the greenhouse, then insert profile 815 in between them.

Step 25: Ensure you use long screw 450 to secure the door catch 363 as shown in illustration b.

Tighten all screws when completing assembly.

WICHTIG

Bitte lesen Sie diese Anweisungen sorgfältig durch, bevor Sie mit dem Aufbau des Gewächshauses beginnen.
Führen Sie den Aufbau in der in den Gebrauchsanweisungen aufgeführten Reihenfolge aus.
Heben Sie diese Anweisungen an einem sicheren Ort auf.

» Sicherheitshinweise:

Wir empfehlen wärmstens, während des Aufbaus Arbeitshandschuhe zu tragen.
Versuchen Sie nicht das Gewächshaus bei windigem oder regnerischem Wetter zusammenzubauen.
Berühren Sie mit den Aluminiumprofilen keine Oberleitungen.
Tragen Sie immer Schuhe und eine Schutzbrille beim Arbeiten mit Stranggepresstem Aluminium.
Entsorgen Sie alle Plastiktüten sicher – bewahren Sie sie außerhalb der Reichweite von kleinen Kindern auf.
Das Gewächshaus muss auf einem flachen, ebenen Untergrund aufgebaut und befestigt werden.
Während des Aufbaus sollten Sie sich nicht gegen das Gewächshaus lehnen oder es schieben.
Halten Sie Kinder vom Aufbaubereich fern.
Bauen Sie Ihr Gewächshaus nicht an Orten mit hoher Windbelastung auf.
Versuchen Sie nicht, dieses Gewächshaus aufzubauen, wenn Sie müde sind, unter dem Einfluss von Medikamenten Alkohol stehen, oder wenn Sie zu Schwindelanfällen neigen.
Bei Verwendung einer Stehleiter oder Elektrowerkzeuge, befolgen Sie die Sicherheitshinweise des Herstellers.
Heiße Geräte wie kürzlich benutzte Grills, Schneidbrenner usw. sollten von den Wänden des Gewächshauses ferngehalten werden.
Wir empfehlen das Gewächshaus auf einem Betonfundament oder Platten zu befestigen (Die Scharniere zum Fixieren sind nicht im Lieferumfang).
Sollten Sie sich entscheiden das Gewächshaus mit den Heringen direkt an den Boden zu fixieren, stellen Sie erst sicher, dass keine versteckten Rohre oder Kabeln in den Boden sich befinden.

» Pflege und Wartung

Benutzen Sie eine milde Reinigungslösung für die Reinigung Ihres Gewächshauses und spülen Sie es danach mit kaltem, sauberem Wasser ab.
Benutzen Sie AUF KEINEN FALL Azeton, Scheuermittel oder andere spezielle Reinigungsmittel zur Reinigung der klaren Platten.
Falls Sie Ersatzteile brauchen - rufen Sie unseren Kundendienst an.
Für weitere Informationen besuchen Sie bitte unsere Website: www.palramapplications.com

» Werkzeuge u. Ausrüstung

- Maßbtshandschuhe
- Kunststoff- oder Gummihammer
- Kreuzschlitzschraubenzieher
- Stufenleiter
- Schere
- Wasserwaage - Für Basisausrichtung
- Tuch

» Allgemeine Hinweise

Der Zusammenbau der Teile wird am besten von zwei Leuten bewältigt.
Rechnen Sie mit mindestens einem halben Tag für den Zusammenbau.
Standortauswahl- Wählen Sie eine sonnige rechtwinklige Stelle ohne überhängende Bäume.
Wenn Sie Ihr Gewächshaus direkt auf einem festen Betonfundament fixieren, sollten Sie dafür die vorgebohrte Löcher in der gelieferten Metallbasis benutzen.
Alle Bauteile sollten Ihrer Nähe auf dem Boden ausgelegt und sortiert werden und anhand der Inhaltsliste überprüft werden.
Bewahren Sie alle Kleinteile (Schrauben usw..) in einer Schüssel, damit sie nicht verloren gehen.

- Führen Sie den Aufbau in der in den Gebrauchsanweisungen aufgeführten Reihenfolge aus.
- Die Vorderseite des Gewächshauses ist die Wand mit der Tür, und die Rückseite ist die gegenüberliegende Wand.
- Sie können Silikonfett- Spray verwenden, um das Schieben der Profile 924 auf die Anschlüsse zu erleichtern.
- Sprühen Sie nicht auf die Polycarbonatplatten.
- Verwenden Sie den Gummihammer, falls nötig.
- Vermeiden Sie das Schütteln der Kunststoffanschlüsse.

**» Fußnoten: (in Schritten)**

Schritt 4: Profil 848 sollte auf der linken Seite, um zum Profil 849 angeschlossen zu werden. Profil 848 ist das Profil mit dem Verbindungsstück am Ende.

Schritt 5: Nach dem gegenseitigen Zusammenschließen von Profilen 816, reinigen Sie den Anschlussbereich mit einem Tuch. Legen Sie das Abdeckband auf die Verbindung nur wenn es sauber und trocken ist. Drücken Sie das Abdeckband von der einen Seite der Verbindung zum anderen, wie in Bild 4 gezeigt wird.

Schritt 8: Profil 835 & 836 sollten entsprechend der Abbildung auf Seite 8a und b ausgerichtet und angeschlossen werden. Stöpsel Nr. 23 sollte in jeder Verbindung eingesetzt werden, während die beiden

Punkte auf der Vorderseite des Stöpsels in einer horizontalen Position sein müssen damit diesen leichter eingeführt werden kann.

Schritt 10: Verwenden Sie Teil Nr. 95 als Vorlage, um die Lücke zwischen Pfosten 800 u. 801 des Gewächshauses im Wand- und Dachbereich zu messen.

Schritt 11: Profil 841 sollte auf der rechten Seite platziert werden. Profil 840 sollte auf der linken Seite platziert werden, wenn von vorne betrachtet.

Schritt 12: Schieben Sie das Paneel 566 bis zum Ende der Schiene und stecken Sie dieses in seiner endgültigen Position wie in Illustration c dargestellt wird.

Schritt 19: Achten Sie darauf das Fenster in die richtige Position, wie auf Bild 20a gezeigt wird, zu montieren. Profil 809 sollte gelegt werden, während die Entlüftung geschlossen ist, um jede Lücke zu vermeiden. Stellen Sie sicher, dass das Profil 809 richtig montiert ist, wie auf Bild 20 b. gezeigt wird. Die Lippe auf 809 sollte in Richtung Regenrinne zeigen.

Schritt 22: Schieben Sie das Paneel 566 bis zum Ende der Schiene und stecken Sie dieses in seiner endgültigen Position wie in Illustration a. u. b dargestellt wird.

Schritt 23: Treten Sie ein in das Gewächshaus und drehen Sie alle 23 Verbindungsstücke einen 1/4 der Uhrzeigersinnrichtung

Schritt 24: Profile 814 soll von den vier Ecken des Gewächshauses eingefügt werden legen Sie dann Profil 815 dazwischen.

Schritt 25: Stellen Sie sicher, dass Sie die lange Schraube 450 verwenden um den Türhänger 363 zu sichern, wie in Abbildung b gezeigt wird.

Alle Schrauben befestigen nach dem Abschluss der Montage

IMPORTANT

Lisez attentivement ces consignes avant de commencer le montage de la serre.
Suivez l'ordre des étapes de montage.
Respectez les étapes de montage définies dans cette notice.
Conservez ces consignes de montage dans un endroit sûr, pour référence future.

» **Consigne de sécurité**

Il est recommandé d'utiliser des gants de travail lors du montage de la serre.
N'essayez pas de monter la serre par temps de pluie ou par grands vents.
Veillez à ne pas toucher de fils électriques avec les profils en aluminium. Veillez à toujours porter des chaussures et des lunettes de protection lorsque vous manipulez des copeaux d'aluminium. Rangez soigneusement et à l'abri tous les sacs en plastique, hors de la portée des enfants. La serre doit être posée et fixée sur une surface plane. Veillez à ne rien poser contre la serre lors de son montage ou n'exercer de pression sur elle. Éloignez les enfants de la zone de montage. Ne placez pas votre serre sur une zone exposée à des vents forts (Cette serre ne supporte pas des vents > 70 km/h).
N'essayez pas de monter cette serre si vous êtes fatigué, après avoir pris des médicaments ou bu de l'alcool ou si vous êtes sujet à des étourdissements. Si vous utilisez un escabeau, veillez à suivre les consignes de sécurité du fabricant. Ne laissez jamais dans la serre des objets chauds tels que des grils récemment utilisés, des lampes à souder, etc.
Il est recommandé de fixer la serre au sol. Cependant, si vous voulez la fixer, vérifiez qu'il n'y a aucun tuyau ou câble dans le sol avant d'y enfoncer les pieux.

» **Service clientèle**

PouVr nettoyer la serre, utilisez un produit d'entretien doux et rincez à l'eau froide propre. N'UTILISEZ PAS d'acétone, de produits inflammables ou autres détergents spéciaux pour nettoyer les panneaux transparents. Pièces de rechange - Contactez le service clientèle au : Pour toute information complémentaire, veuillez consulter notre site : www.palramapplications.com

» **Entretien & Maintenance**

- Mètre
- Gants de travail
- Maillet en plastique ou en caoutchouc
- Tournevis cruciforme
- Escabeau
- Paire de ciseaux
- Niveau
- Chiffon

» **Conseil généraux**

Ce montage consiste en un assemblage de pièce, il sera plus simple de le monter à deux. Une demi-journée est nécessaire pour réaliser le montage. Sélection du site : choisissez un lieu ensoleillé et protégé des arbres. Si vous montez votre serre directement sur une base solide en béton, utilisez les trous déjà préparés sur la base en métal fournie. Les pièces du composant doivent être vérifiées et placées à portée de main. Mettez toutes les petites pièces (vis, etc.) dans une coupelle pour éviter de les perdre. Protégez le toit de la neige et des feuilles.

- Triez les pièces et vérifiez qu'il n'en manque aucune en comparant avec la liste des pièces détachées.
- Suivez l'ordre des étapes de montage.
- Le devant de la serre consiste en la paroi comprenant la porte et le mur opposé constituant l'arrière de la serre.
- Ensuite, assemblez correctement la serre à sa base, en utilisant les connecteurs n°35 et vérifiez que l'ensemble est de niveau.
- Vous pouvez utiliser un spray lubrifiant en silicone afin de vous aider à insérer les profils dans les connecteurs. Veillez à ne pas asperger les panneaux de polycarbonate. Utilisez le maillet en caoutchouc si nécessaire tout en prenant soin de ne pas abîmer les connecteurs en plastique.

» **Notes (by steps)**

Etape 4: Le profil 848 doit être placé sur la partie droite pour être connecté au profil 849. Le profil 848 est celui au connecteur situé à l'extrémité.

Etape 5: Après avoir connecté le profil 816 à tous les autres, nettoyez les zones de connexion avec le chiffon. Ne placez la bande couvrante qu'une fois la connexion sèche et propre. Apposez la bande couvrante de part et d'autre de la connexion, comme mentionné sur l'illustration 4.

Etape 8: Les profils 835 et 836 doivent être alignés et connectés comme indiqué sur l'illustration de la page 8 a et b. Les 23 prises doivent être insérées dans chaque connexion en veillant à ce que les deux points à l'avant de la prise soient à l'horizontal pour un assemblage plus simple.

Etape 10: Utilisez la partie 95 comme modèle afin de mesurer l'écart entre les poaux 800 et 801 du mur et du toit de la serre.

Etape 11: Le profil 841 doit être placé sur la partie droite. Le profil 840 doit être placé sur la partie gauche quand on les regarde depuis le devant de la serre.

Etape 12: Faire glisser le panneau 566 depuis la fin du rail et l'insérez dans sa position finale comme indiqué sur l'illustration c.

Etape 19: Faites attention à bien assembler la fenêtre comme indiquée sur l'illustration 20a. Le profil 809 doit être placé lorsque l'aération est fermée pour empêcher tout écart. Soyez sûr que le profil 809 correspond parfaitement à l'illustration 20b. Le bord du 809 doit être placé en direction de la gouttière.

Etape 22: Faire glisser le panneau 566 depuis la fin du rail et l'insérez dans sa position finale comme indiqué sur l'illustration a et b.

Etape 23: Entrez dans la serre et tourner les 23 prises à 1/4 de tour dans le sens des aiguilles d'une montre.

Etape 24: Les profils 814 doivent être insérés depuis les 4 coins de la serre, installez ensuite entre eux le profil 815.

Etape 25: Stellen Sie sicher, dass Sie die lange Schraube 450 verwenden um den Türfänger 363 zu sichern, wie in Abbildung b gezeigt wird.
Serrez toutes les vis après avoir achever l'assemblage.

IMPORTANTE

Por favor, lea con atención estas instrucciones antes que empiece el ensamblaje de este invernadero. Por favor, lleve a cabo los pasos especificados en estas instrucciones. Guarde estas instrucciones en un lugar seguro para su futura referencia.

» Consejo de Seguridad

Le recomendamos encarecidamente el uso de guantes durante el montaje. No trate de montar el invernadero en condiciones húmedas o de viento. No toque cables eléctricos aéreos con los perfiles de aluminio. En todo momento use zapatos y anteojos de seguridad cuando trabaje con aluminio extrusionado. Tire a la basura en forma segura todas las bolsitas de plástico, y manténgalas fuera del alcance de niños pequeños. El invernadero debe ser ubicado y fijado en una superficie plana y horizontal. No se apoye sobre, o no empuje el invernadero durante la construcción. Mantenga los niños alejados del área de la construcción. No ubique el invernadero en un área expuesta a vientos excesivos.

No intente montar el invernadero si Usted está cansado, si ha tomado medicinas o alcohol, o Usted es propenso a ataques de mareos. Si utiliza una escalera de mano o herramientas eléctricas, asegúrese de seguir las instrucciones de seguridad del fabricante. Objetos calientes tales como parrillas recién usadas, sopletes, deben mantenerse alejados de las paredes del invernadero.

Nosotros recomendamos que el invernadero sea atornillado a una base de hormigón o losas (bisagras de corrección no son suministradas). Sin embargo, si usted desea fijar directamente en el hormigón, asegúrese previamente de que no hay tuberías o cables ocultos en el suelo antes de insertar las clavijas.

» Cuidado y Mantenimiento

Cuando necesite limpiar el invernadero, utilice un detergente suave y enjuague con agua limpia fría. NO use acetona, limpiadores abrasivos o detergentes especiales para limpiar los paneles claros.

Para las piezas de repuesto - llame a nuestra línea de servicio.

Para obtener información adicional por favor visite nuestro sitio web:
www.palramapplications.com

» Herramientas & Equipos

- Cinta métrica
- Guantes de trabajo
- Mazo de plástico o de goma
- Destornillador de Cabeza Phillips
- Escalera de mano
- Tijera
- Nivel de burbuja - Para la alineación de la base
- Paño

» Consejo General

Este ensamblaje de varias partes se logra mejor por medio de dos personas. Calcule por lo menos medio día para el proceso de montaje.

Instrucción para la Selección del lugar - elija una ubicación soleada y nivelada horizontal, lejos de árboles sobresalientes. Si Usted va a fijar su invernadero directamente en un basamento de concreto sólido, use los agujeros pre-perforados en la base de metal suministrada.

Los componentes deben ser revisados y distribuidos, puestos a mano.

Mantenga todas las piezas pequeñas (tornillos, etc.) en un recipiente para que no se pierdan.

- Ordene las piezas y compruebe con el contenido de la lista de piezas.
- Lleve a cabo los pasos de montaje en el orden indicado en las instrucciones.
- La parte frontal del invernadero es la pared incluyendo la puerta, y la parte posterior es la pared de enfrente.
- Después del montaje fije el invernadero a la base mediante los conectores no. 924 y coloque la unidad entera a una final nivelada.
- Usted puede utilizar el aerosol de lubricante de silicona para ayudar a deslizar los perfiles en los conectores. No rocíe los paneles de policarbonato. Use el mazo de goma si fuere necesario.



» Notas (Por Etapas)

Etapa 4: Perfil 848 debe ser puesto en el lado izquierdo para ser conectado al perfil 849. Perfil 848 es el que tiene el conector situado en el extremo.

Etapa 5: Después de conectar los perfiles 816 unos a otros, limpiar la zona de conexión con un paño. Coloque el listón de cobertura en la conexión sólo cuando esté limpia y seca. Presione el listón de cobertura de un lado de la conexión a la otra como se menciona en la figura 4.

Etapa 8: Perfiles 835 y 836 deben alinearse y conectarse según la ilustración en la página 8 a y b. El tapón 23 debe insertarse a cada conexión, mientras que los dos puntos en el frente del tapón debe estar en posición horizontal para facilitar su montaje.

Etapa 10: Use la parte 95 como una plantilla con el fin de medir la brecha entre los postes 800 y 801 de la pared del invernadero y el área del techo.

Etapa 11: Perfil 841 debe ser puesto a mano derecha. Perfil 840 debe ser colocado en el lado izquierdo cuando se mira desde el frente.

Etapa 12: Deslice el panel de 566 hasta el fin del riel e insértelo en su posición final como se muestra en la ilustración c.

Etapa 19: Tenga cuidado al montar la ventana en la posición como se muestra en la Foto 20 a. Perfil 809 debe ser colocado mientras que la ventilación está cerrada para cubrir cualquier abertura.

Asegúrese de que el perfil 809 está correctamente equipado como se muestra en la foto 20 b. El labio en el 809 debe mirar hacia la cuneta.























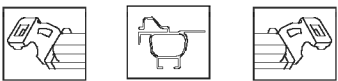



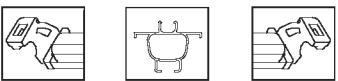

Etapa 22: Deslice el panel de 556 hasta el fin del riel E insértelo en su posición final como se muestra en la ilustración a y b.

Etapa 23: Entre al interior del invernadero y gire todos los 23 tapones un 1/4 de vuelta hacia la derecha.











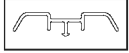
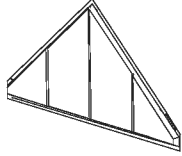

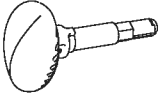
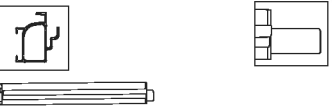

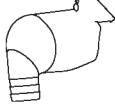

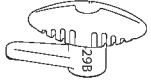

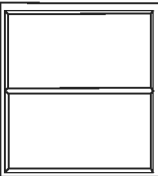
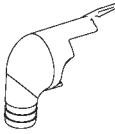

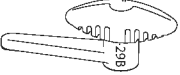
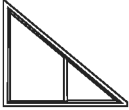
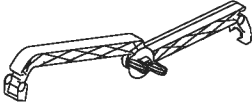
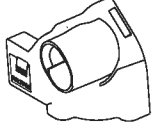
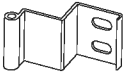
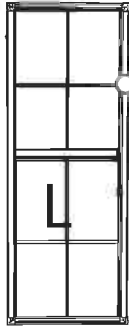
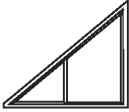

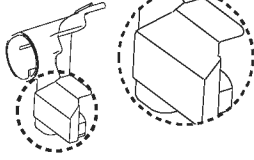
Etapa 24: Perfiles 814 deben ser insertados de las cuatro esquinas del invernadero, a continuación, inserte el perfil 815 entre ellos.

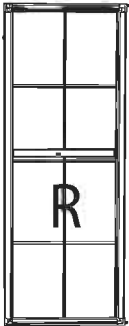
Etapa 25: Asegúrese de utilizar tornillos largos 450 para asegurar el retenedor de la puerta 363 que figura en la ilustración b. Apriete todos los tornillos de montaje al completar.

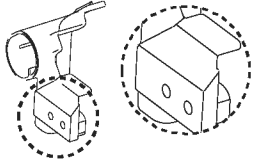





Contents



Item	cm/Inch	Qty.	Item	cm/Inch	Qty.	Item	cm/Inch	Qty.	Item	cm/Inch	Qty.	Item	cm/Inch	Qty.
 809	55.5cm/22"	x 1	 7020	25	x 1	 833	53cm/20 ³ / ₄ "	x 4	 840	199cm/78"	x 1	 846	57.5cm/22 ³ / ₄ "	x 1
 813	118cm/46 ¹ / ₂ "	x 4	 7021	26	x 1	 835	151.5cm/59 ³ / ₄ "	x 6	 841	199cm/78"	x 1	 847	151.5cm/59 ³ / ₄ "	x 4
 814	90cm/35 ¹ / ₂ "	x 4	 7022	7	x 1	 836	151.5cm/59 ³ / ₄ "	x 6	 842	115cm/45 ¹ / ₄ "	x 1	 848	151.5cm/59 ³ / ₄ "	x 2
 815	60cm/23 ¹ / ₂ "	x 2	 7023	26	x 1	 837	195cm/76 ³ / ₄ "	x 1	 843	115cm/45 ¹ / ₄ "	x 1	 849	151.5cm/59 ³ / ₄ "	x 2
 816	118cm/46 ¹ / ₂ "	x 2	 824	118cm/46 ¹ / ₂ "	x 3	 838	199cm/78"	x 1	 844	55.5cm/22"	x 2	 850	154cm/60 ¹ / ₂ "	x 4
 817	118cm/46 ¹ / ₂ "	x 3	 256	115cm	x 8	 839	199cm/78"	x 1	 845	119cm/4 ¹ / ₂ "	x 1	 851	116cm/45 ¹ / ₂ "	x 1

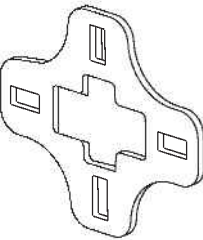

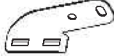
Contents

Item	cm/Inc	Qty.	Item	cm/Inc	Qty.	Item	Qty.	Item	Qty.	Item	Qty.
 852	56cm/22"	x 2	 561		x 2	 34	x 1	 422	spare x 16	 28	x 5
 855	57.5cm/22 ³ / ₄ "	x 1	 566		x 21	 46	x 2	 465	spare x 16 x 1	 29A	x 2
 558		x 1	 563		x 1	 47	x 2	 464	x 8	 29B	x 3
 560		x 2	 99		x 1	 48	x 2	 462	x 4	 565	x 1
 559		x 2	 100		x 1	 49A	x 1	 466	spare x 90 x 2	 564	
 562		x 2	 300 140cm		x 2	 49B	x 1	 411	spare x 24 x 2		
			 101 90cm		x 1	 363	x 1	 447 16mm	spare x 6 x 1		
						 450 32mm	x 2 spare x 1	 461	spare x 64 x 2		

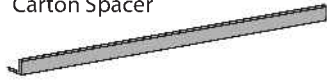

Contents

Item		Qty.
927		x 2
459		x 3
460		x 6
98B		x 2
853	 199.5m/78 1/2"	x 2
456		x 2
926		x 2
924		x10

Item		Qty.
21	 spare	x 4 x 1
23	 spare	x 9 x 2
22	 spare	x 14 x 1

Carton Spacer		
95	56.5cm/22 1/2"	x 1
40		x 1

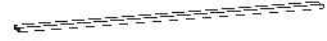
spare parts

Item		Qty.
		
		x 1
#4		x 1

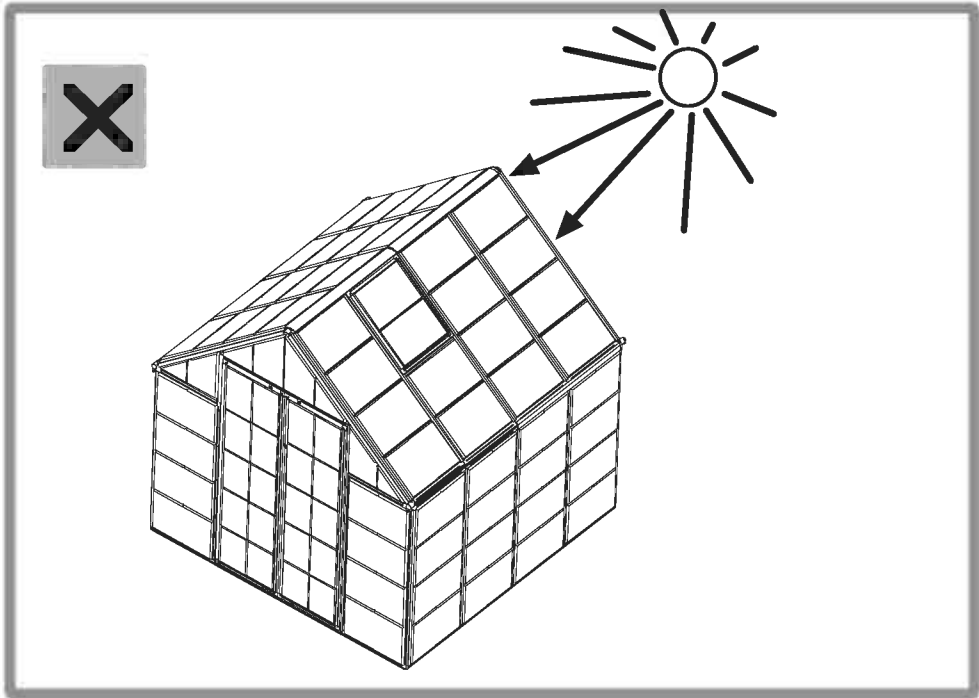
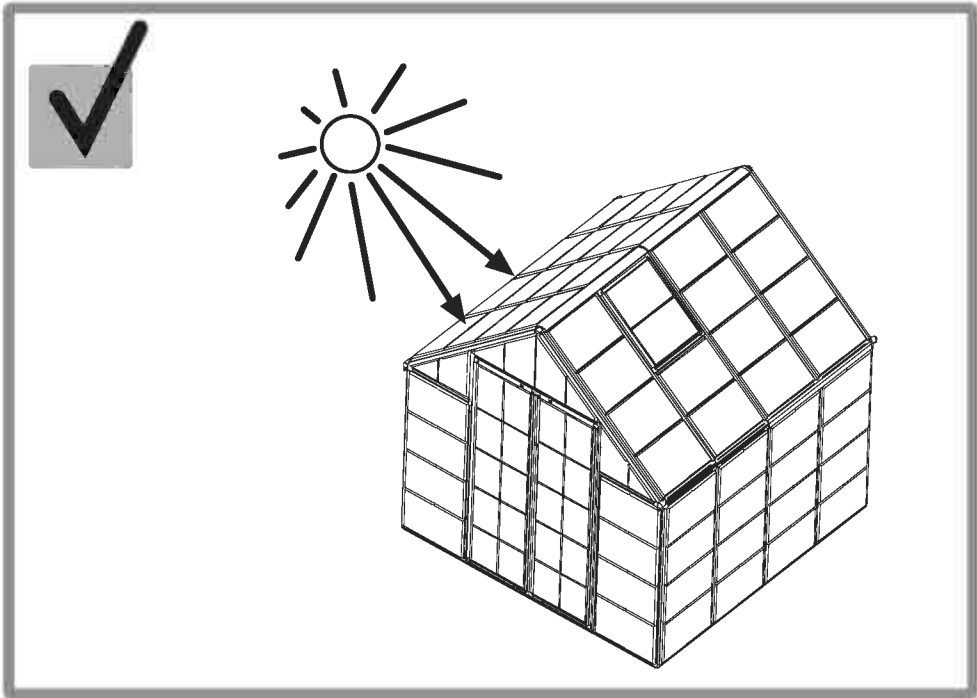
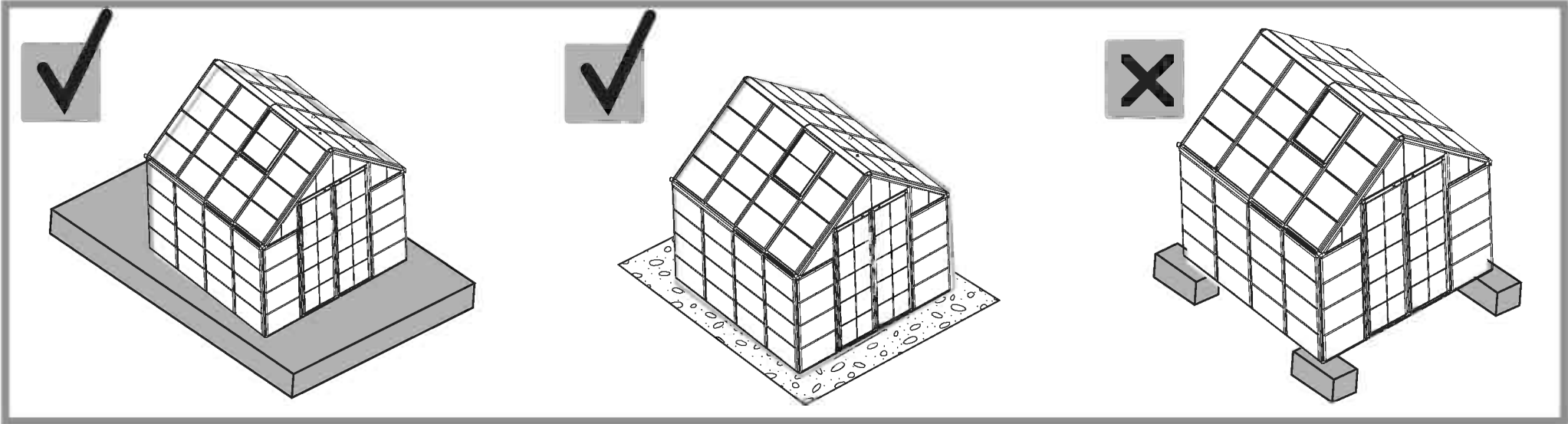

845 x 1



846 x 1

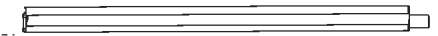

817 x 3

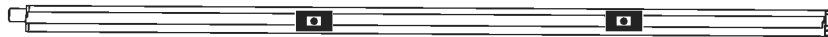

855 x 1

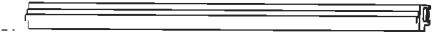

824 x 3



47 x 4



1

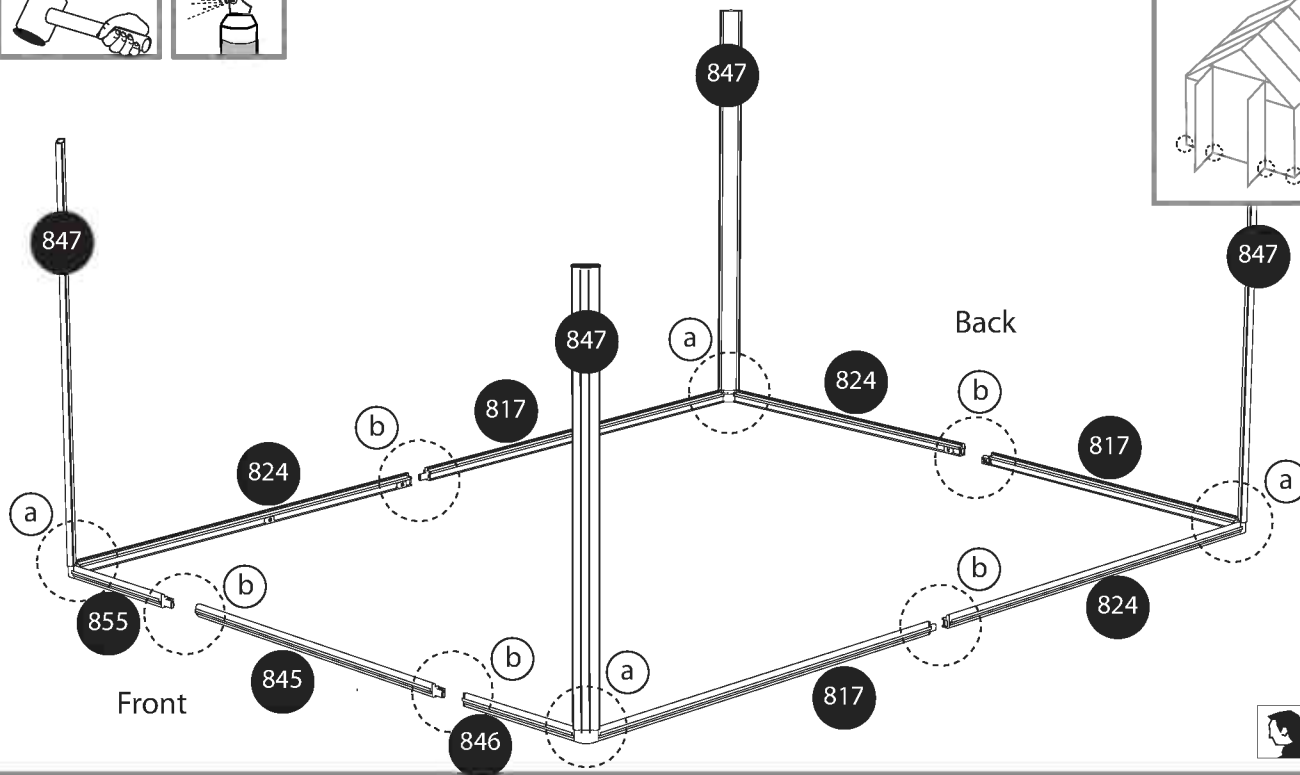

X2

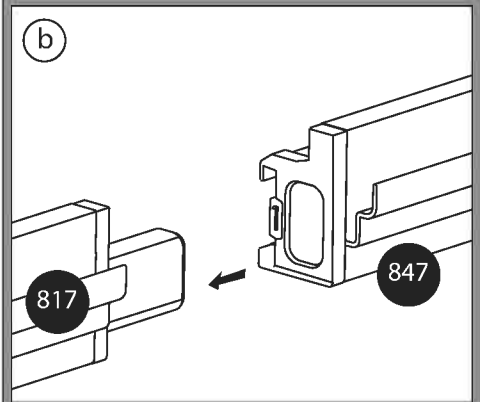
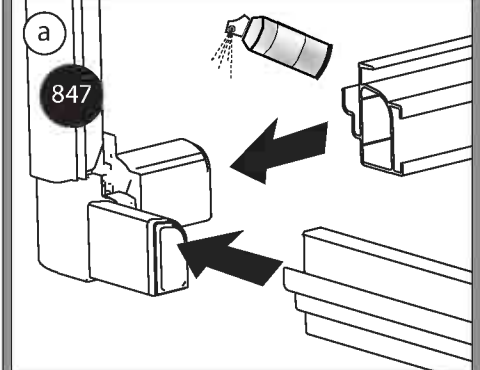

924

x 10



2

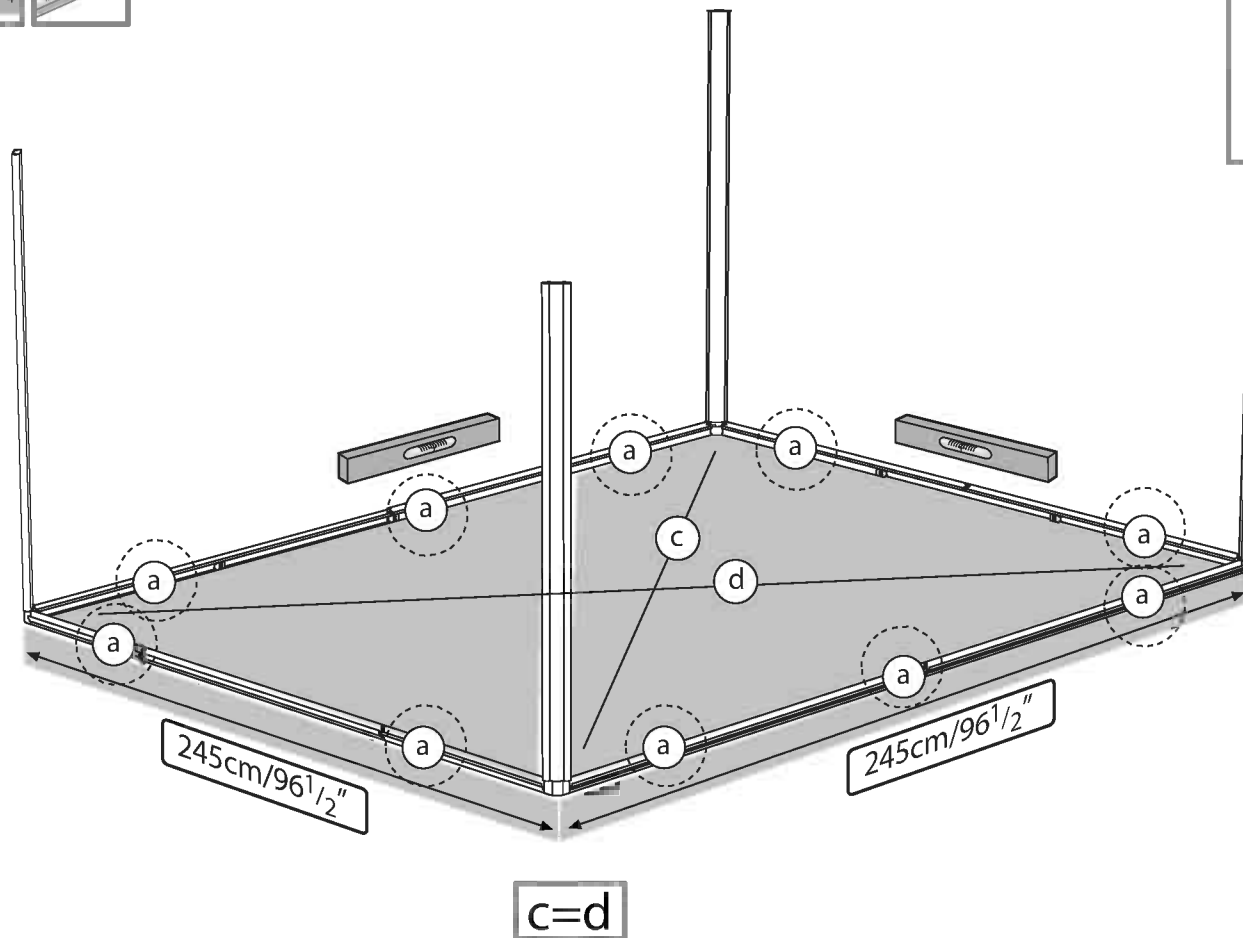
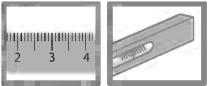

a

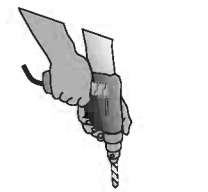

924

02 x 1



02 x 1



021 x 1



02 x 1



3

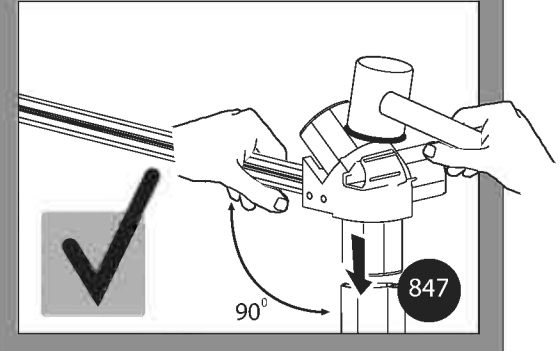
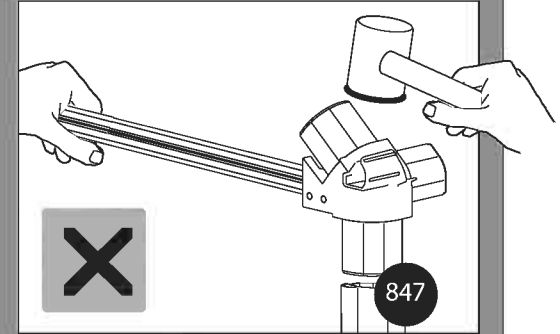
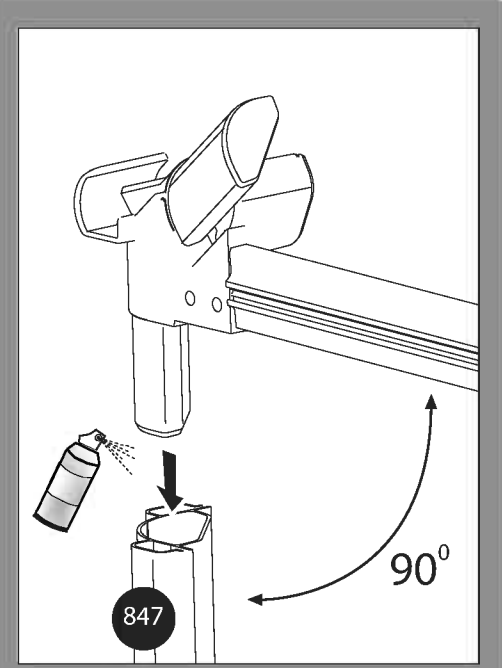
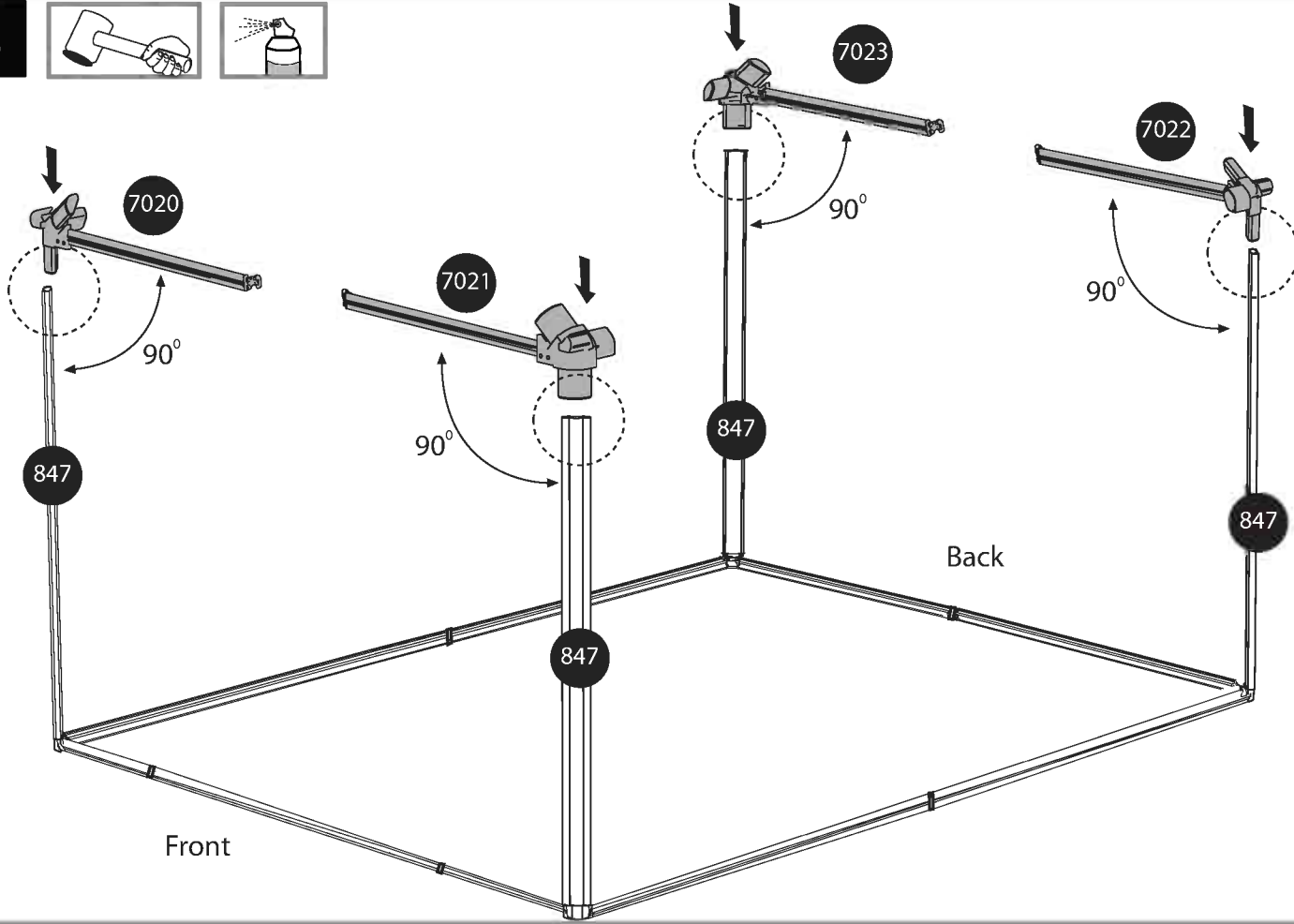
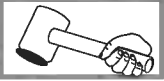

848 x 2



849 x 2

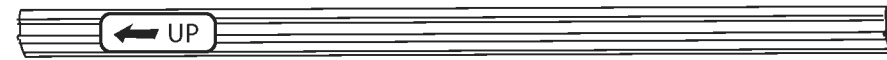

4

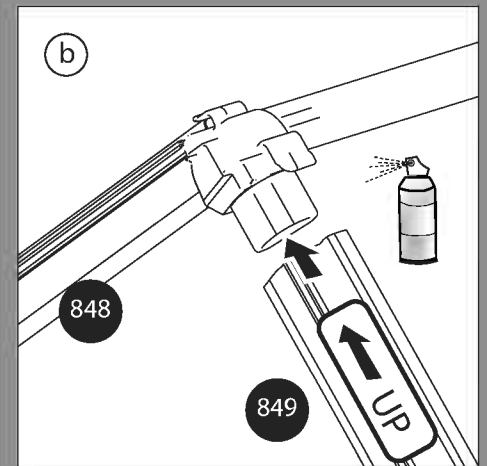
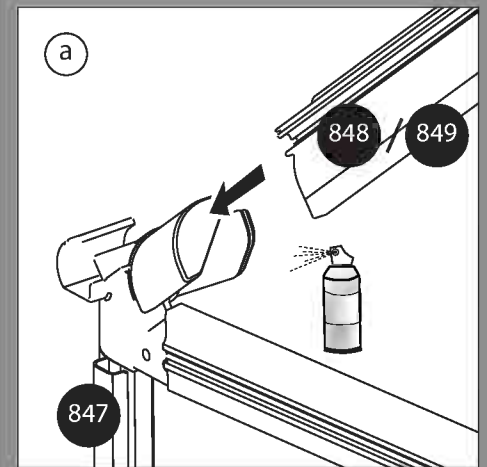
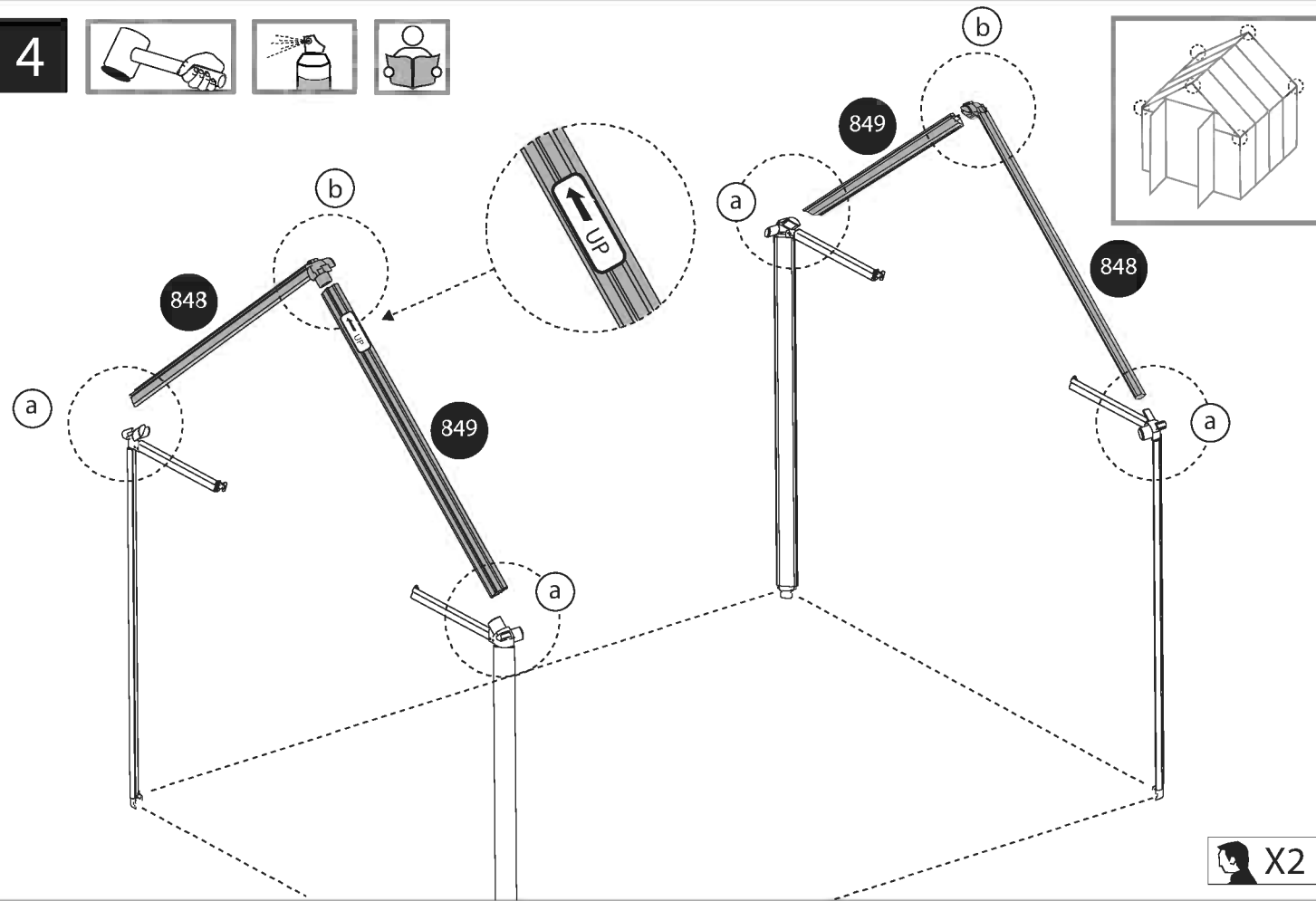

816 x 2



100 x 1

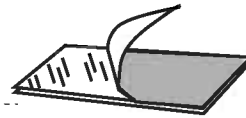

5

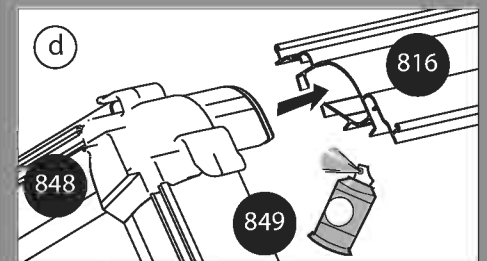
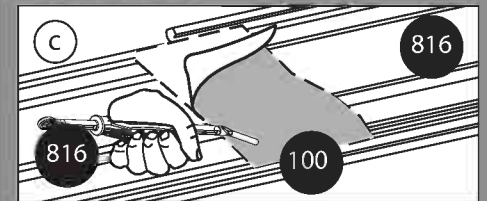
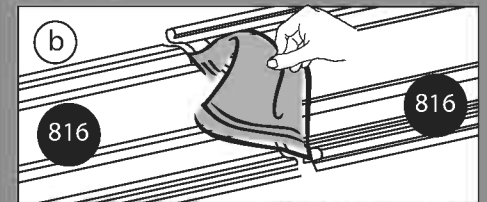
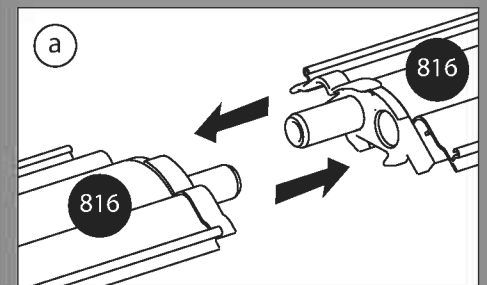
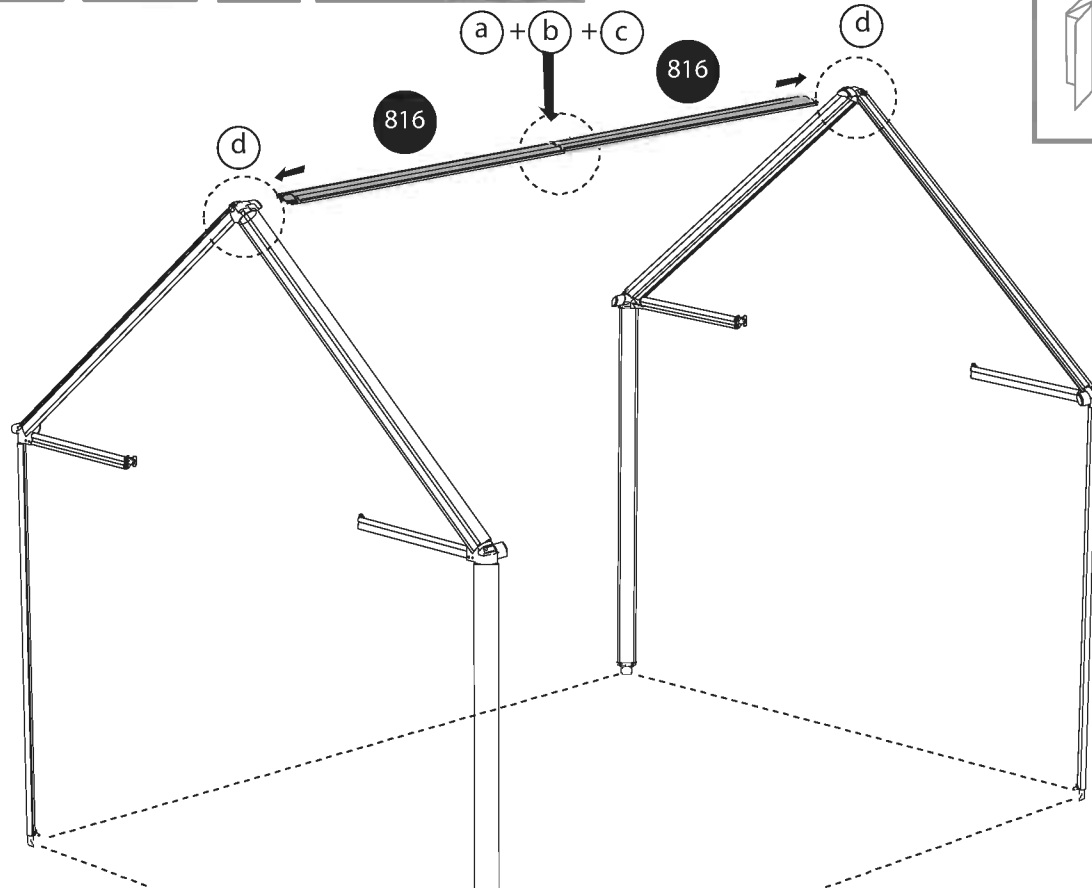
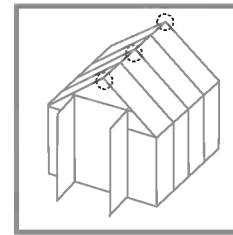

813

x 4



6

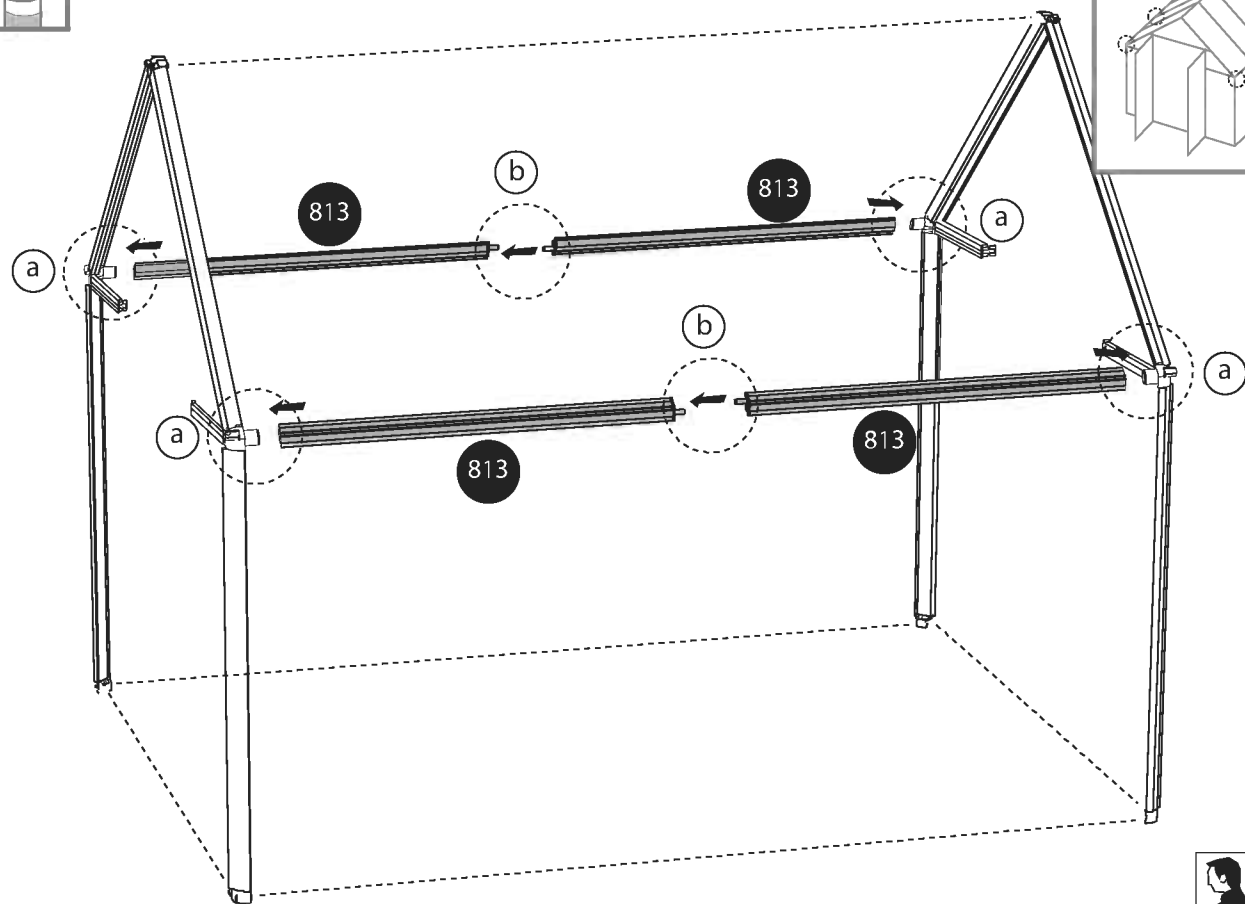

X2

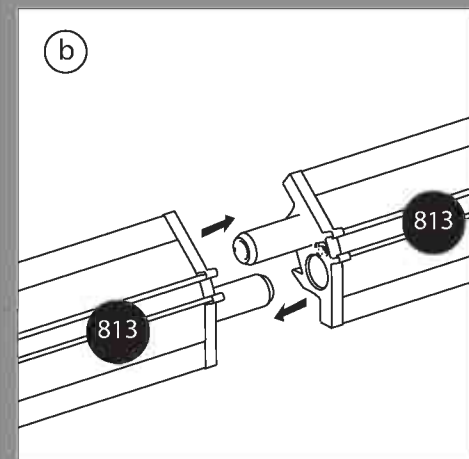
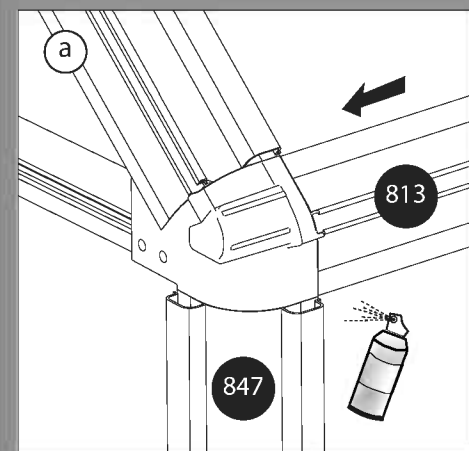

836

x 2

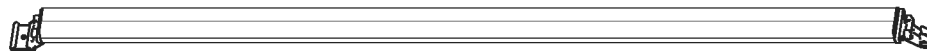

7

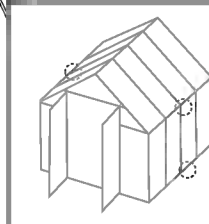
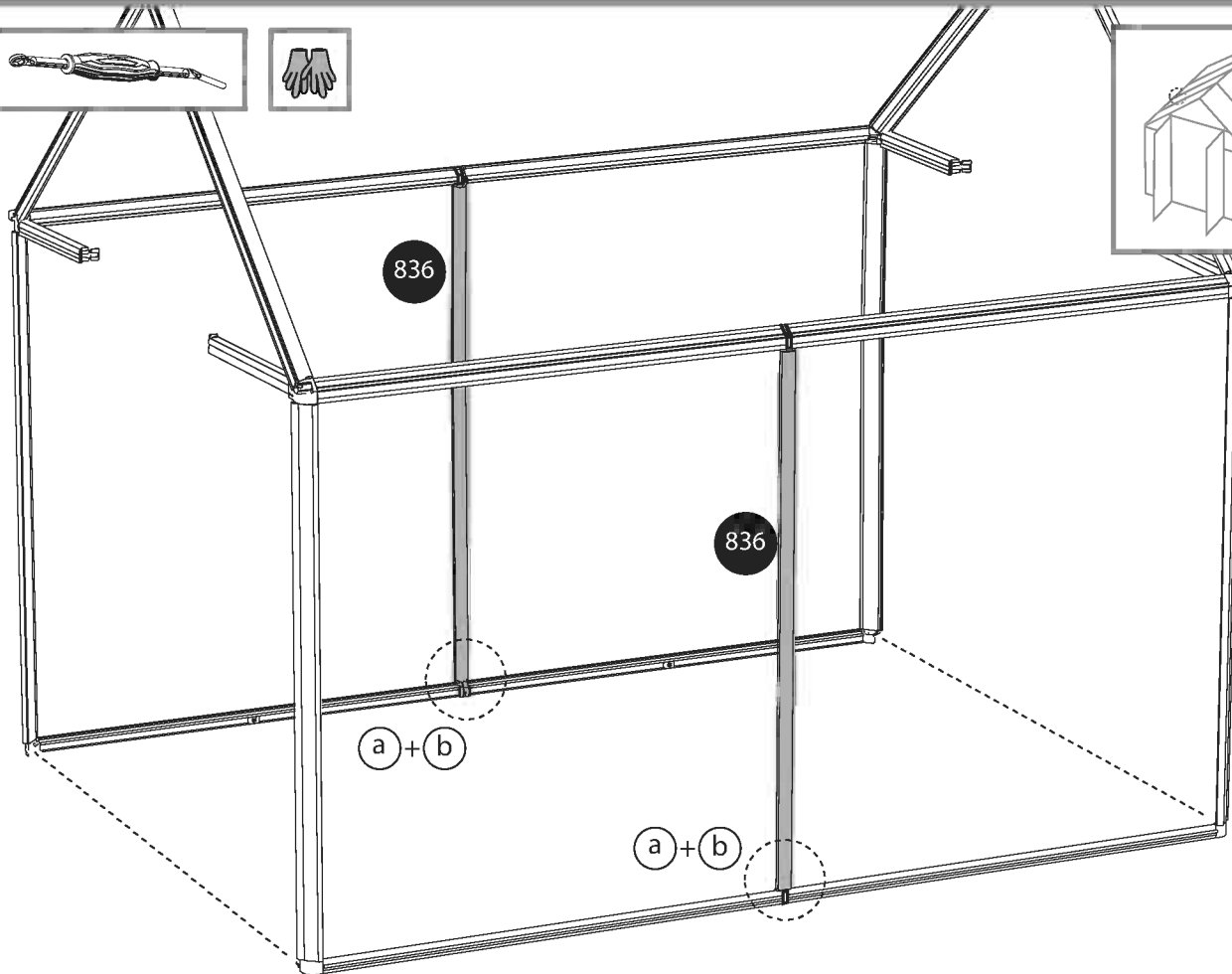

a

1

836

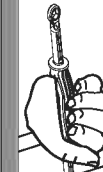

2



836

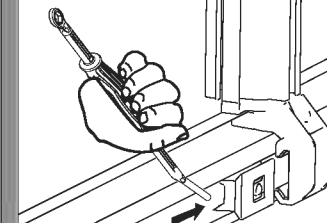

b

836

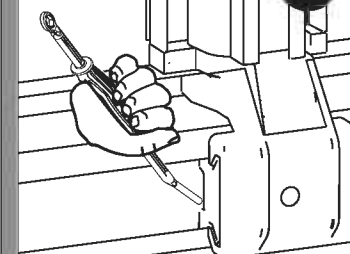

835 x 2

23 x 3

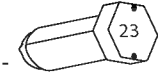
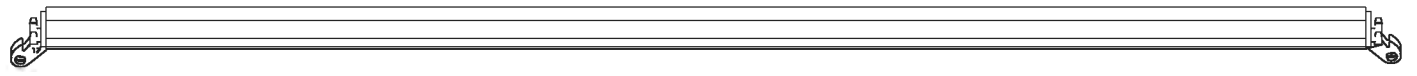

8

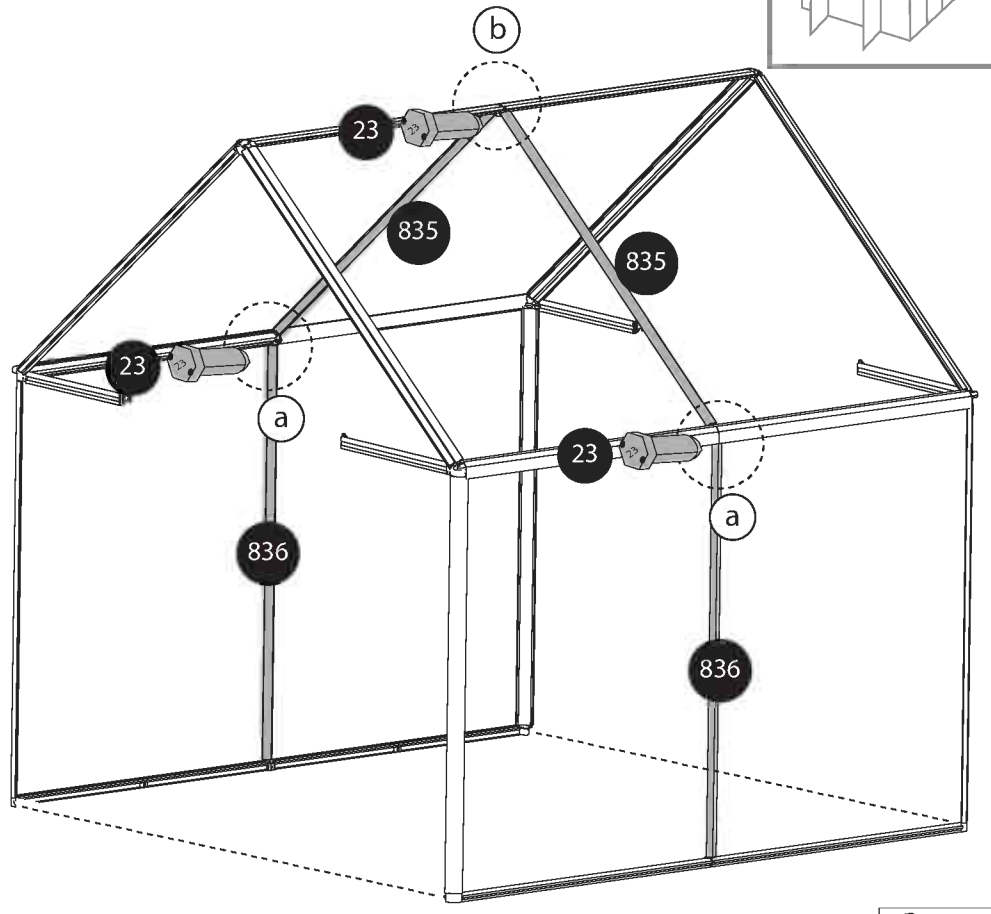
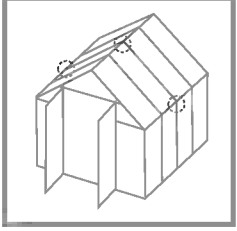

X2

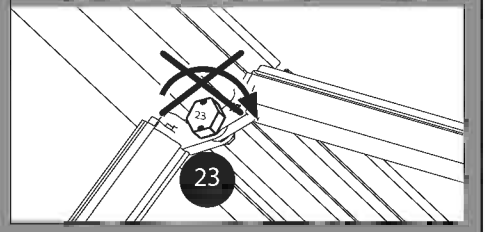
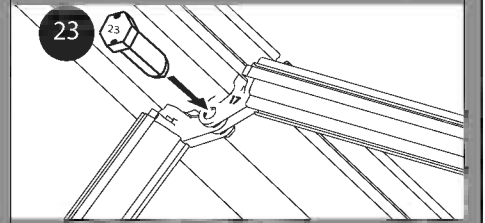
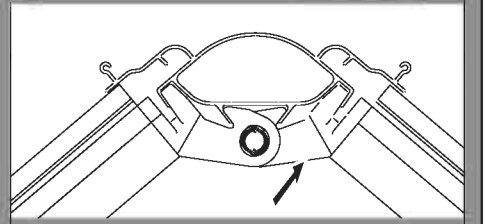
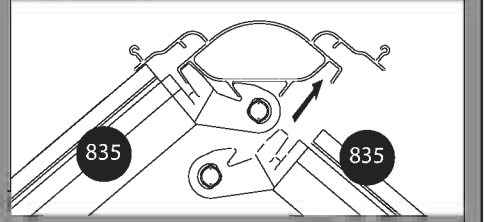
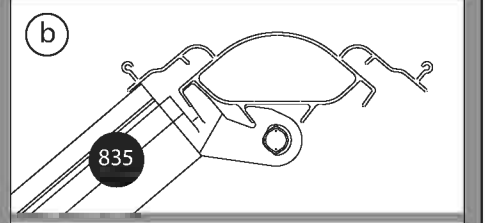
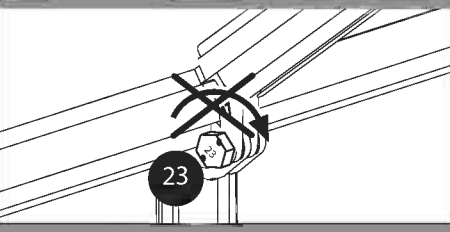
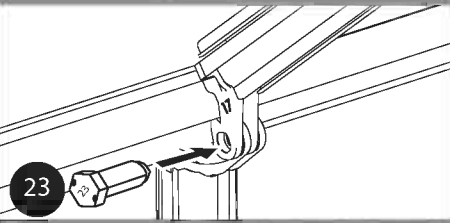
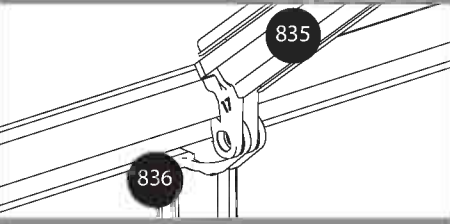
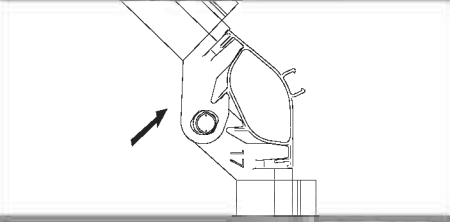
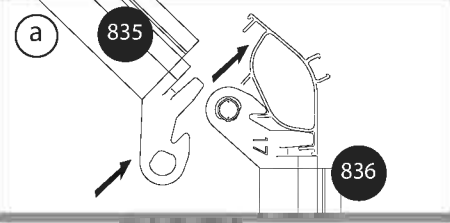

836 x 4

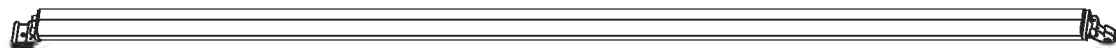

835 x 4

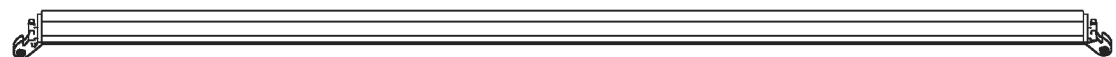

23 x 6



9

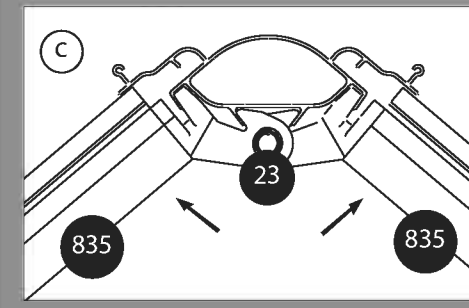
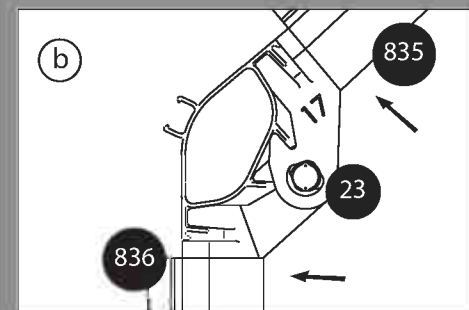
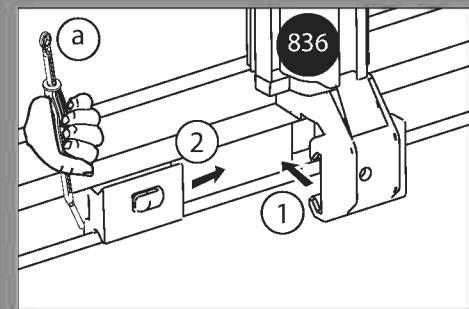
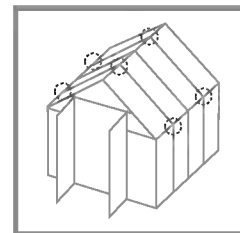
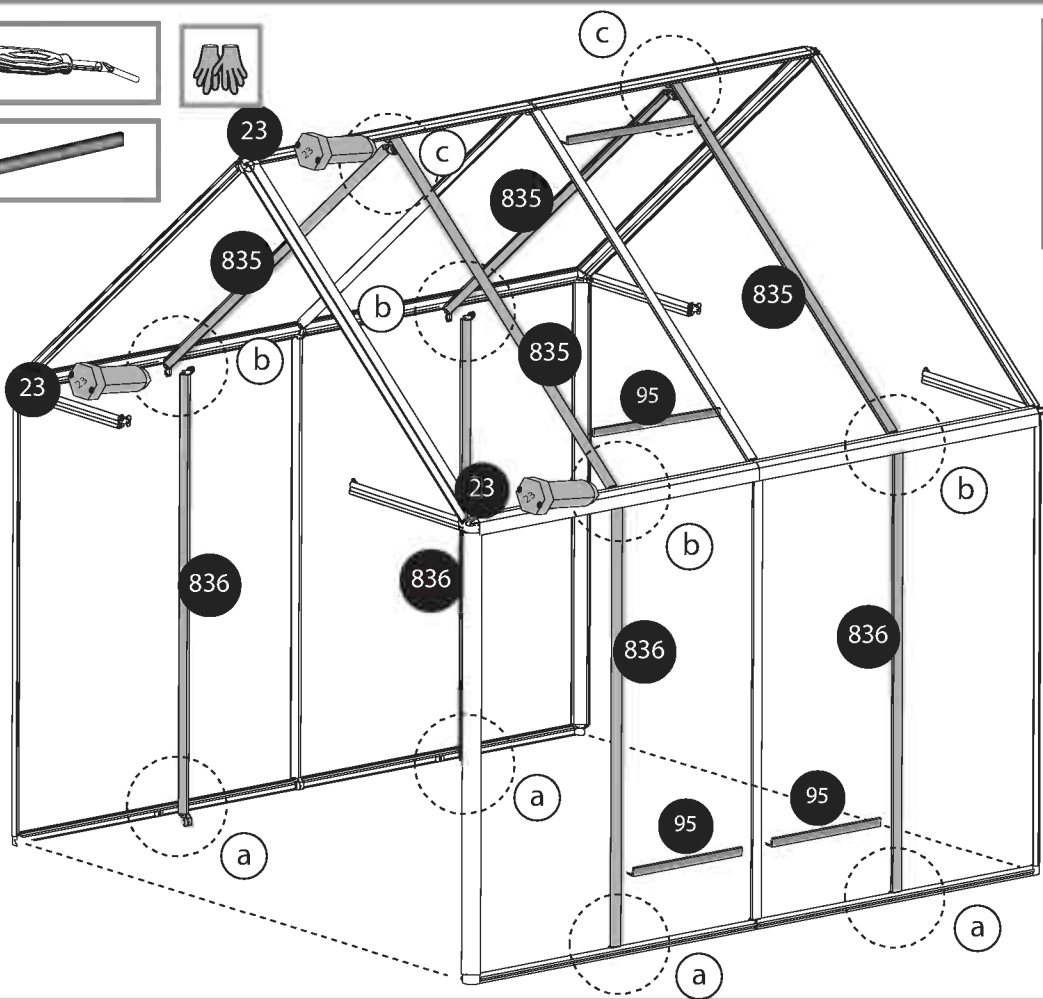
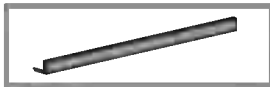
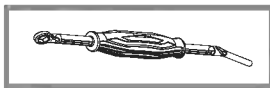

10



Carton Spacer



95

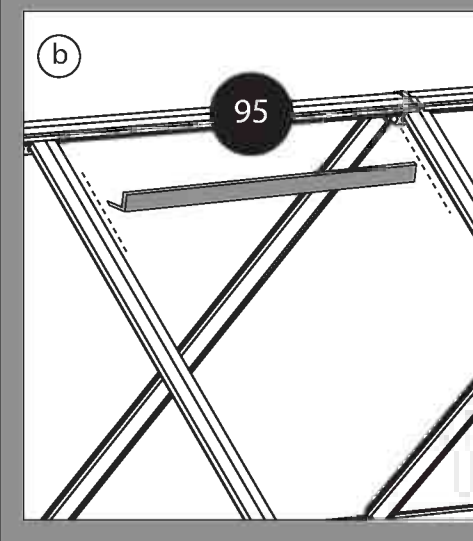
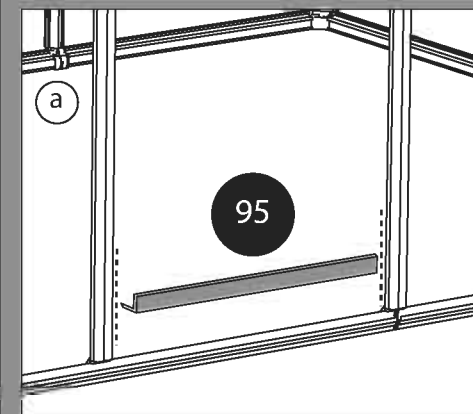
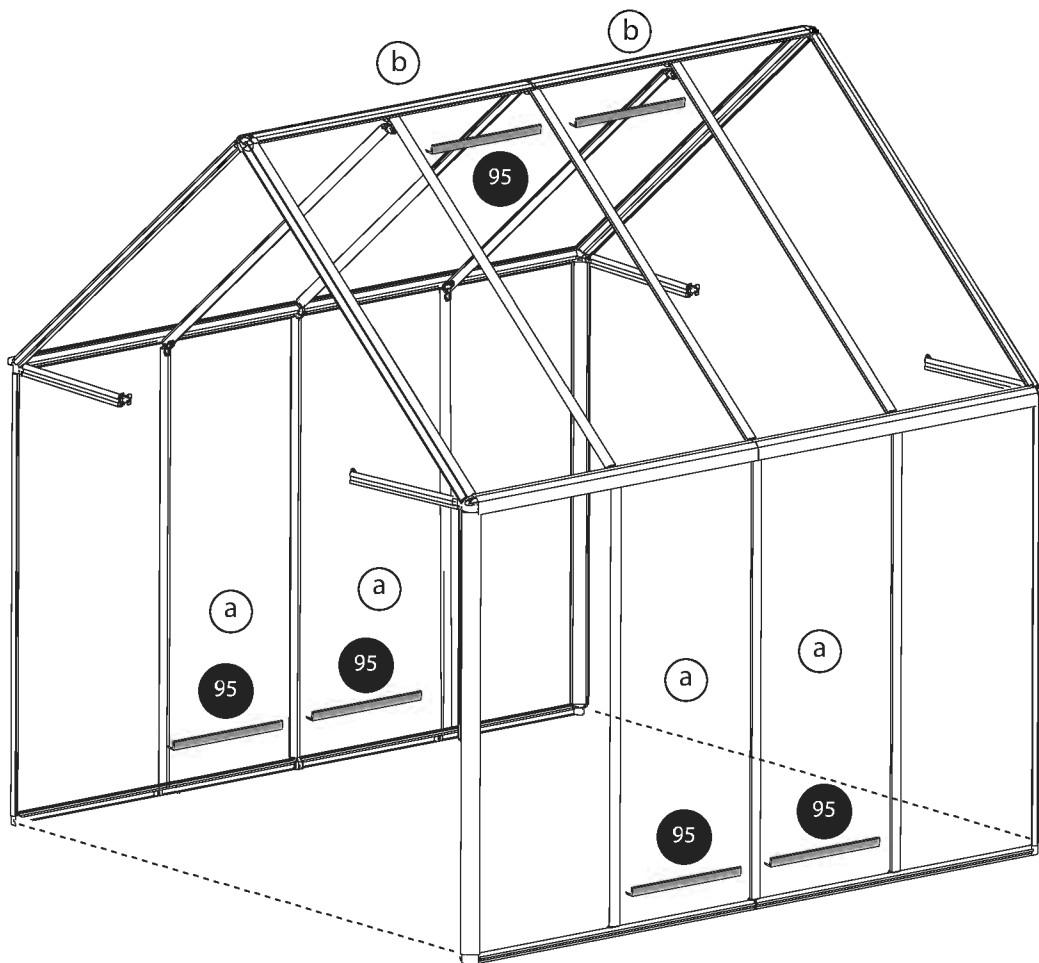
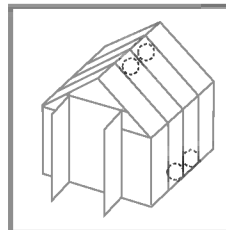

841 x 1

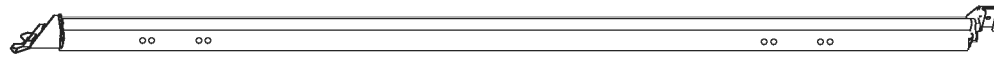

840 x 1



838 x 1



839 x 1

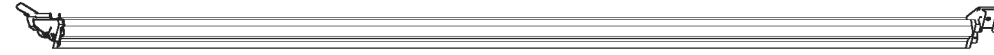

21 x 4

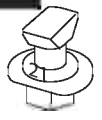

11

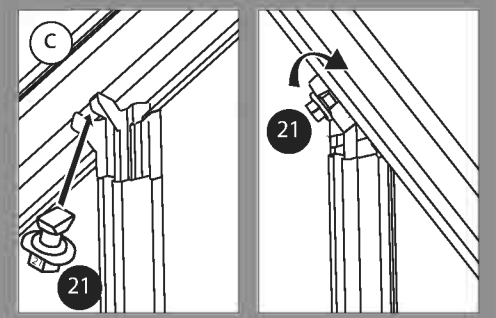
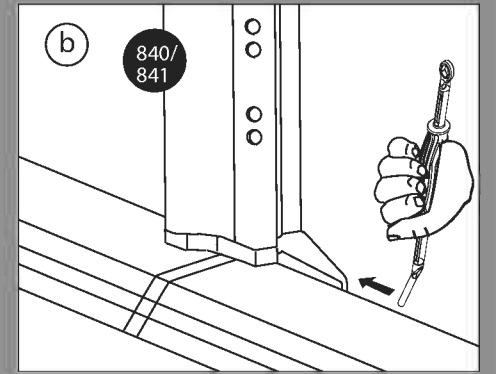
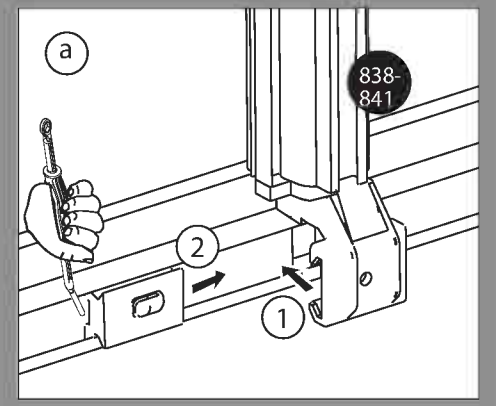
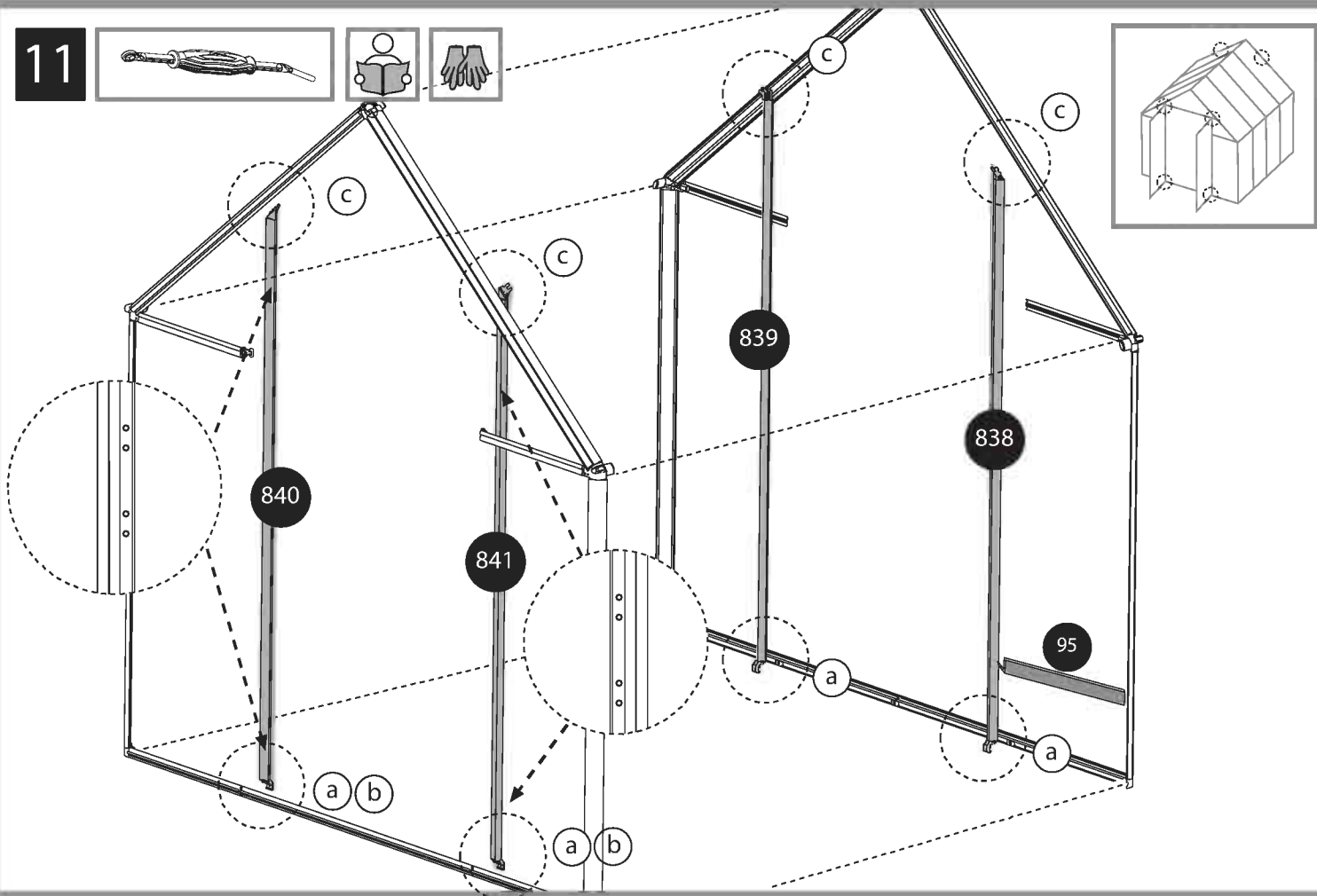

566

x 4

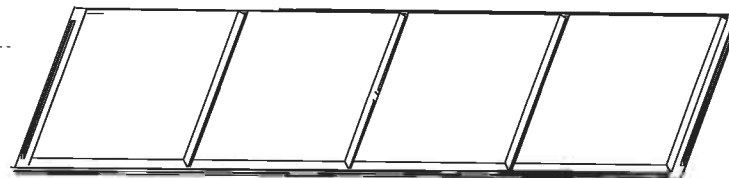

12

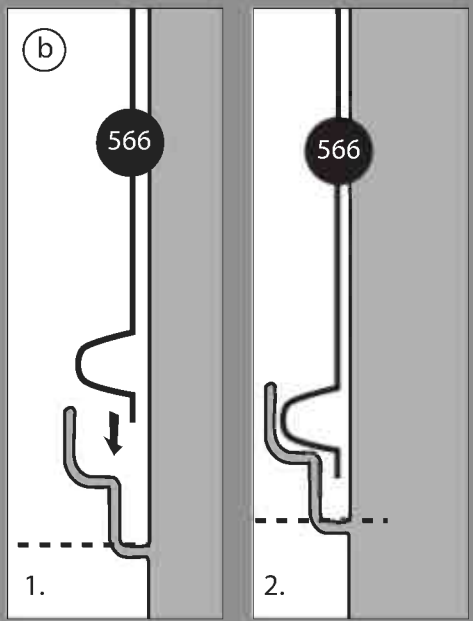
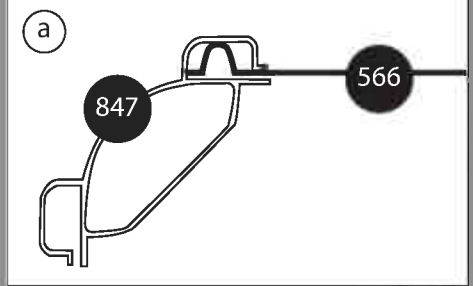
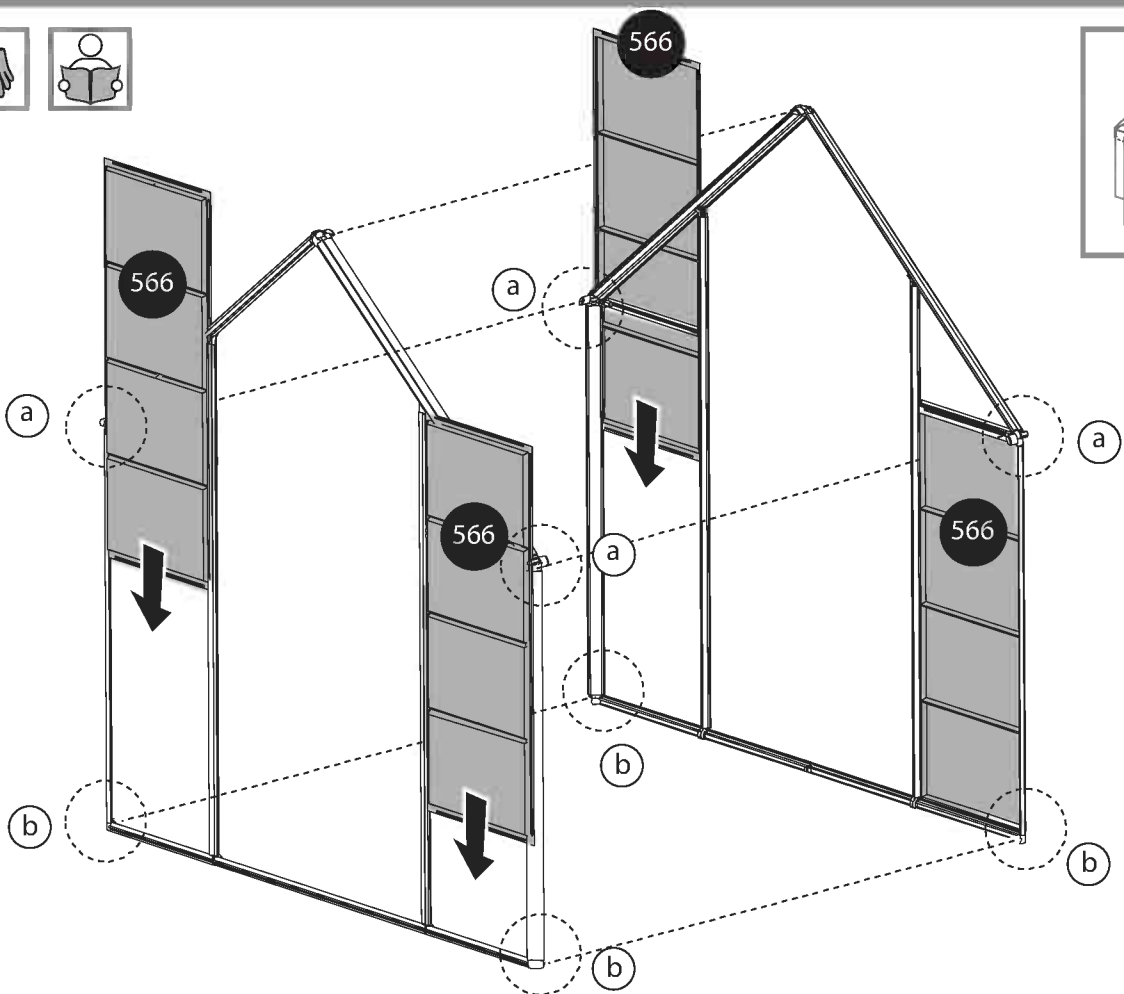

837

x 1

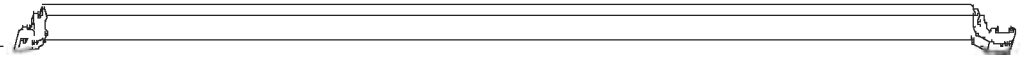

566

x 2

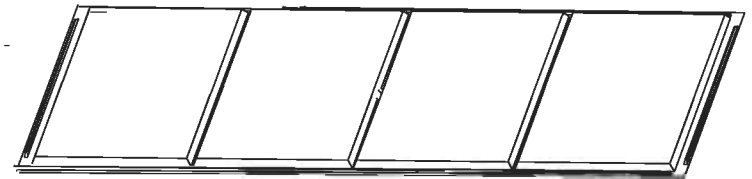

13

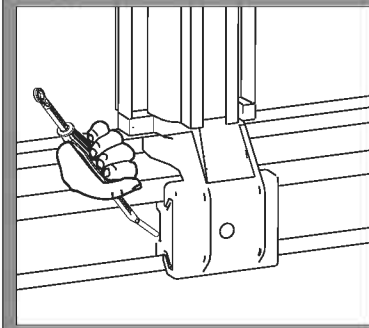
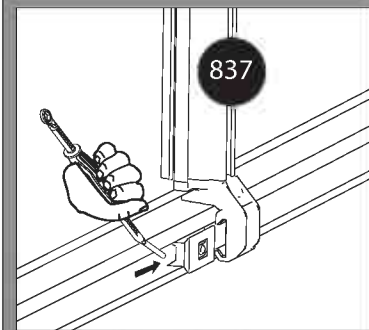
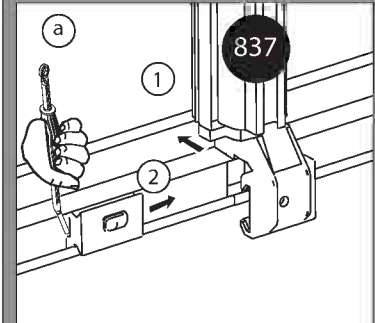
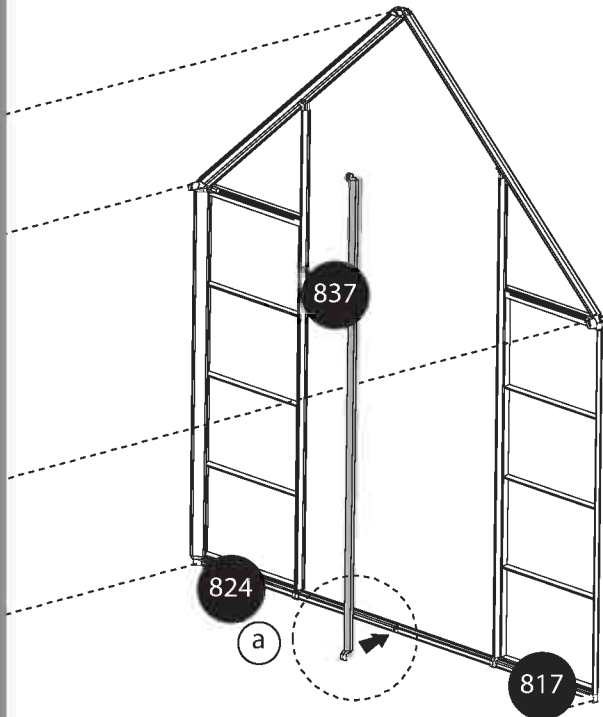

14

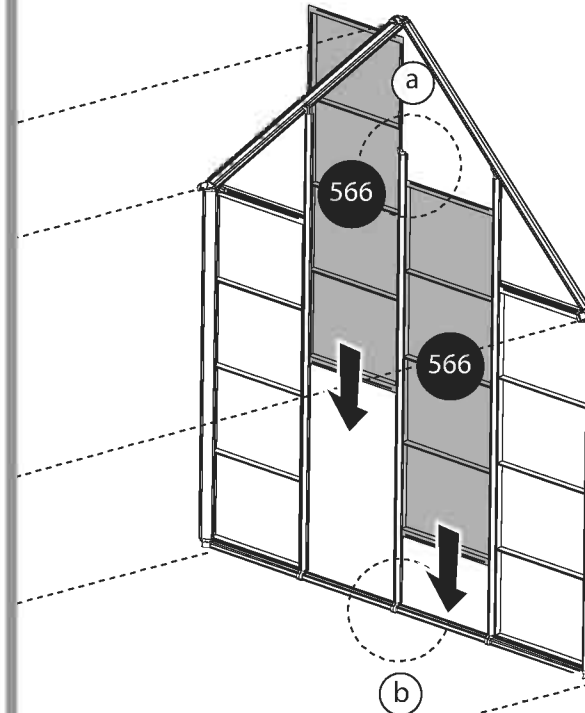
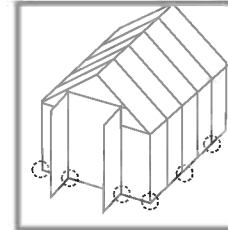

a

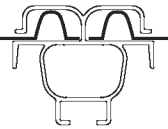

b

1.

2.

844 x 2

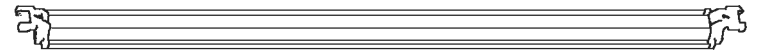

22 x 5

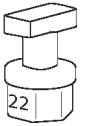

15

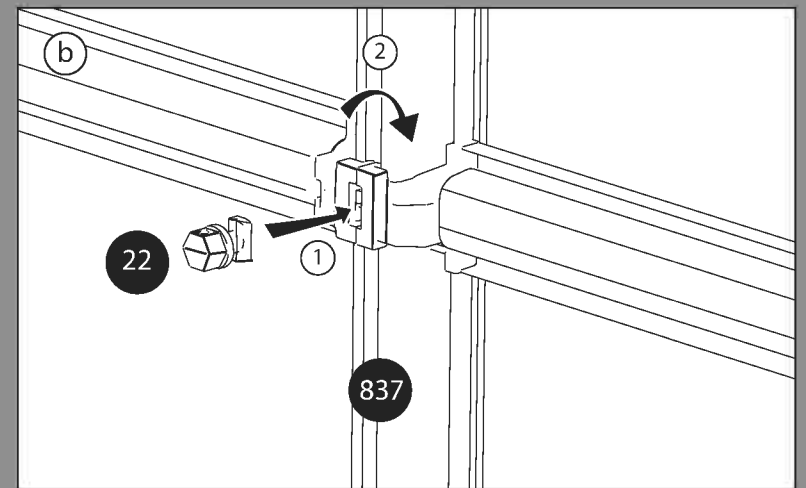
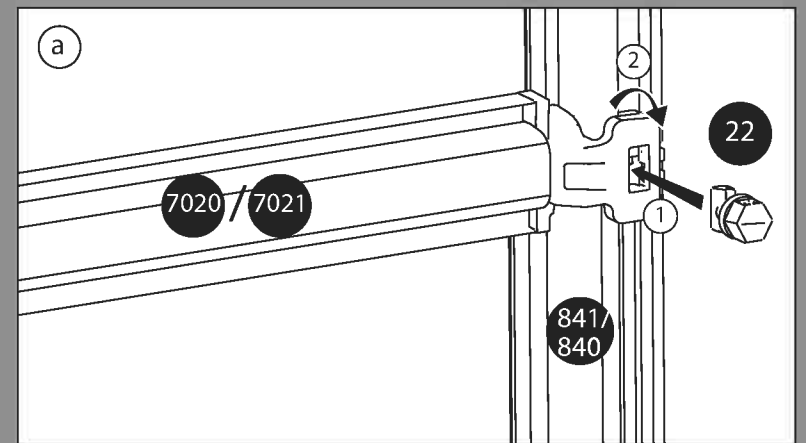
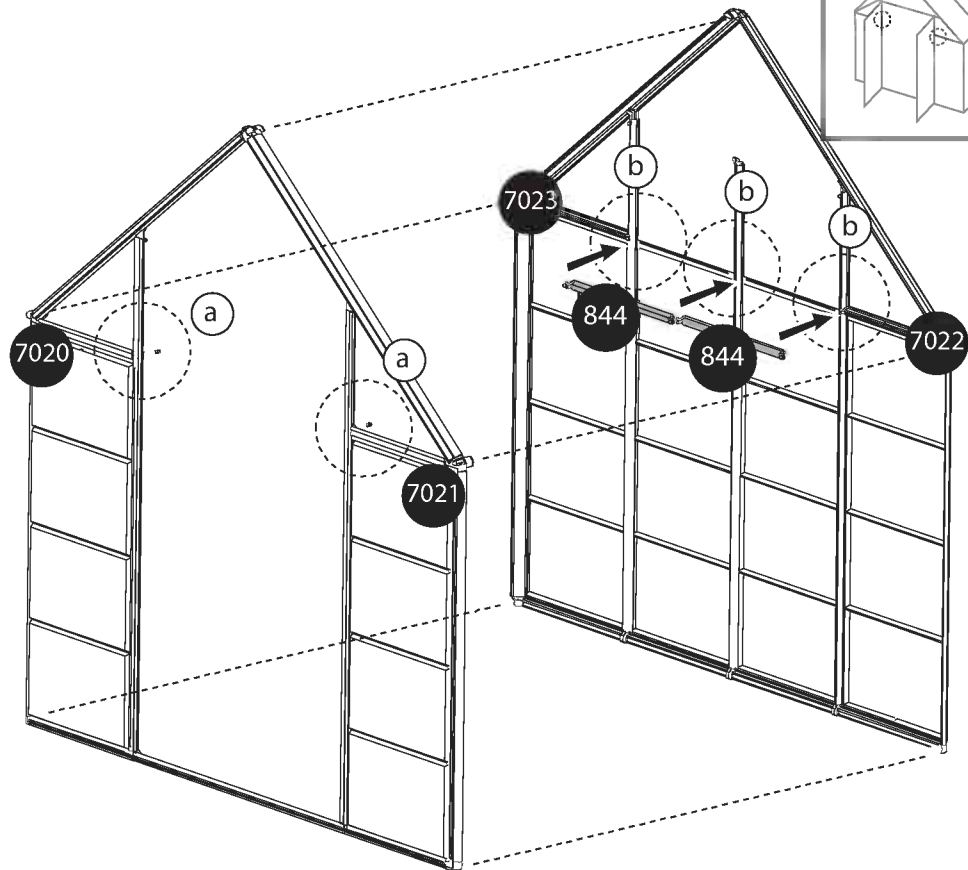
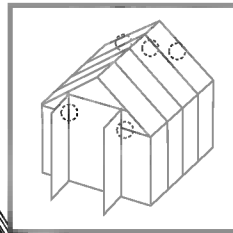

559 x 2

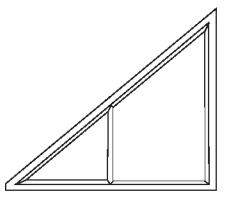

560 x 2

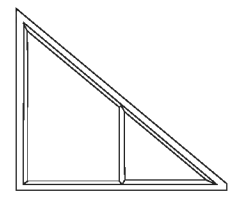

562 x 2

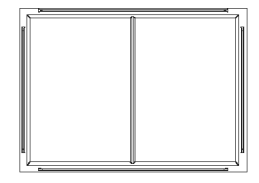

16 

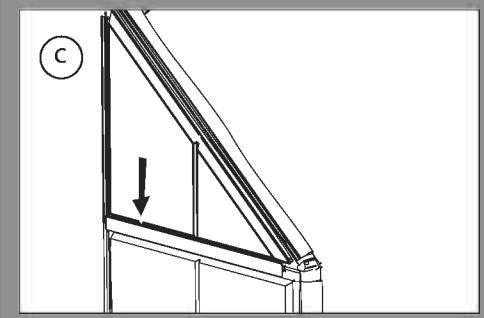
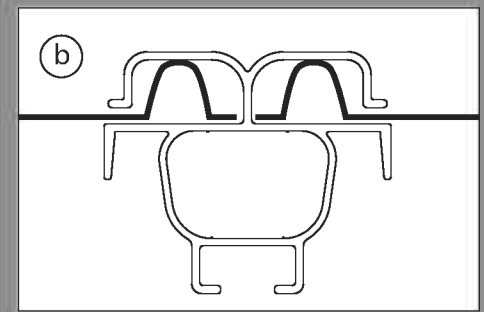
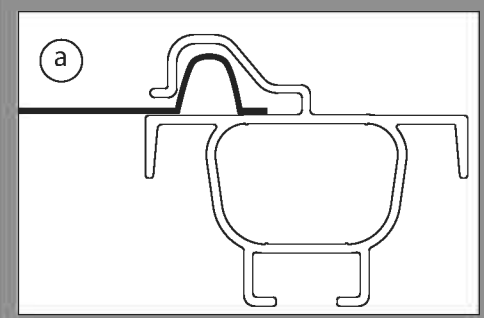
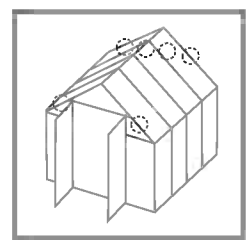
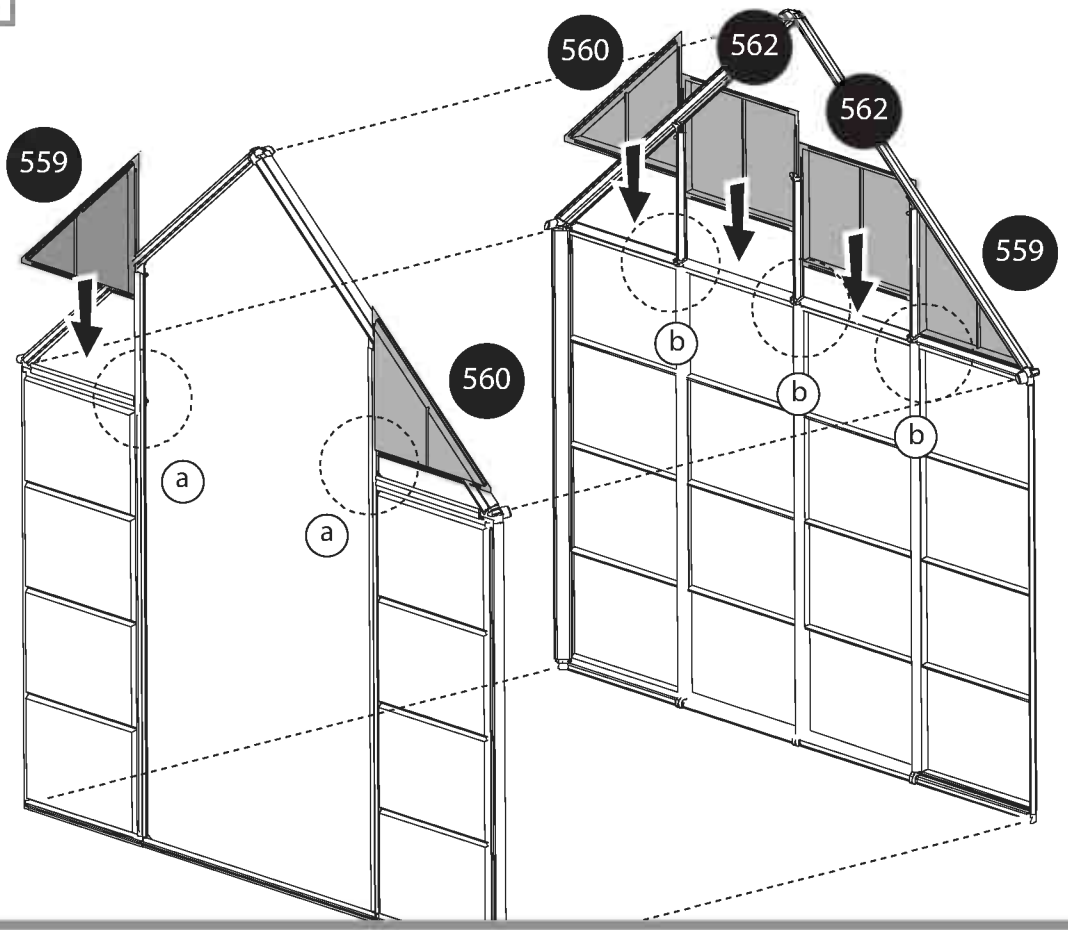

842 x 1

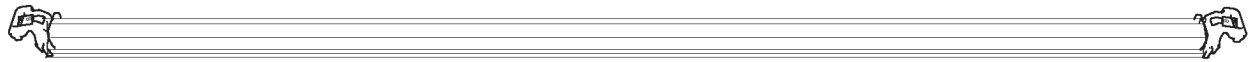

843 x 1

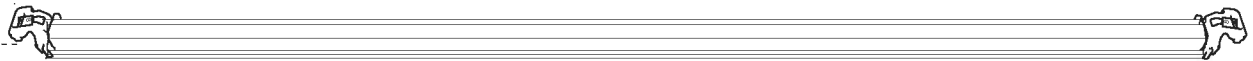

22 x 5

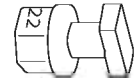

17

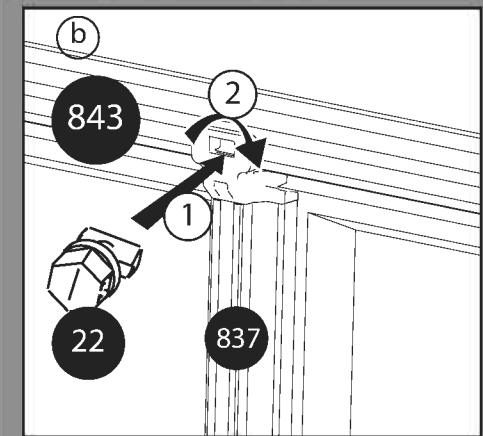
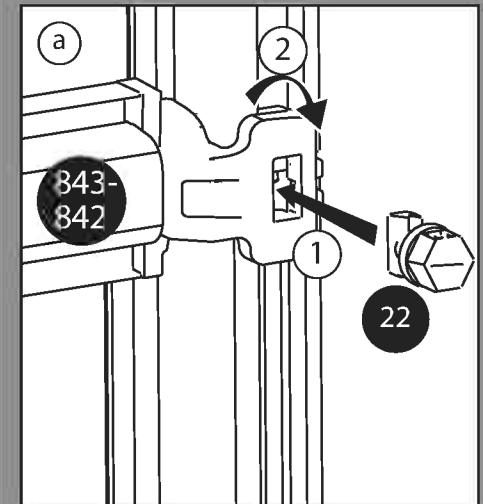
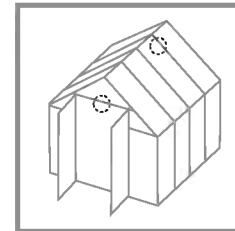
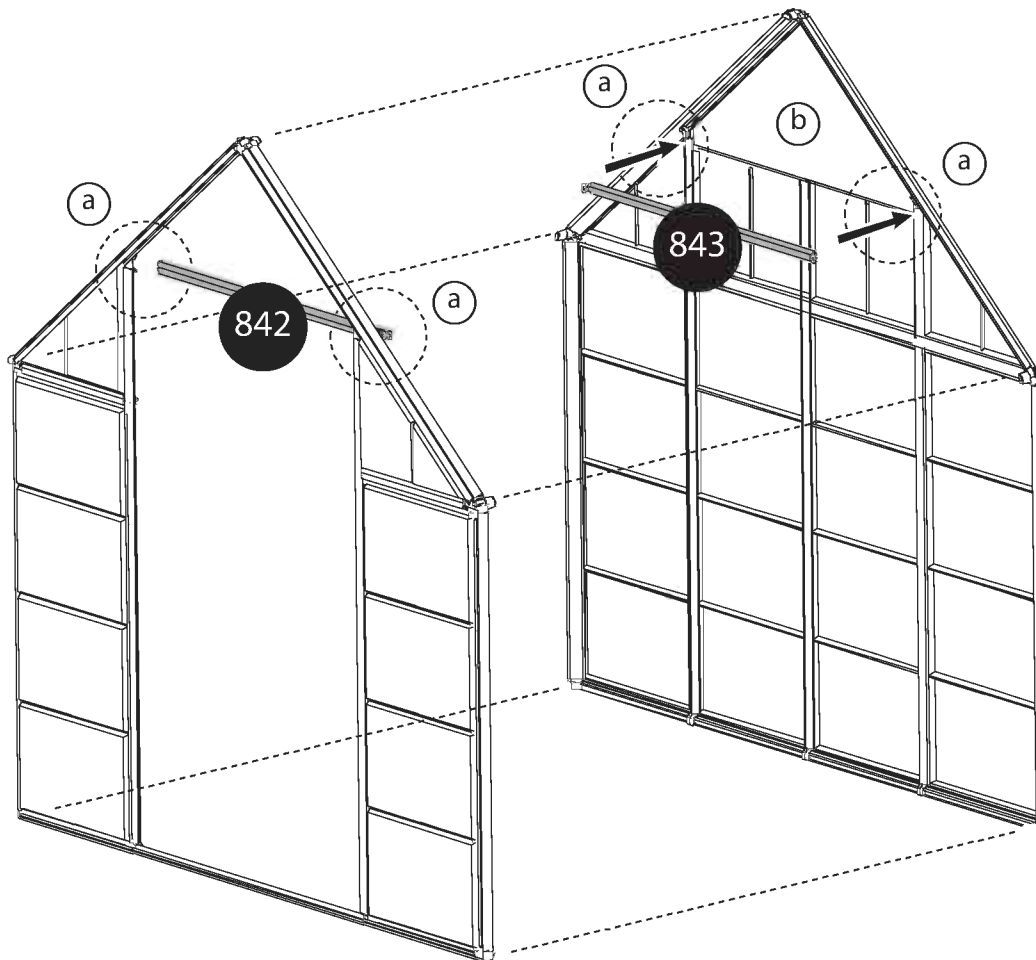

561 x 2

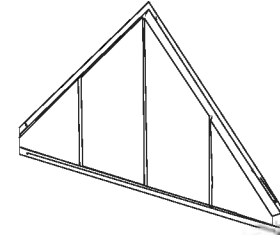

850 x 4

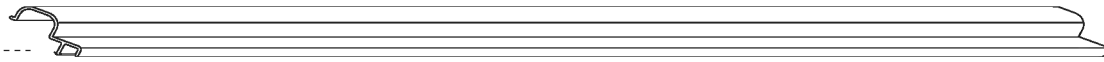

18

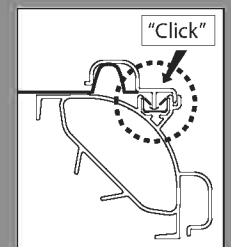
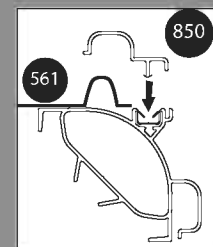
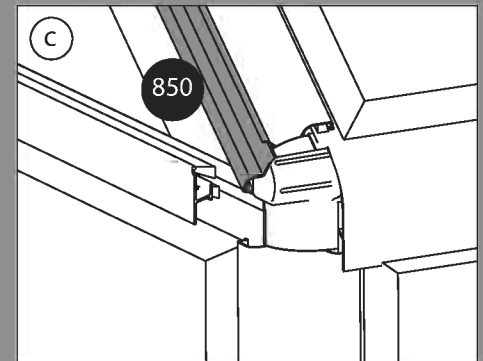
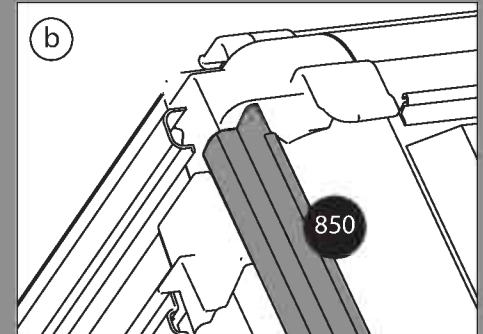
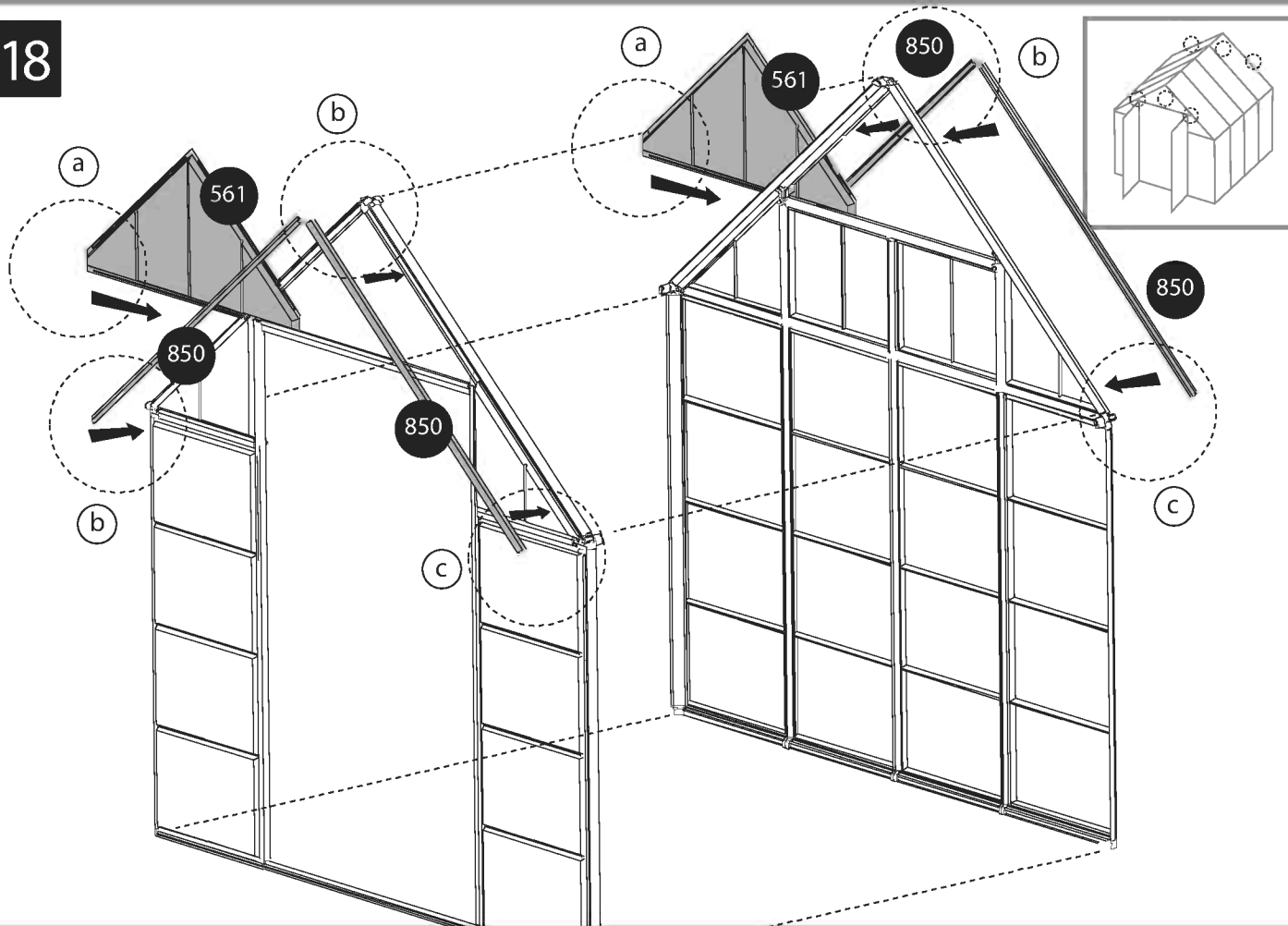

809 x 1

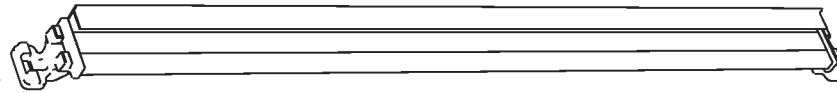

22 x 2



558 x 1

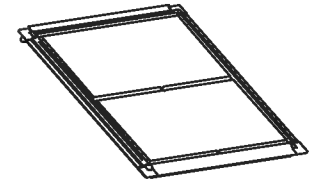

19

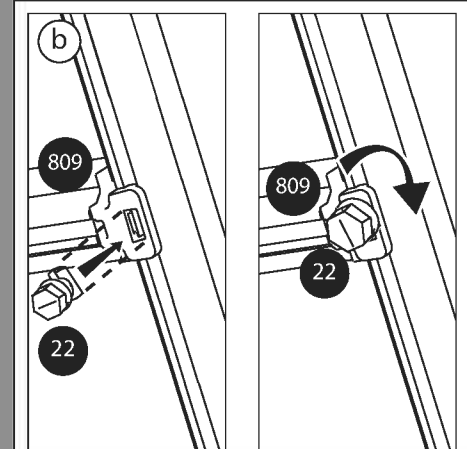
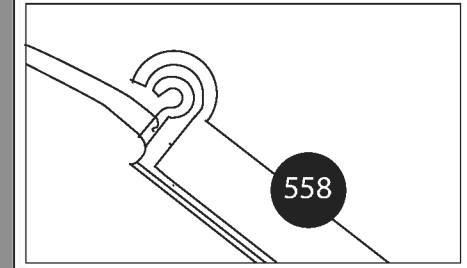
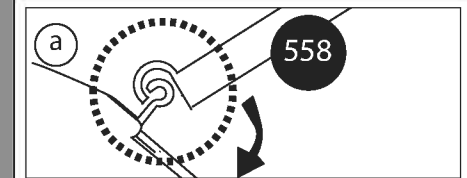
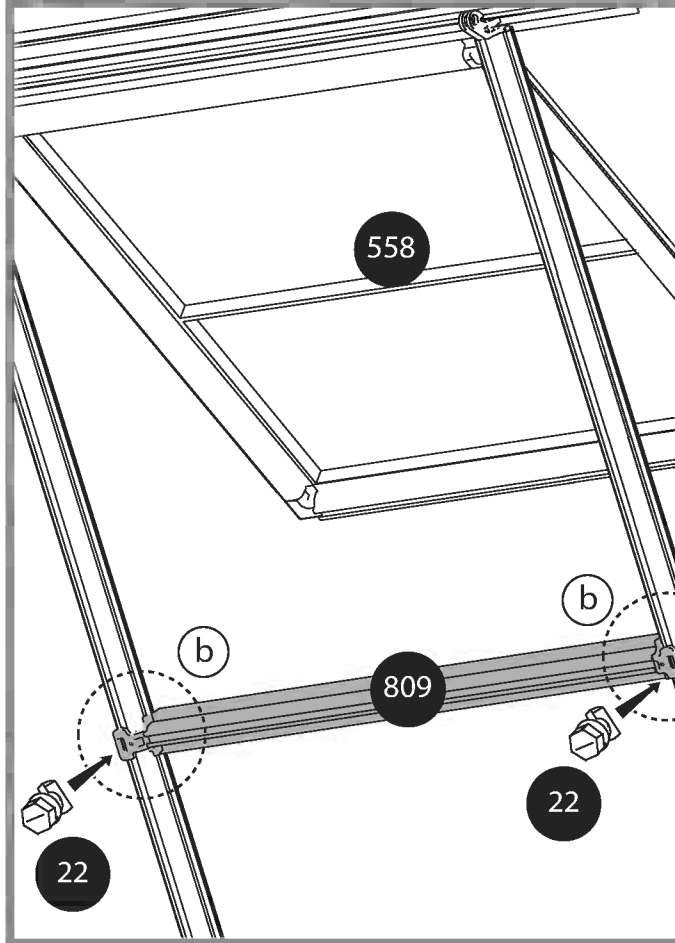
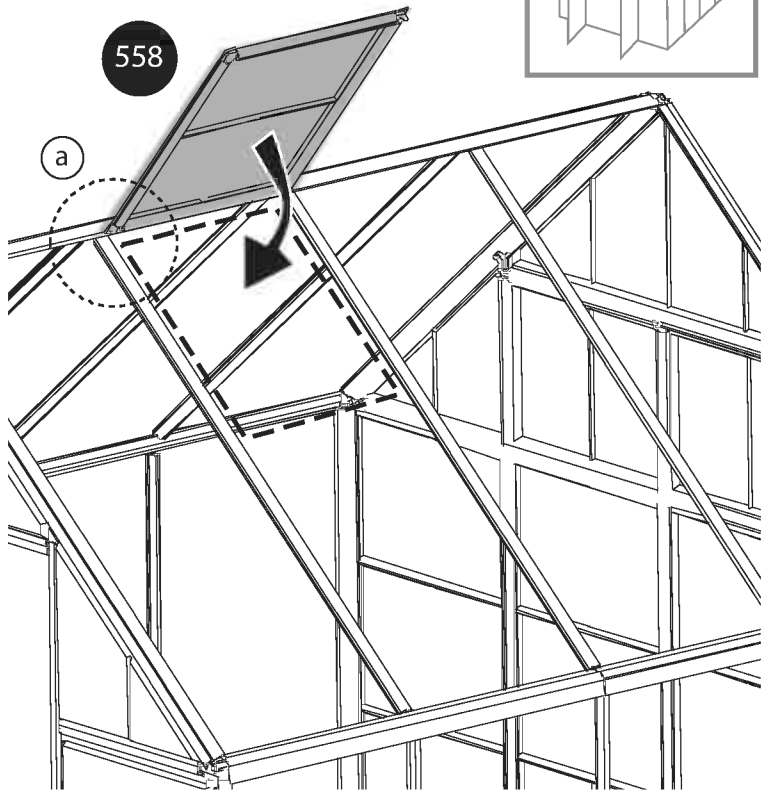
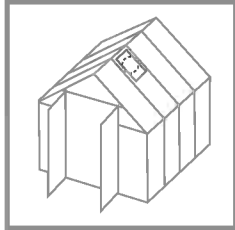

99

x 1

22

x 2

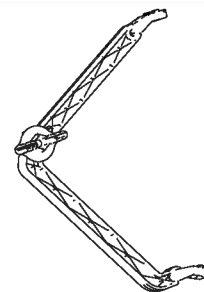
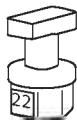

20

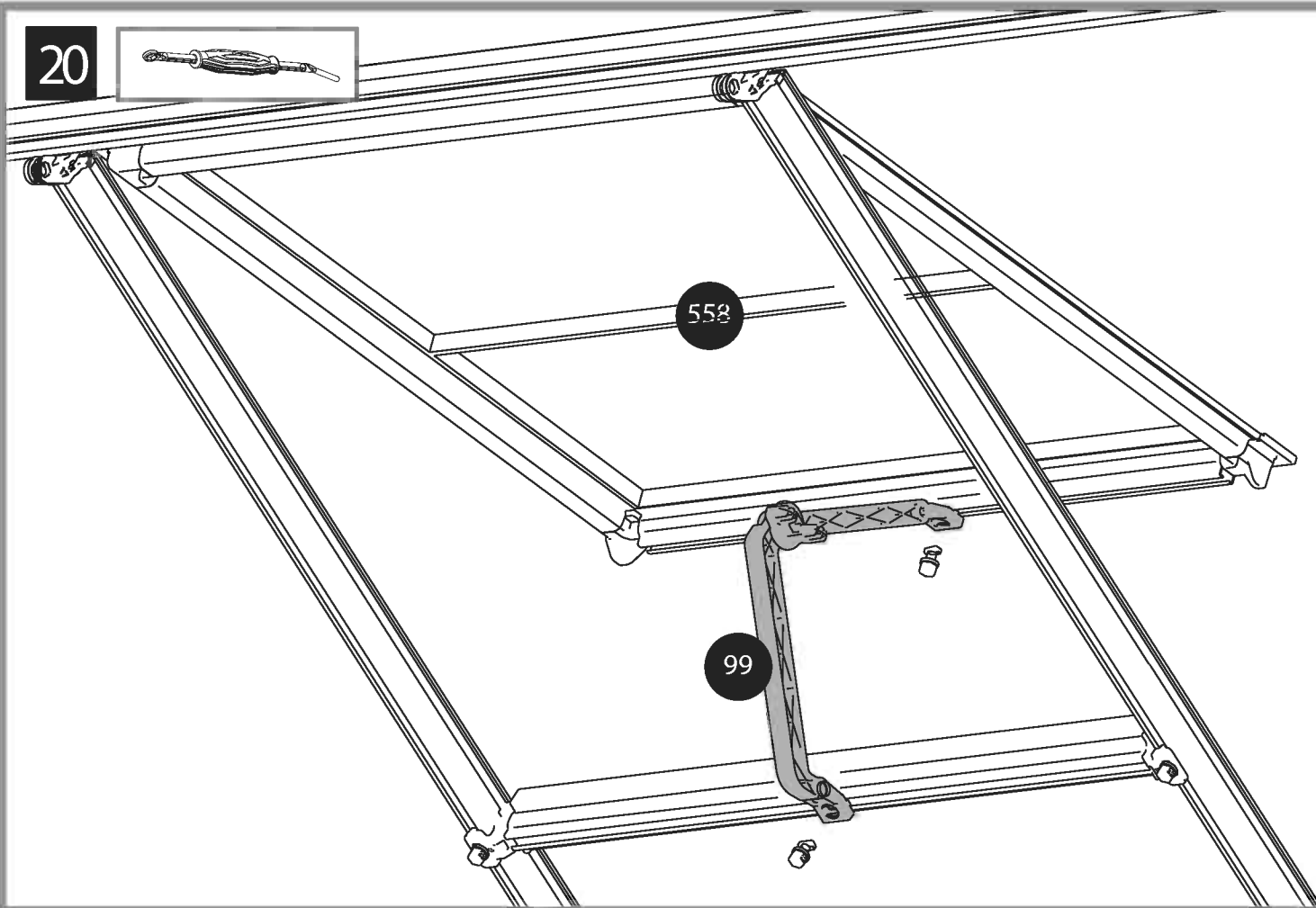
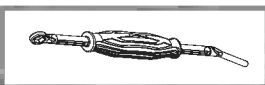

a

558

99

22

1

2

b

99

809

2

22

1

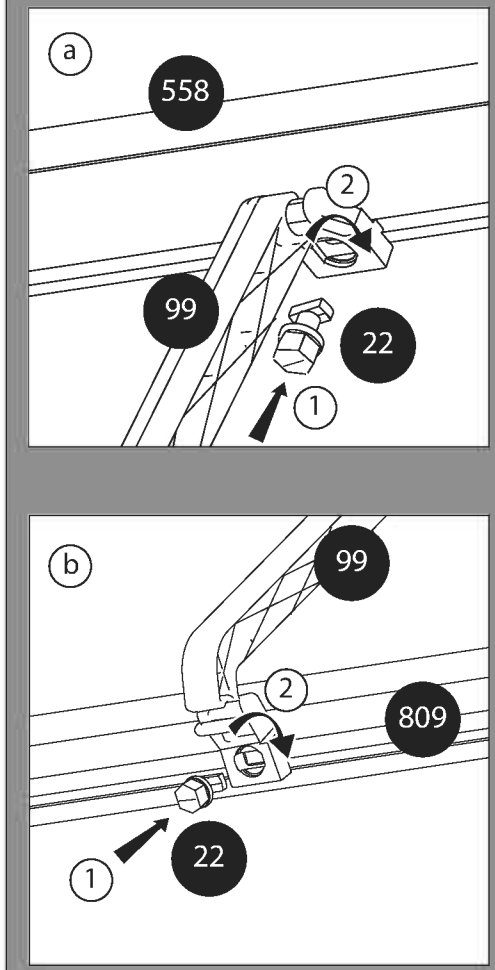

563

x 1

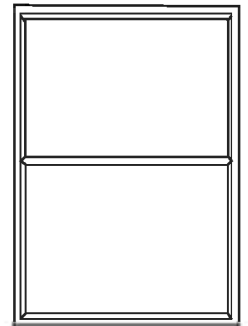

21

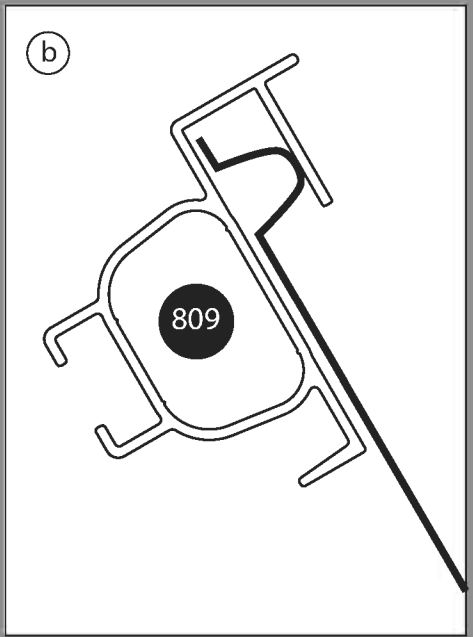
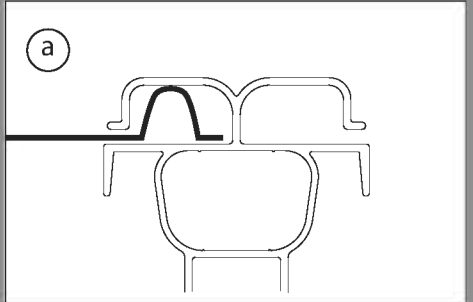
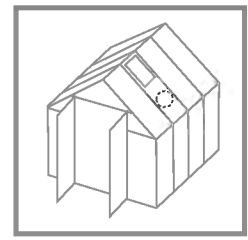
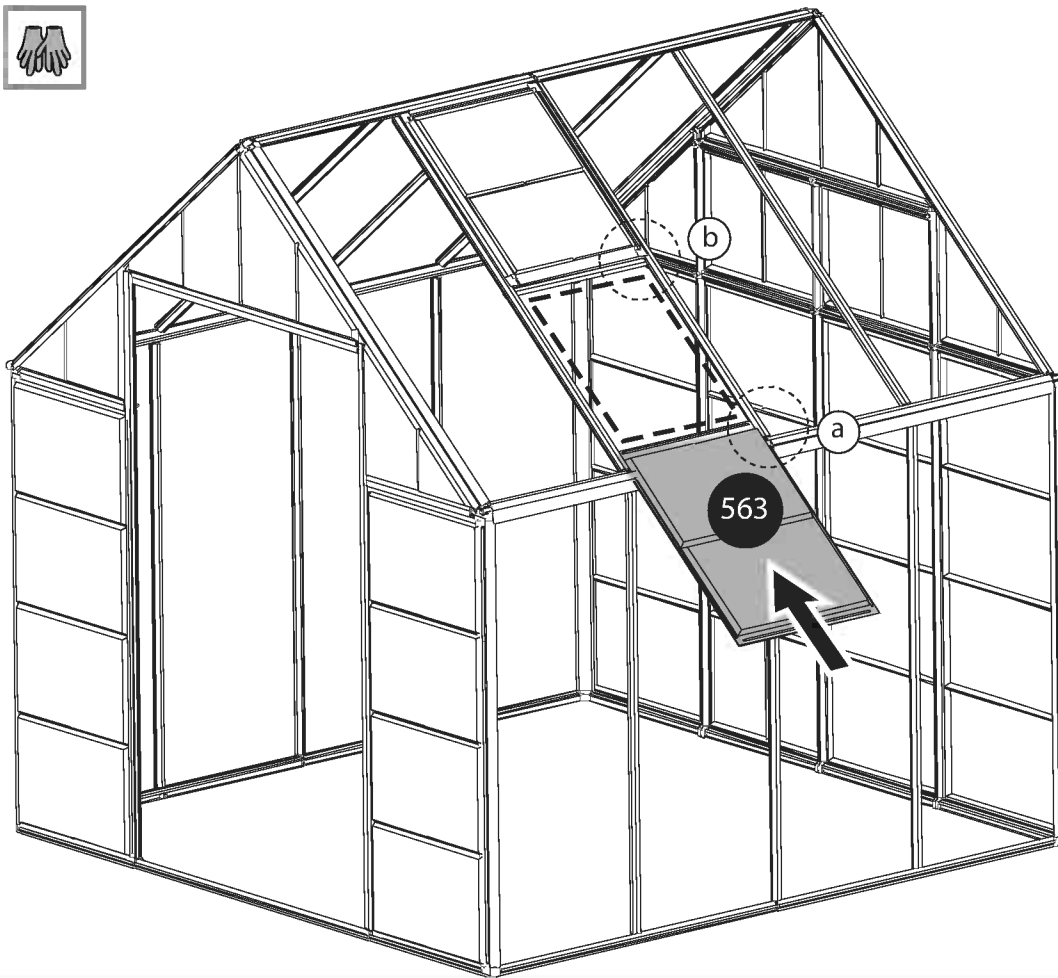

X2

566

x 15

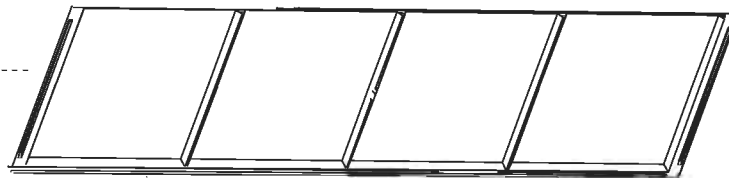

22

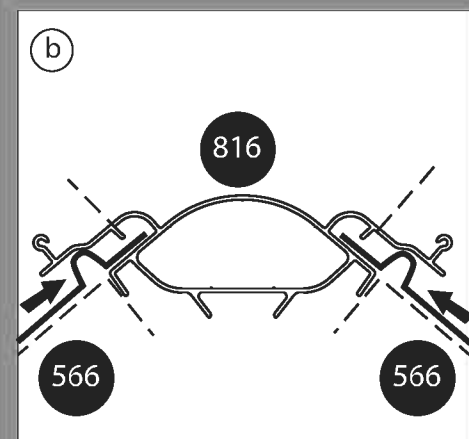
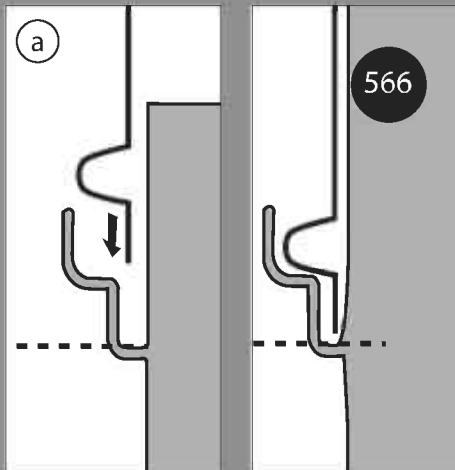
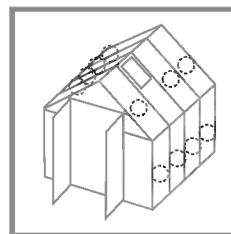
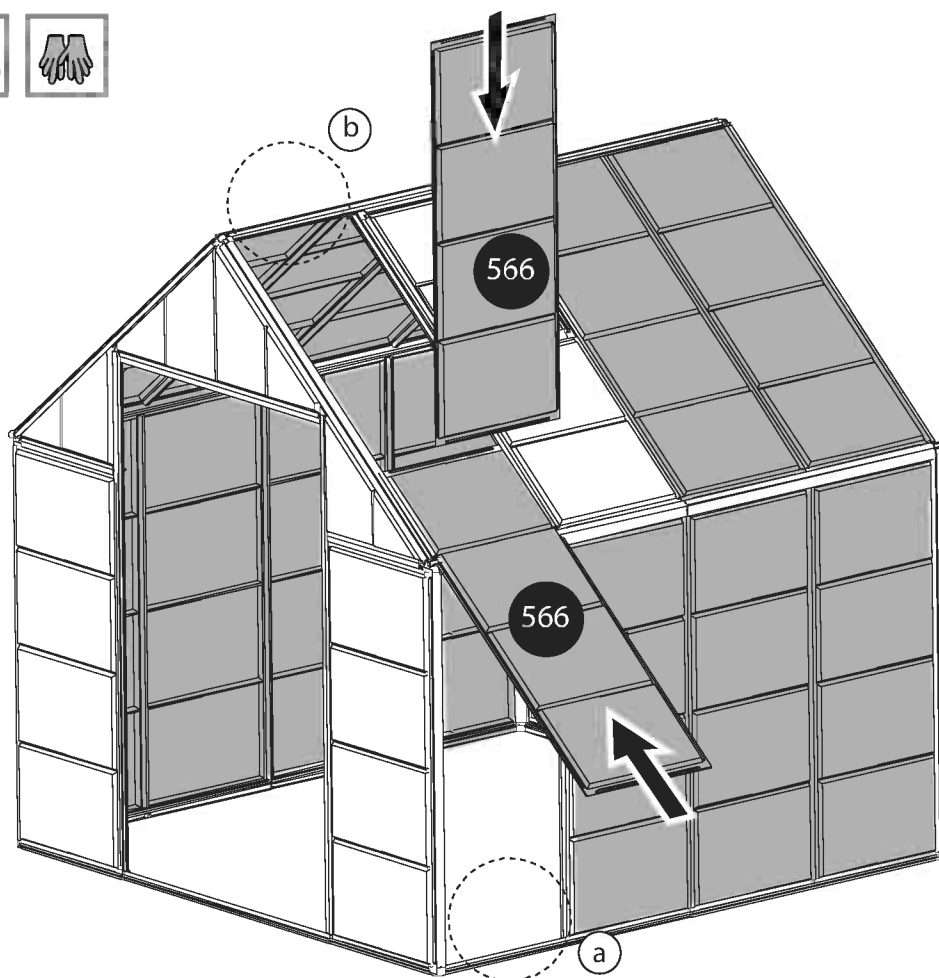

23

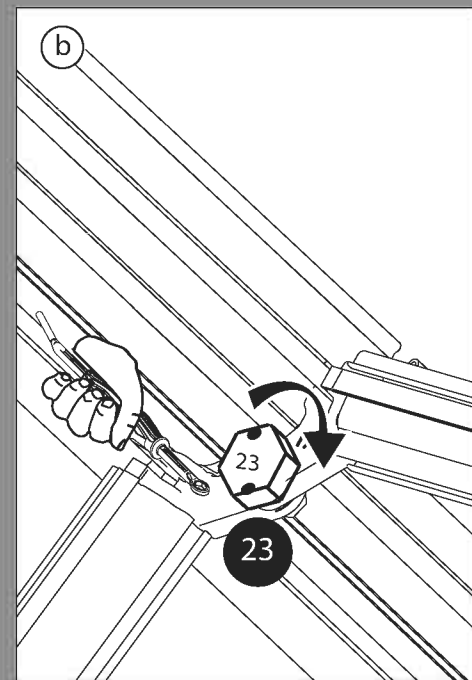
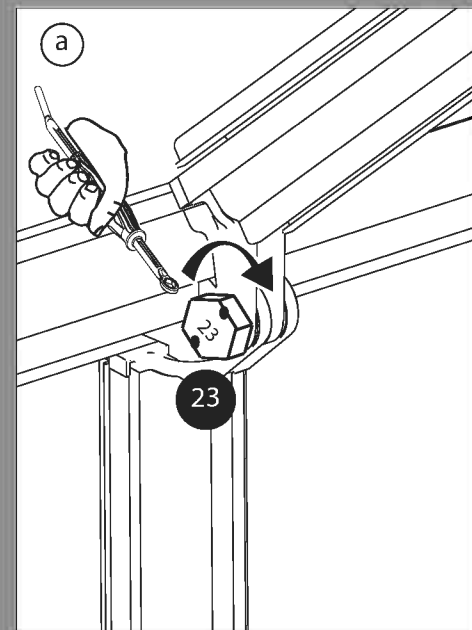
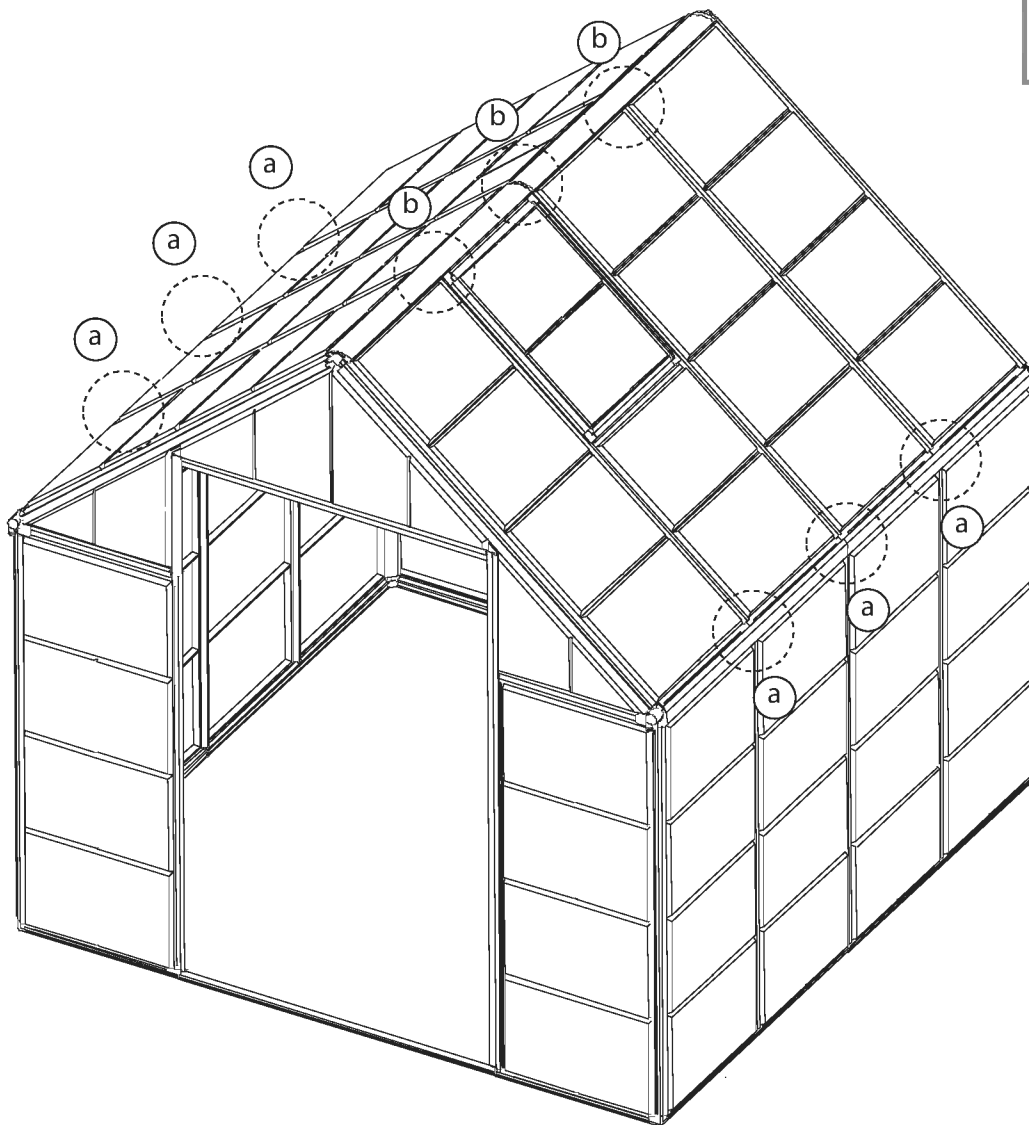
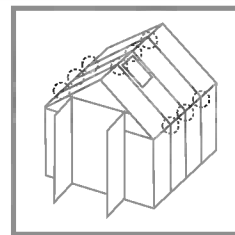
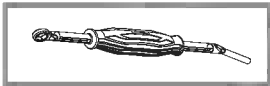

815 x 2

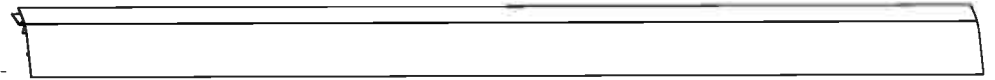

814 x 4



24

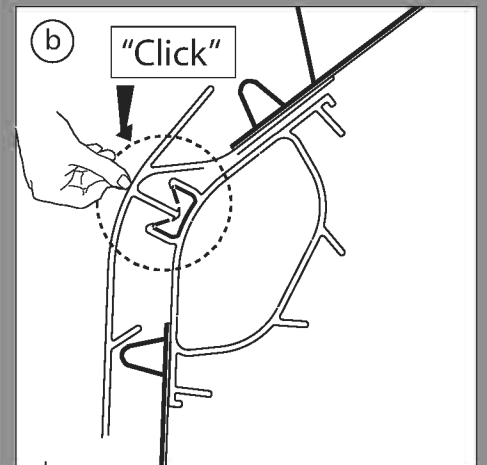
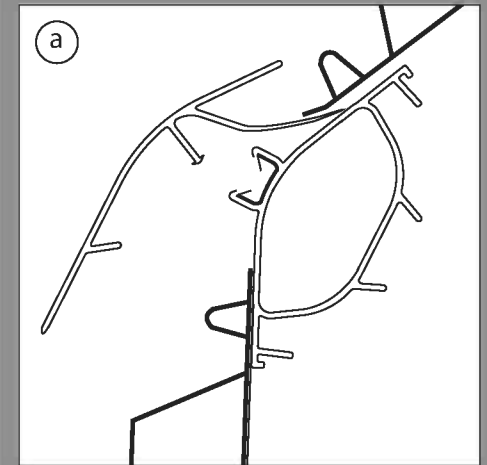
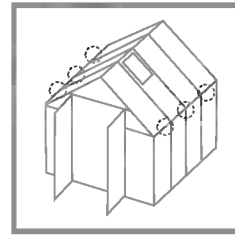
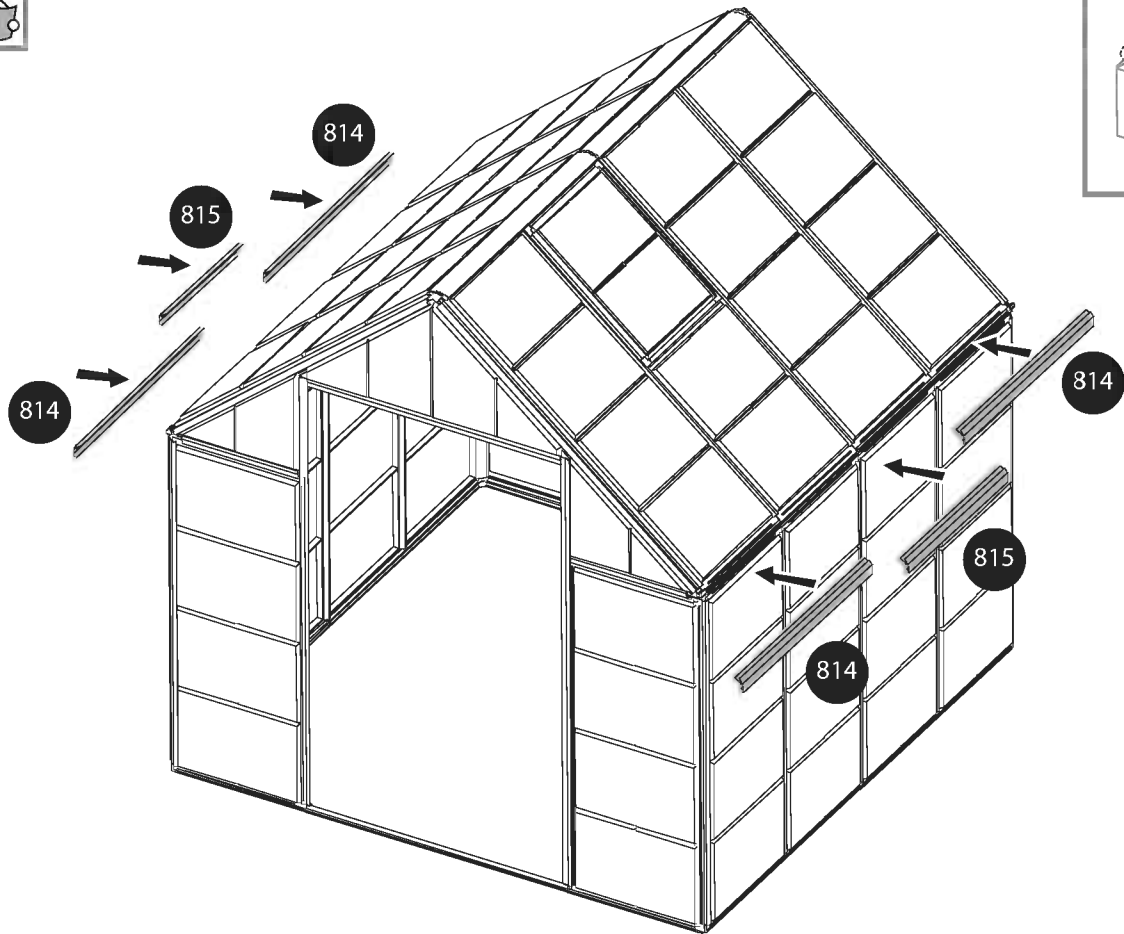

49A x 1

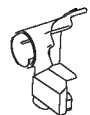

49B x 1

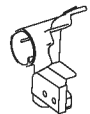

34 x 1



47 x 2

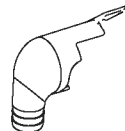

46 x 2

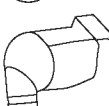

363 x 1



447 x 6



450 x 2



48 x 2



25

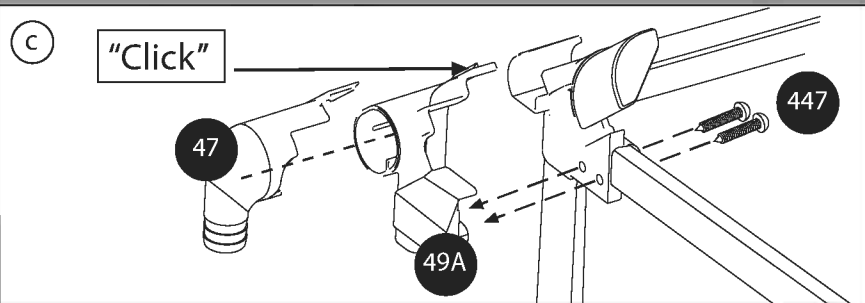
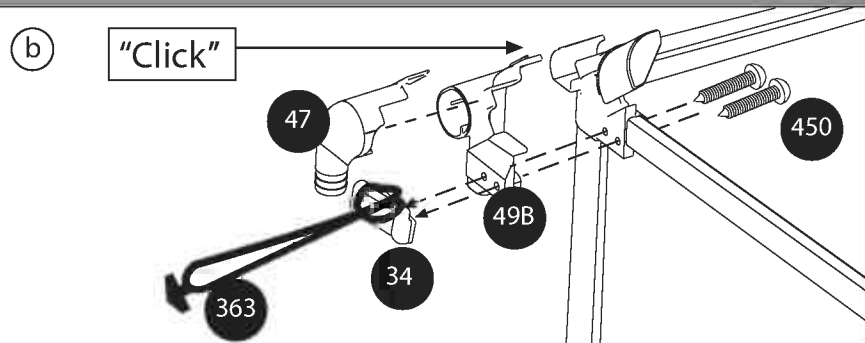
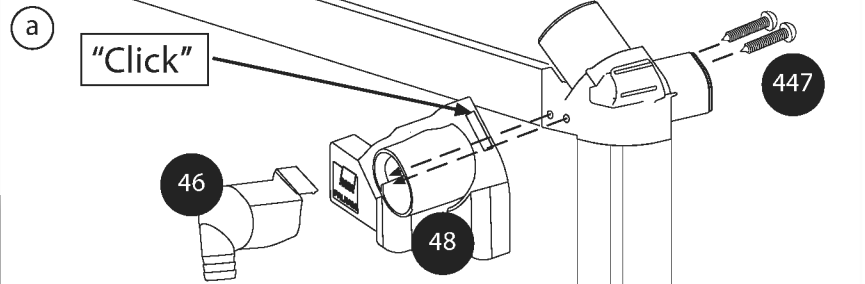
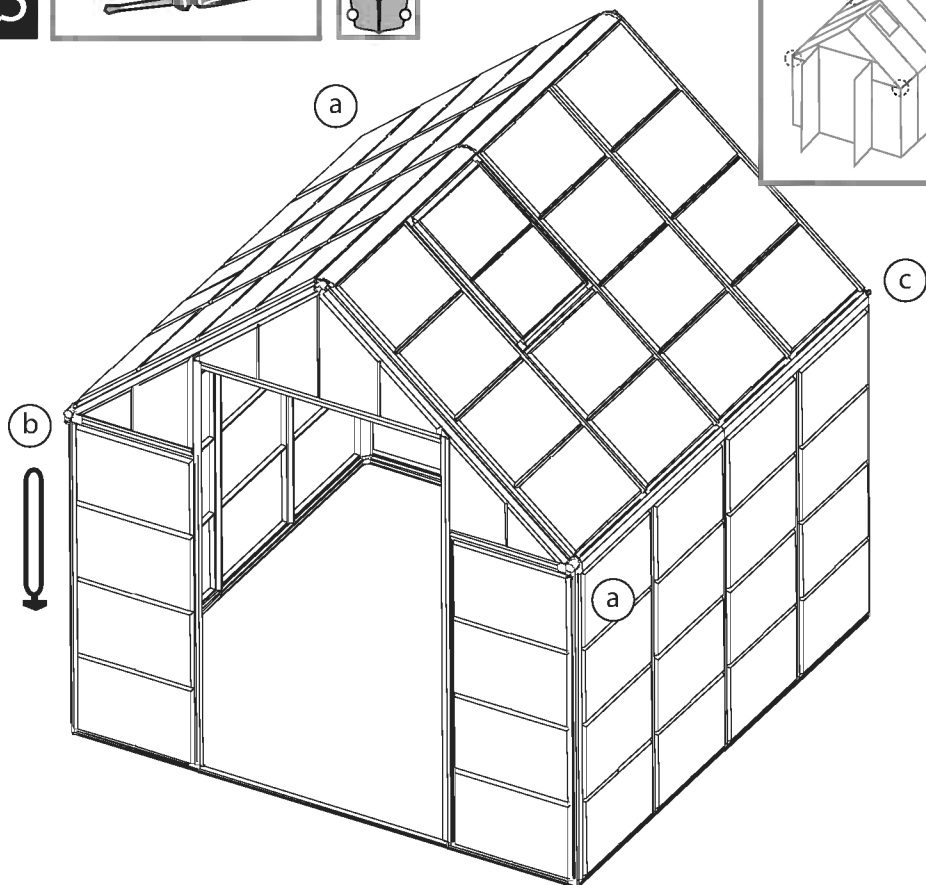
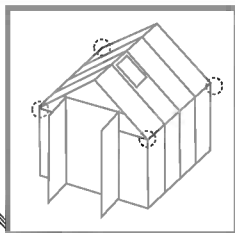

852 x 2

833 x 4

851 x 1

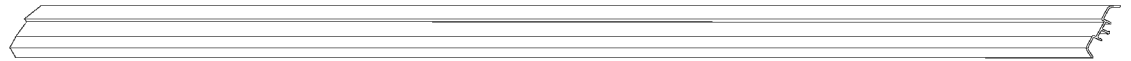
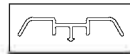
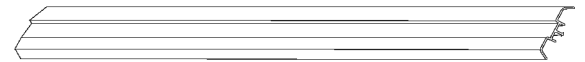
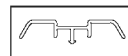
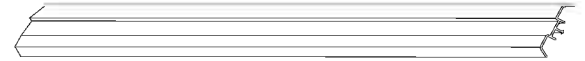
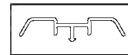

26

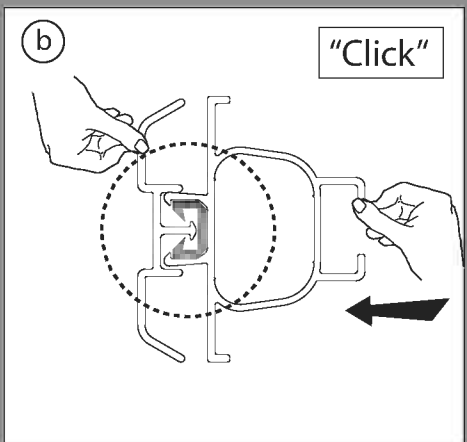
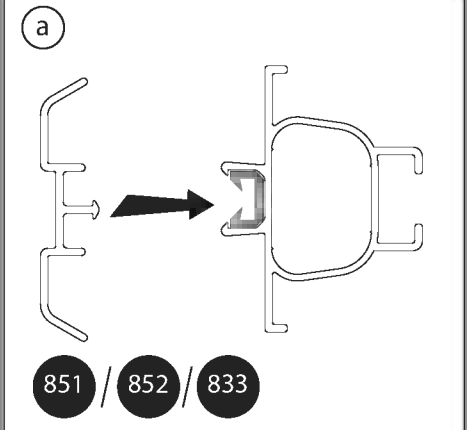
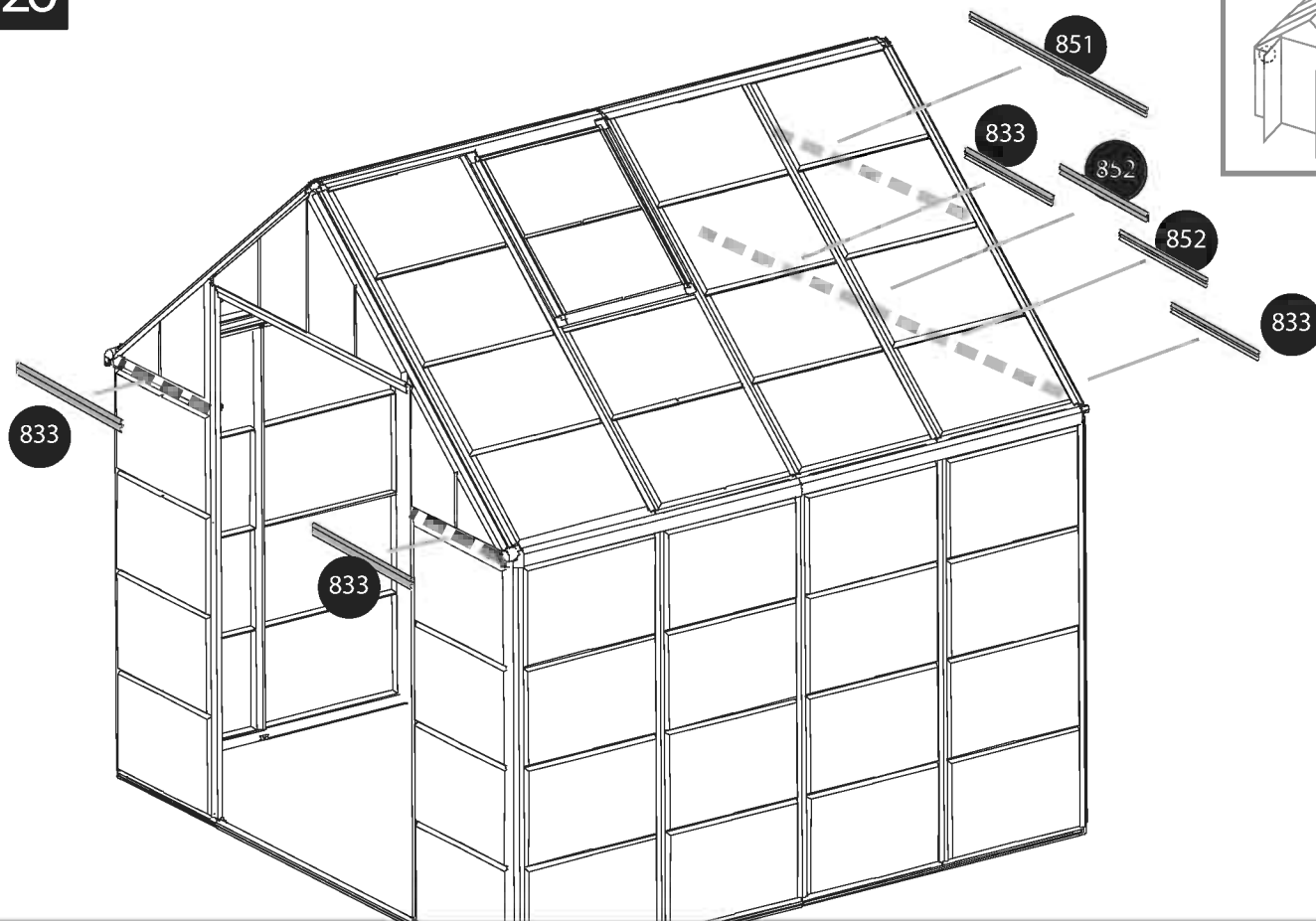

464

x 8



422

x 16



465

x 16



27



7mm

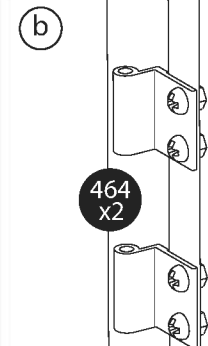
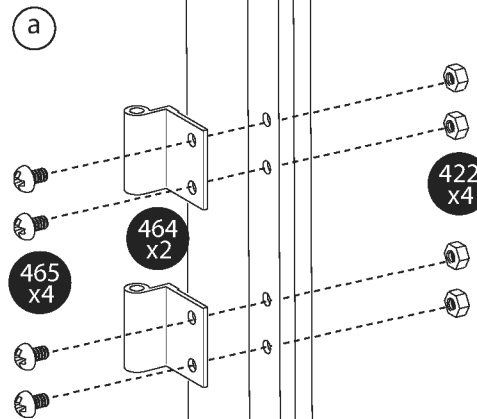
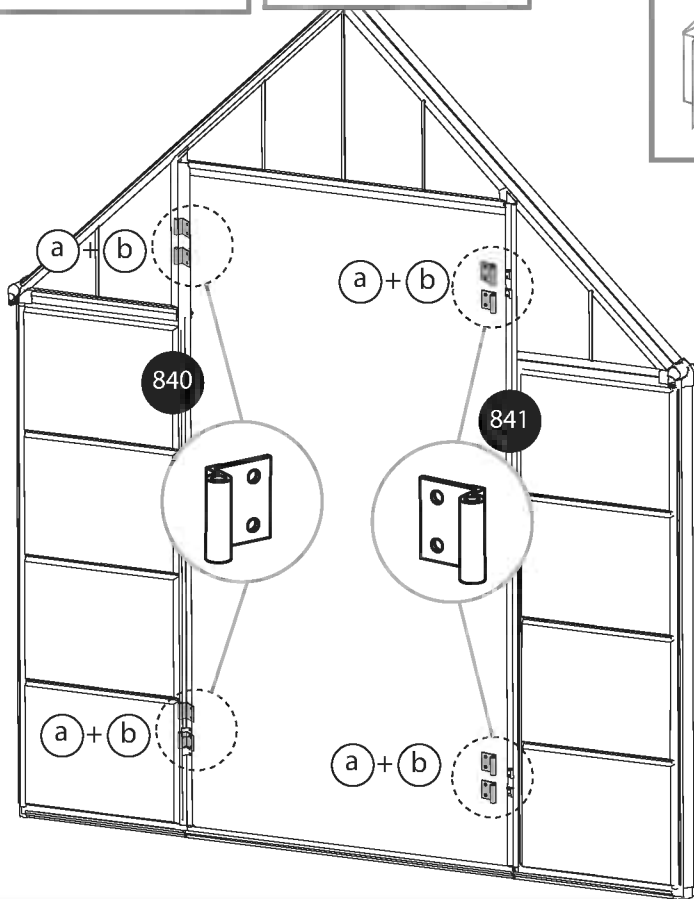
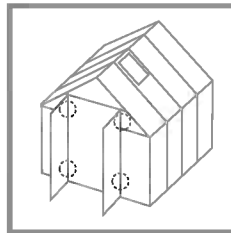

x4

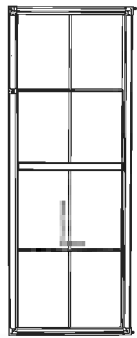

564 x 1

565 x 1

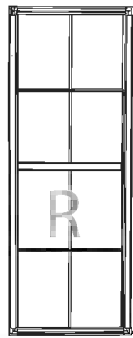

28 x 5

29A x 2

29B x 3

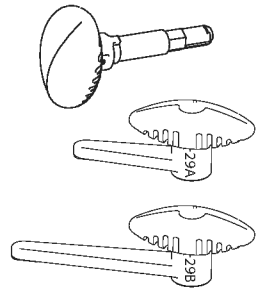

28

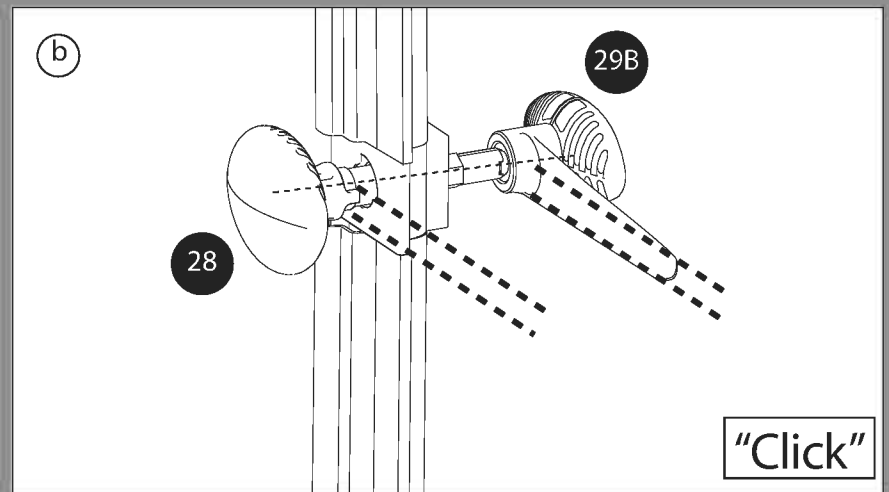
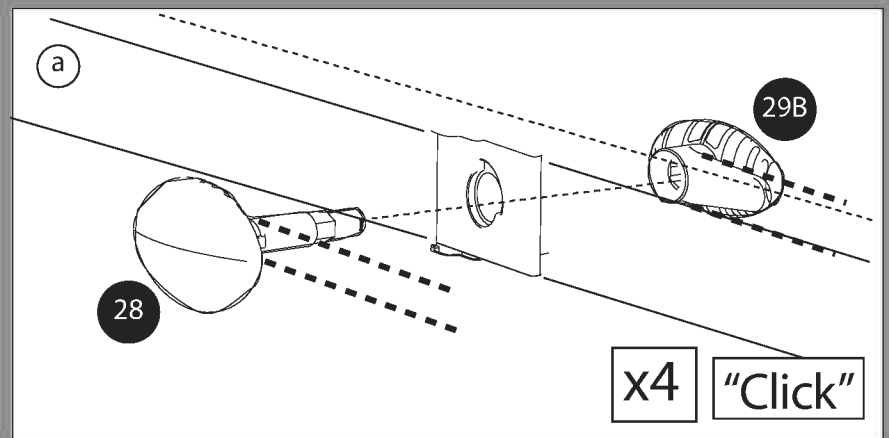
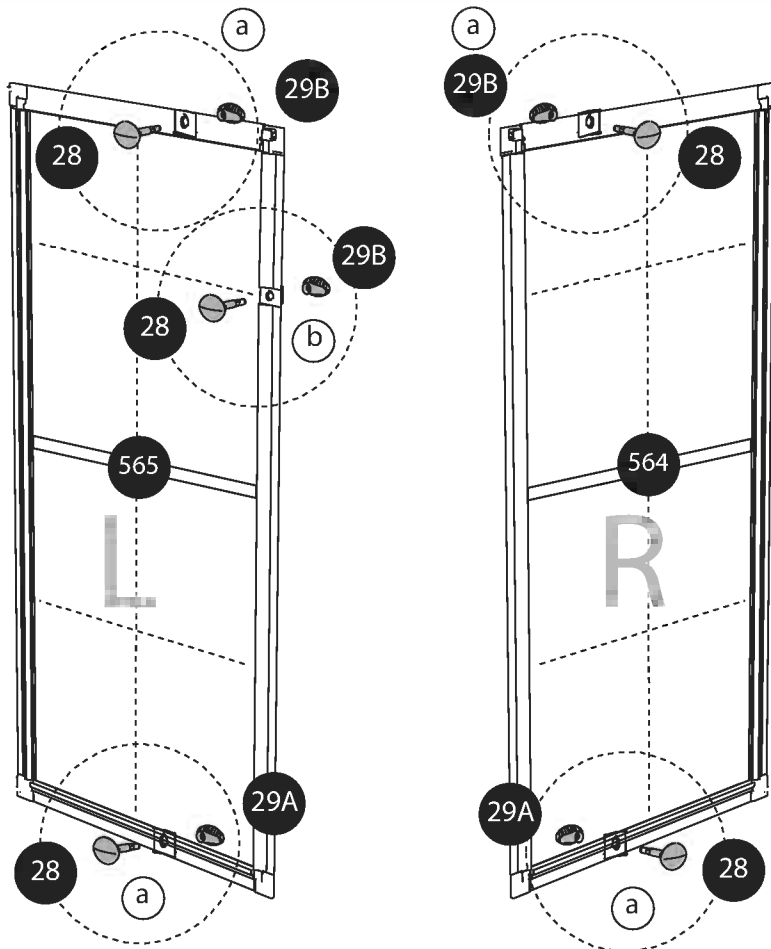

411

x 8



462

x 4

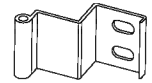

466

x 8



29

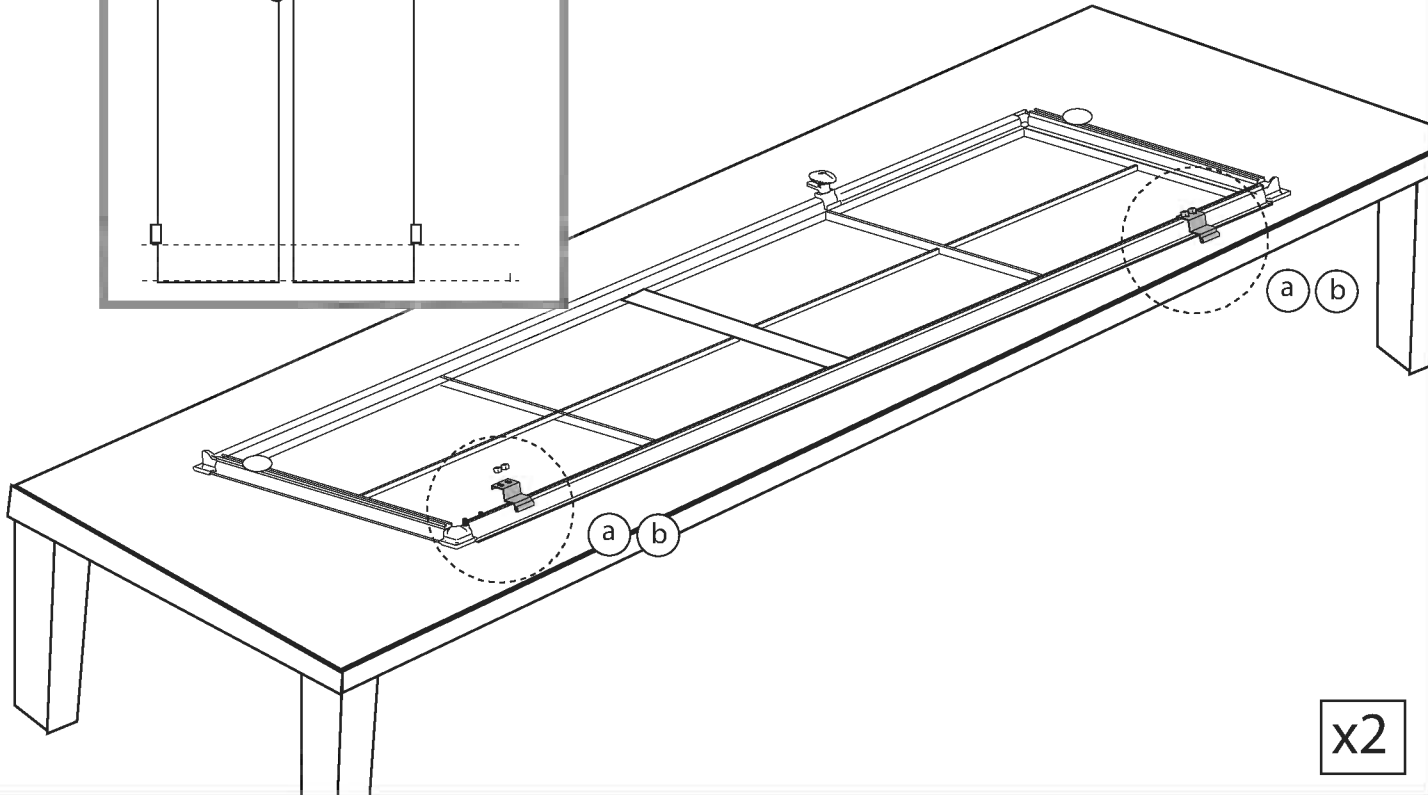
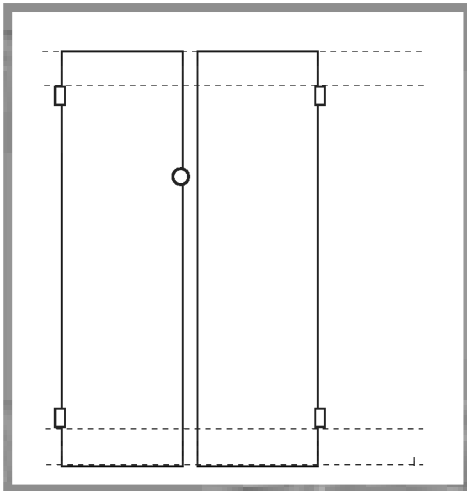

x2

a

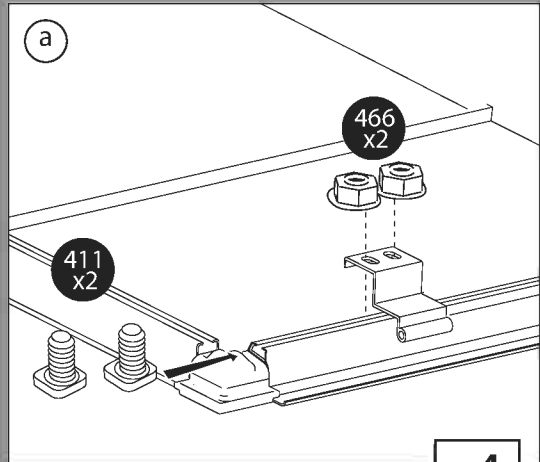

466 x2

411 x2

x4

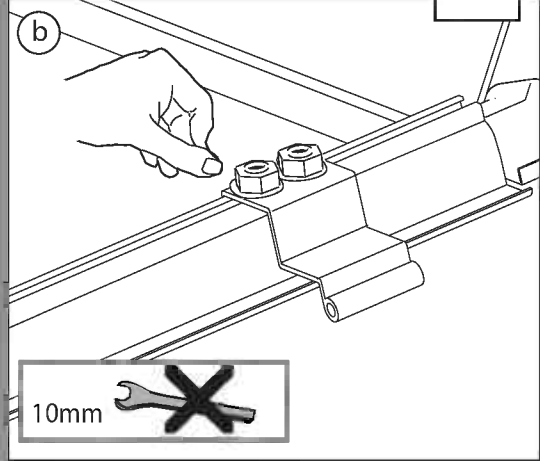

10mm



463

x 4



30

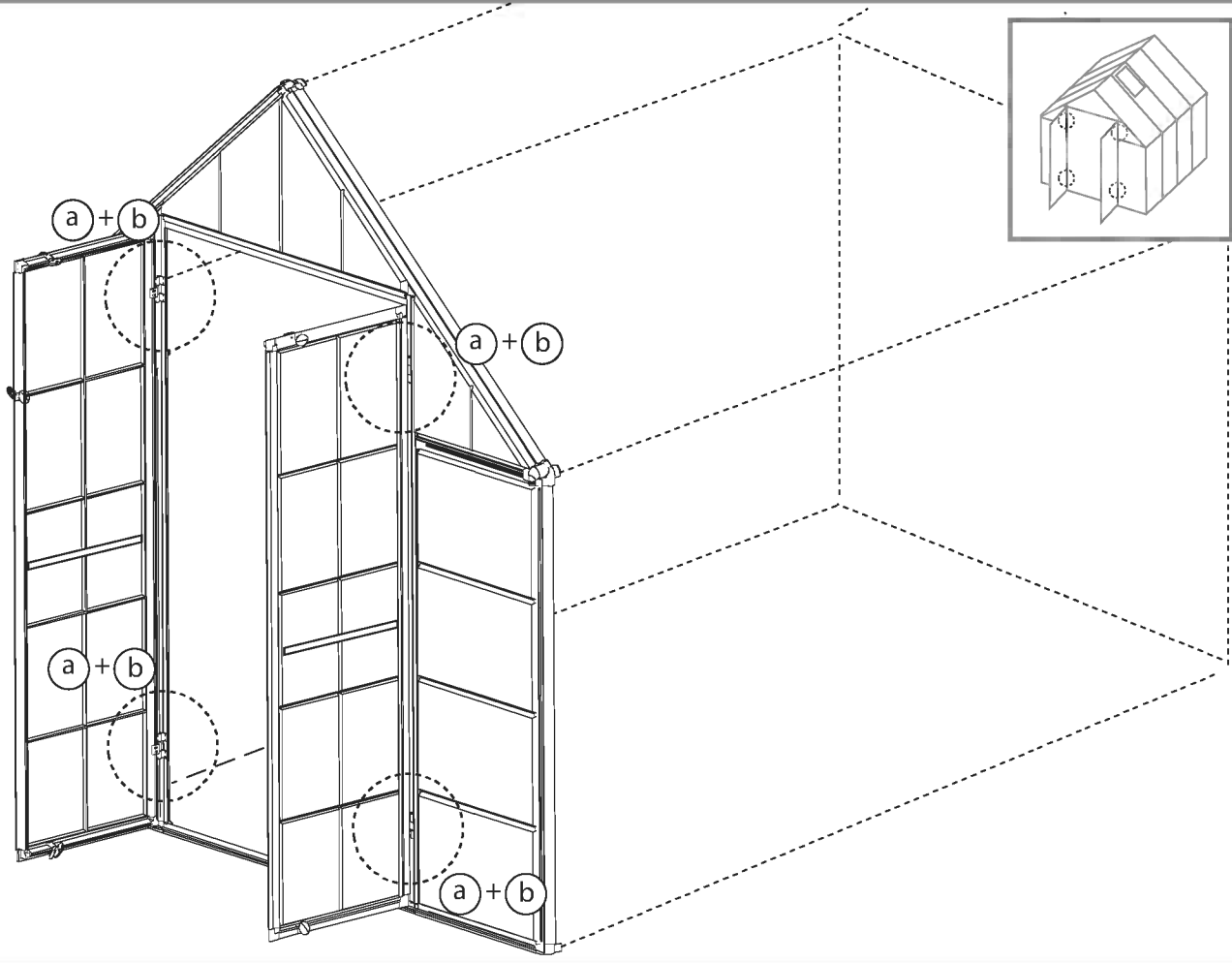

a

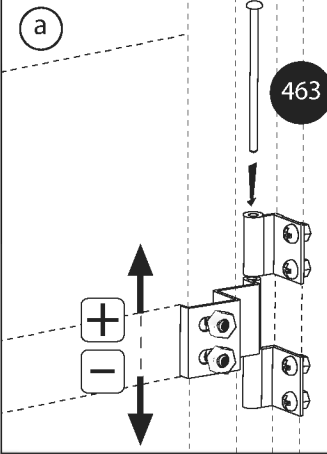

463

x4

b

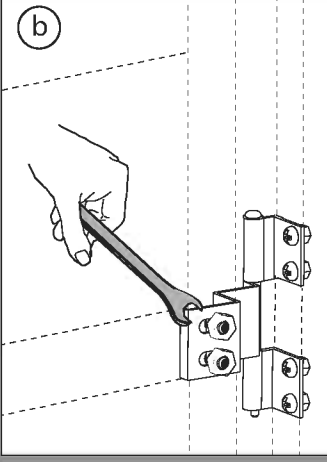

300 x 2



101 x 2



31

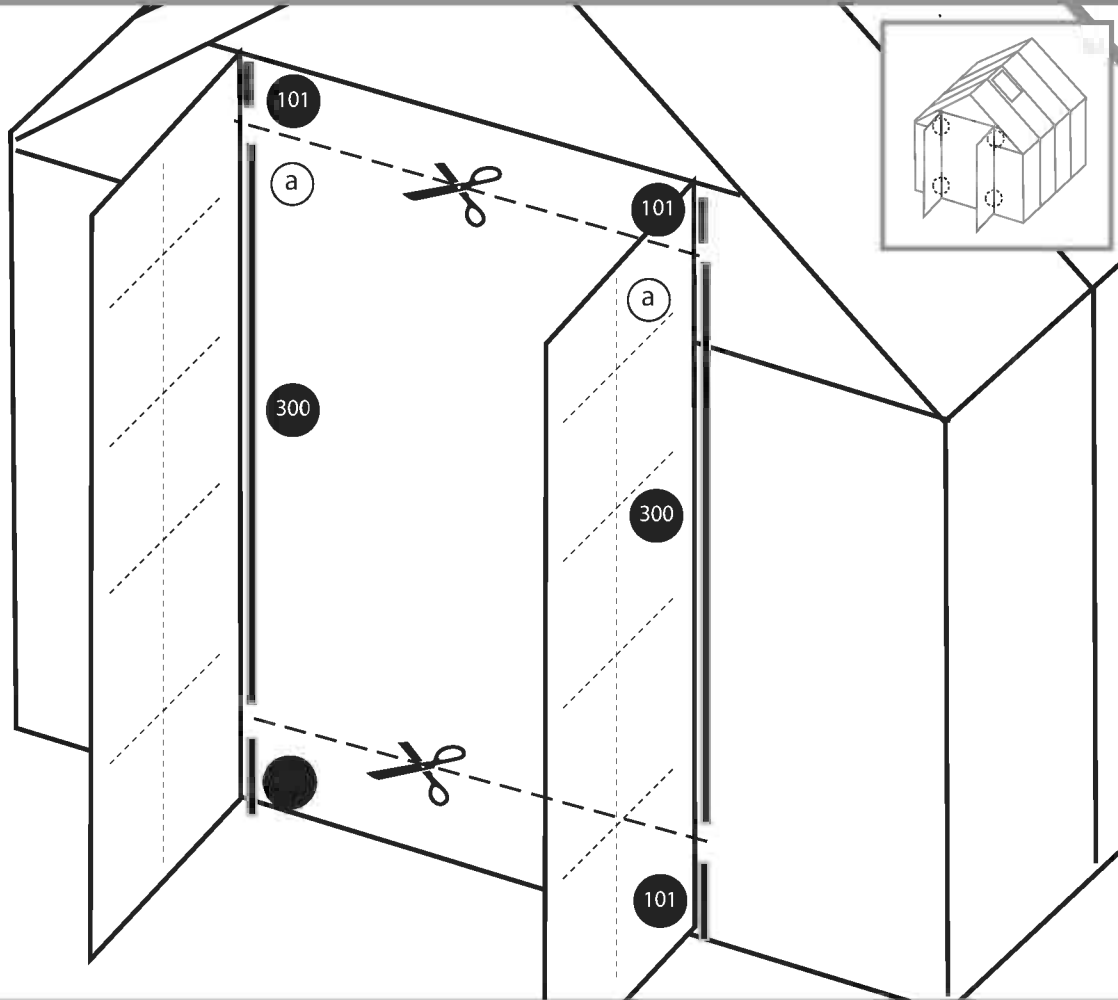

a

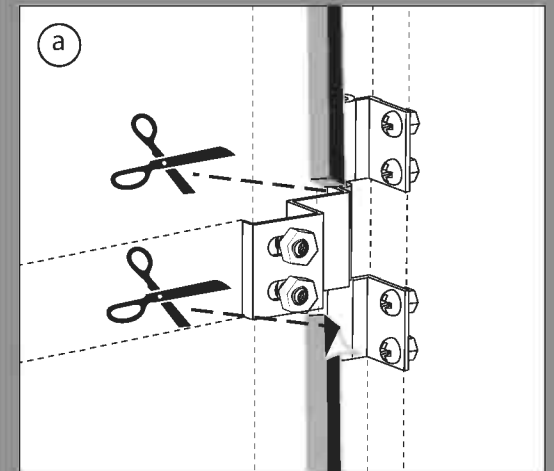

b

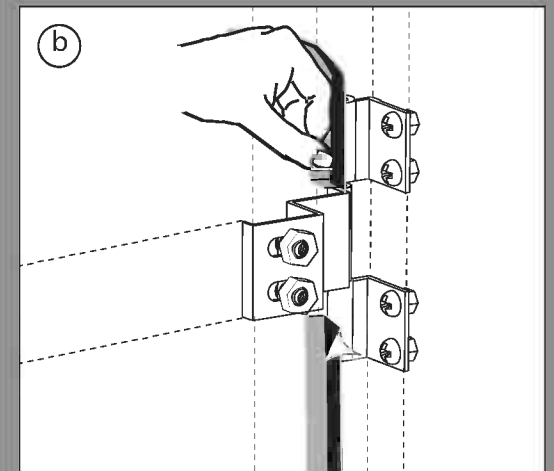

459 x3

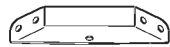

927 x2

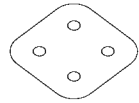

461 x40



460 x6

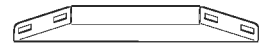

466 x40



32

10mm

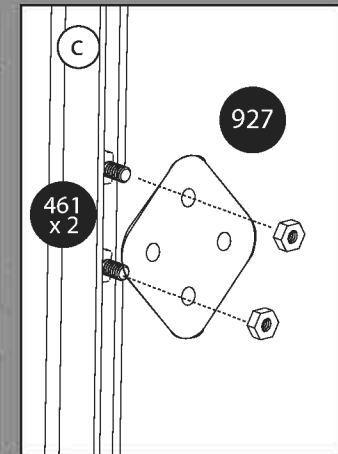
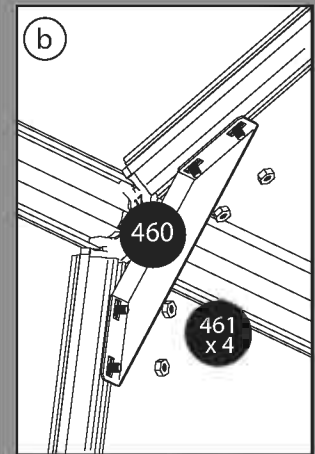
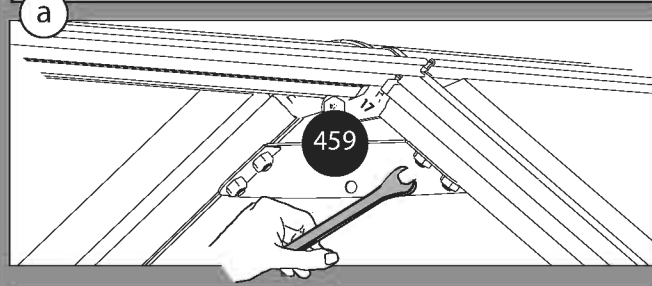
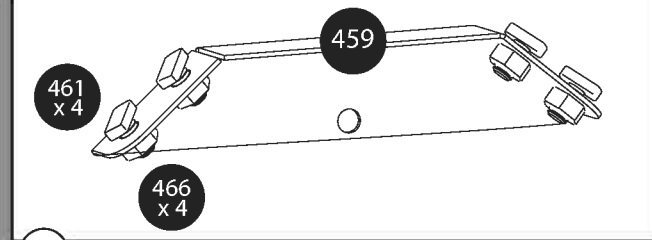
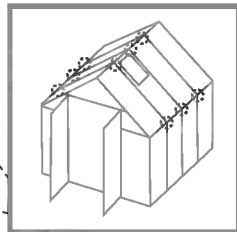
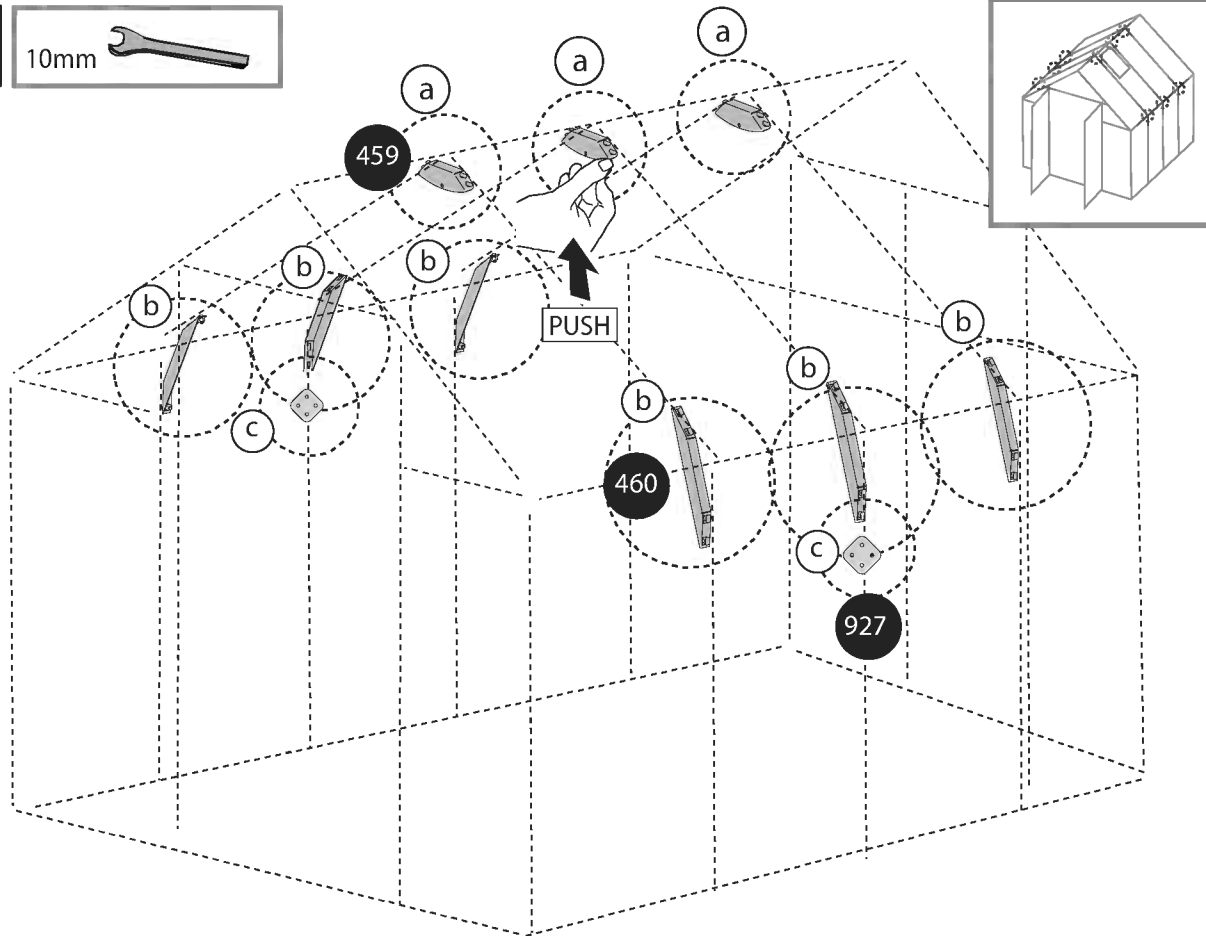

256 x 4

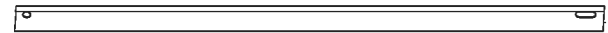

466 x 12



411 x 8



33 10mm 

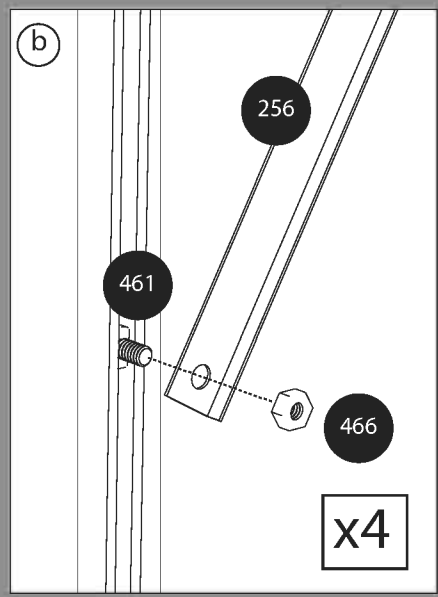
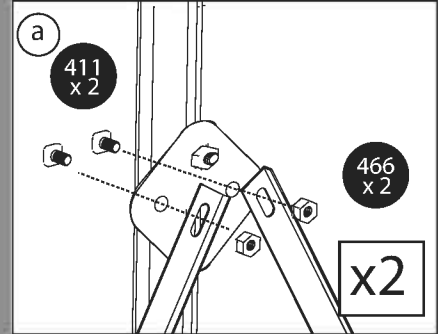
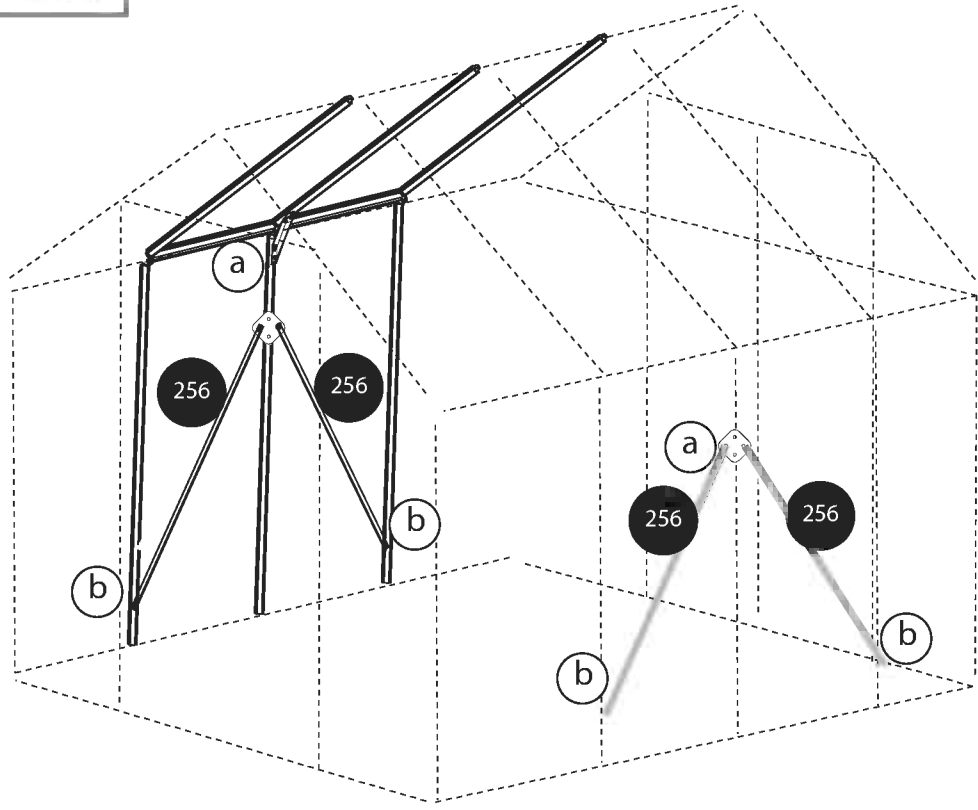

853

x 2



466

x 16



411

x 8



456

x 2

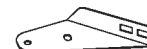

926

x 2



461

x 8



34

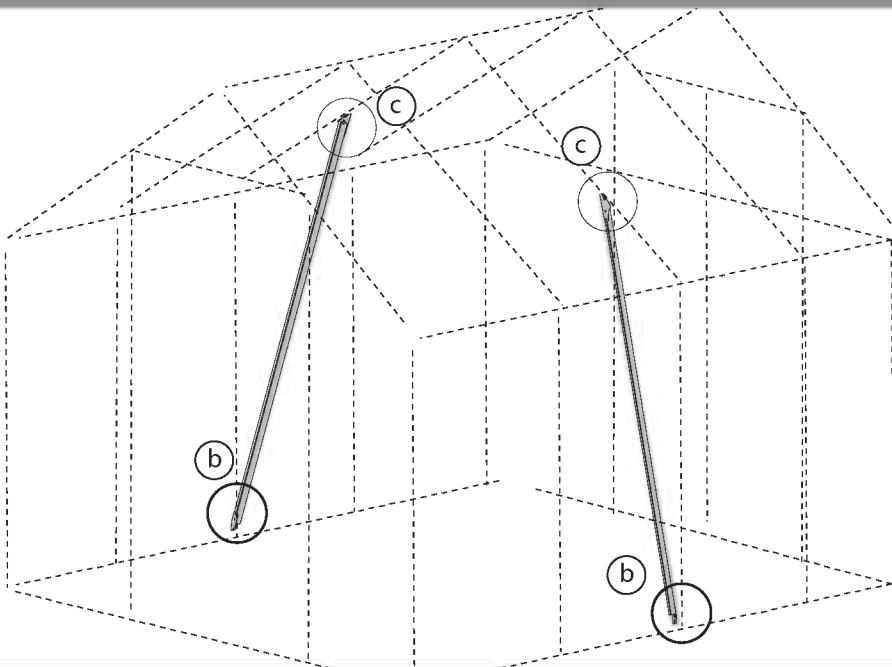
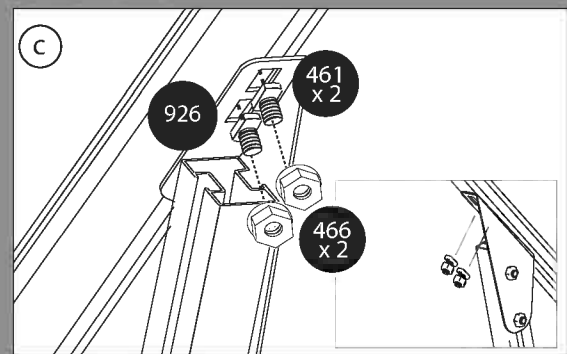
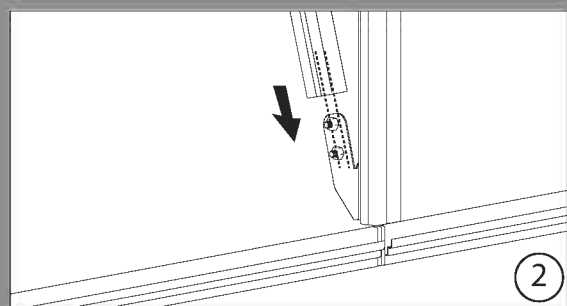
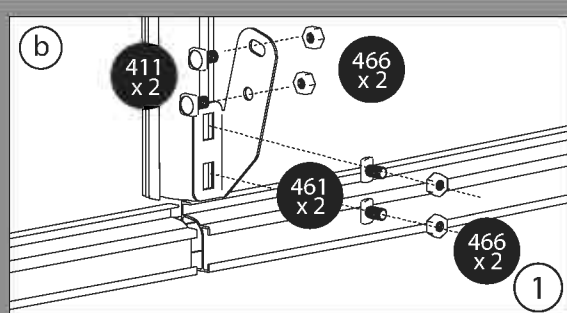
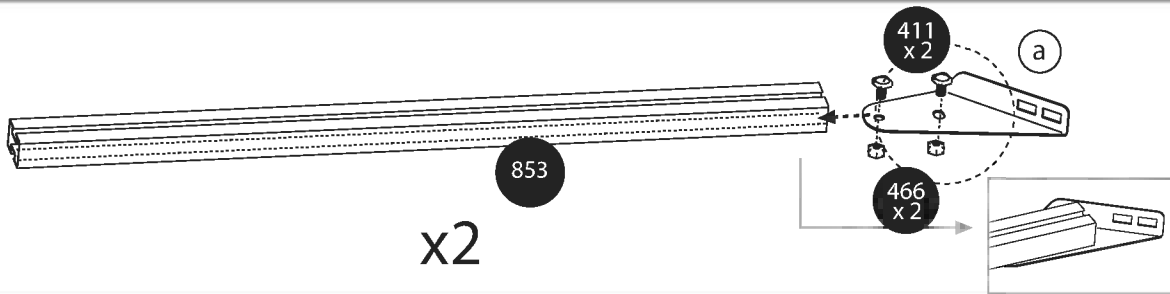

10mm



461 x 4



256 x 4

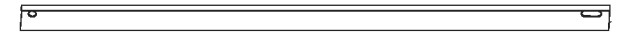

466 x 8



411 x 4



35

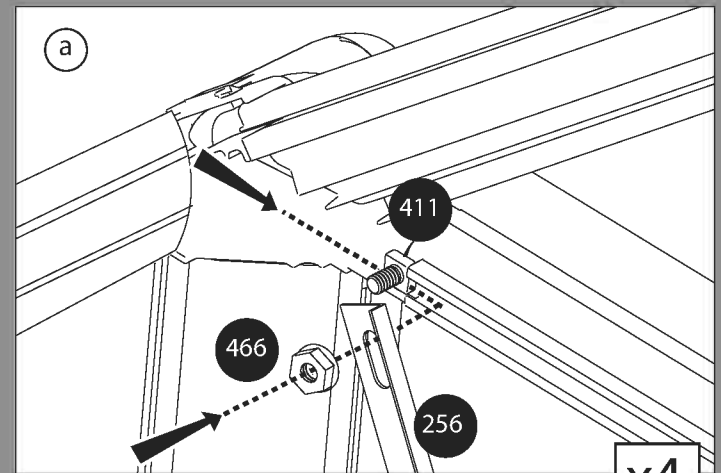
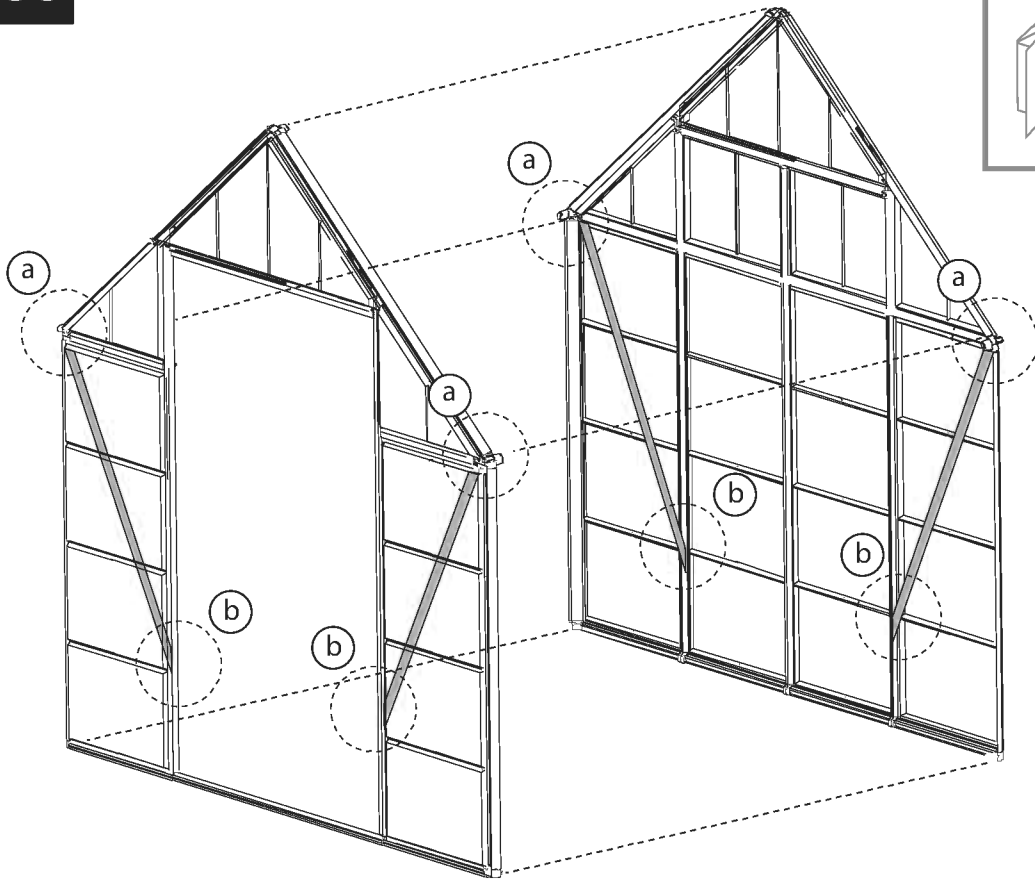
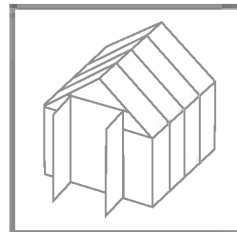

x4

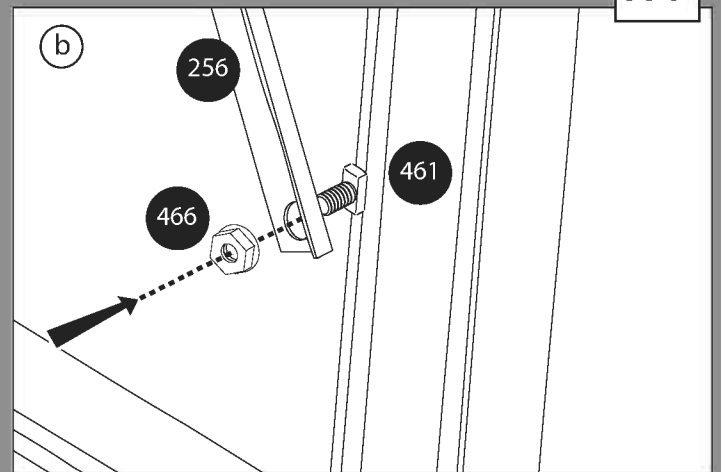

461 x 8



98B x 2

466 x 8

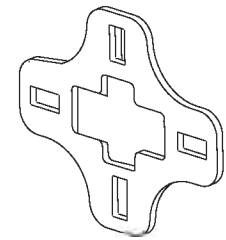

36

