



www.lifetime.com

**\*\*U.S. and Canada customers ONLY\*\***  
 IF ASSISTANCE IS NEEDED,  
**DO NOT CONTACT THE STORE!**  
 CALL OUR CUSTOMER SERVICE DEPARTMENT at **1 (800) 225-3865**  
 HOURS: 7:00 a.m. to 5:00 p.m. Monday through Friday (Mountain Standard Time)  
 \*\*Call or visit our Web site for Saturday hours\*\*

\*\*For customers outside the U.S. or Canada, please contact the store for assistance.\*\*

**COMPETITION SERIES XL POWER LIFT®  
 BASKETBALL SYSTEM**

**MODEL #71525**

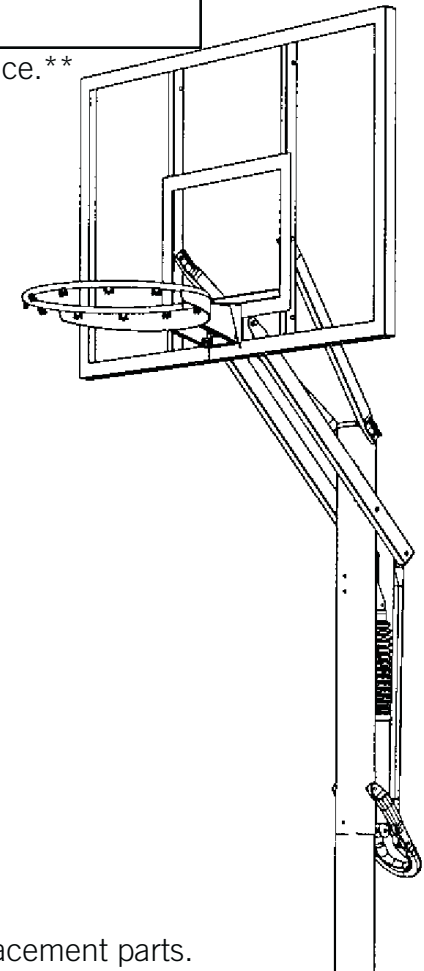

**WARNING**

Failure to comply with any of the warnings in these instructions may result in serious personal injuries such as cuts, broken bones, nerve damage, paralysis, brain injury, or death. Failure to comply may also result in property damage. Please heed all warnings and cautions. To ensure your safety, do not attempt to assemble this system without reading and following all instructions carefully. Identify and inventory the parts using the Parts List.

**ASSEMBLY INSTRUCTIONS AND OWNER'S MANUAL**

**\*\*A MINIMUM OF TWO ADULTS ARE REQUIRED FOR ASSEMBLY\*\***

Save this instruction in the event that the manufacturer has to be contacted for replacement parts.

# PARTS LIST

ID	Part #	Description	Qty	✓
TP	1030700	Top Pole	1	<input type="checkbox"/>
MP	1030701	Middle Pole	1	<input type="checkbox"/>
BP	1030859	Bottom Pole	1	<input type="checkbox"/>
AB	DD00800	Net	1	<input type="checkbox"/>
AC	502027H	Handle	1	<input type="checkbox"/>
AD	502049G	Trigger	1	<input type="checkbox"/>
AE	1030667	Extension Arm (Long)	2	<input type="checkbox"/>
AA	1030669	Extension Arm (Short)	2	<input type="checkbox"/>
AF	502056	Plastic Guard	1	<input type="checkbox"/>
AK	CA00885	Zip Tie	2	<input type="checkbox"/>
AL	604084	Height Sticker	1	<input type="checkbox"/>
AM	1030660	Spring Bracket	1	<input type="checkbox"/>
AN	HA00800	Gas Spring	1	<input type="checkbox"/>
AO	825619	Rim	1	<input type="checkbox"/>
AP	1030781	Backboard Bracket Right	1	<input type="checkbox"/>
AQ	1030762	Backboard Bracket Left	1	<input type="checkbox"/>
AR	1030758	Rear Lifter Arm	2	<input type="checkbox"/>
AS	ZA10185	Bellows	1	<input type="checkbox"/>
AU	1030727	Backboard	1	<input type="checkbox"/>
AW	500096	Pole Cap	1	<input type="checkbox"/>
AX	1021852	Rim Cover Plate	1	<input type="checkbox"/>
FL	CA00299	Left Frame Pad	1	<input type="checkbox"/>
FR	CA00399	Right Frame Pad	1	<input type="checkbox"/>
FB	CA00999	Bottom Frame Pad	2	<input type="checkbox"/>
FM	FS16500	Sticker, Warning (Applied)	1	<input type="checkbox"/>
AJ	700506	Wood Block	1	<input type="checkbox"/>
<b>Rim Hardware (1013678)</b>				
RA	BS01000	#7 x 3/8" Screw	4	<input type="checkbox"/>
RB	300104	3/8" Push Nut	2	<input type="checkbox"/>
RC	300106	5/16" x 2" Carriage Bolt	2	<input type="checkbox"/>
RD	300128	Jam Nut	2	<input type="checkbox"/>
RE	302079	3 1/2" x 5" x 5/16" U-Bolt	1	<input type="checkbox"/>
RF	302090	5/16" Nylock Flange Nut	4	<input type="checkbox"/>
RG	1001137	Compression Spring	2	<input type="checkbox"/>
RH	510038	3/8" x 5 1/2" Axle	1	<input type="checkbox"/>
RI	804018	Rim Pivot Bracket	1	<input type="checkbox"/>
RJ	804033	Spring Retainer Plate	1	<input type="checkbox"/>
<b>Pole Joint Hardware (1005748)</b>				
PA	BS02000	1/4" x 3/4" Screw	2	<input type="checkbox"/>
PB	1004620	Self-Tapping Screw	2	<input type="checkbox"/>
<b>Frame Pad Hardware (HH00700)</b>				
FA	BS00100	#10 x 3/4" Self-Drilling Screw	10	<input type="checkbox"/>

# HARDWARE IS ACTUAL SIZE

(Unless otherwise indicated)

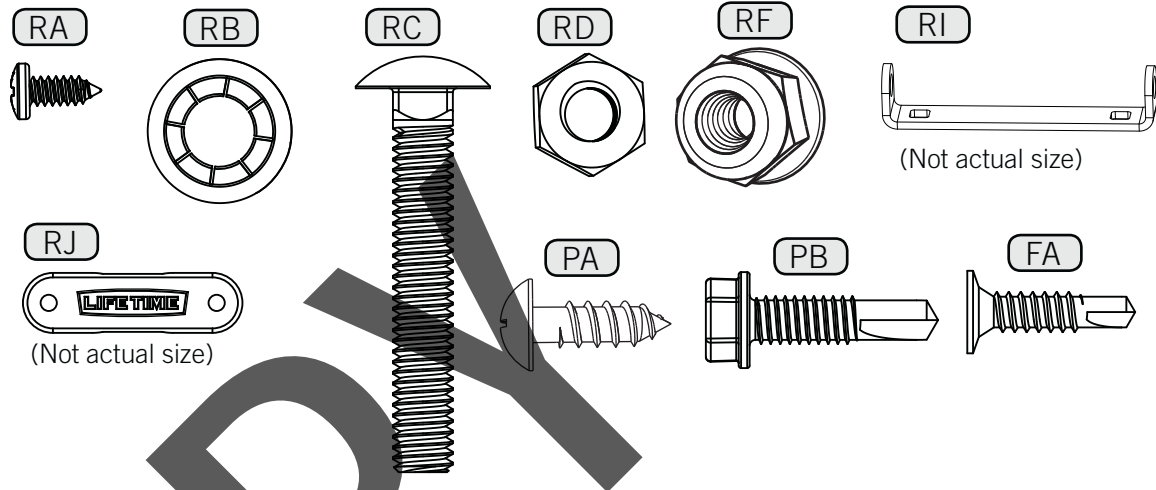

## Tools and Materials Required for Assembly

(Not Included)

- |                                 |                                 |
|---------------------------------|---------------------------------|
| 1. Adjustable Wrench            | 9. Tape Measure                 |
| 2. Phillips Screwdriver         | 10. Punch/Dowel or similar tool |
| 3. 1/2" Wrenches (2)            | 11. Pliers                      |
| 4. 9/16" Wrenches (2)           | 12. Scissors/Wire Cutters       |
| 5. 3/4" Wrenches (2)            | 13. Scrap Wood or Cardboard     |
| 6. 11/16" Wrench                | 14. Electric Drill              |
| 7. Hammer or Mallet             | 15. 1/2" Socket Wrench          |
| 8. 90 lb. Concrete Mix Bags (6) | 16. 1/2" x 3' Rebar             |

## BEFORE BEGINNING ASSEMBLY



- Identify and inventory all parts using the checklist boxes on the Parts List. Keep the hardware bags and their contents separate. If any parts are missing, call our Customer Service Department.
- Test fit all Bolts by inserting them into their respective holes. If necessary, carefully scrape away any excess powder coating buildup from inside the holes. Do not scrape away all of the powder coating. Bare metal may rust. You may need to pound some Bolts into place with a hammer or mallet.

# PARTS LIST

ID	Part #	Description	Qty	✓
<b>Handle Hardware (1017923)</b>				
HA	302007	3/8" x 6 1/2" Hex Bolt	2	<input type="checkbox"/>
HB	300101	Release Pin	1	<input type="checkbox"/>
HC	302008	3/8" Centerlock Nut	2	<input type="checkbox"/>
HD	300187	1/2" x 6 1/2" Hex Bolt	1	<input type="checkbox"/>
MH	301008	1/2" Centerlock Nut	1	<input type="checkbox"/>
<b>Main Hardware (1039829)</b>				
MA	300029	1/2" x 7 1/8" Hex Bolt	5	<input type="checkbox"/>
MB	300022	1/4" Centerlock Nut	2	<input type="checkbox"/>
MC	1028047	.38" x 1" Steel Spacer	2	<input type="checkbox"/>
MD	300043	Cotter Pin	1	<input type="checkbox"/>
ME	300055	1 1/2" Metal Pin	1	<input type="checkbox"/>
MH	301008	1/2" Centerlock Nut	5	<input type="checkbox"/>
MI	300110	1/4" x 2 3/4" Hex Bolt	2	<input type="checkbox"/>
MJ	302053	3/8" x 4" Hex Bolt	2	<input type="checkbox"/>
ML	800324	1/2" x 2.31 Steel Spacer	2	<input type="checkbox"/>
MN	500032	1/2" x 1/8" Spacer	4	<input type="checkbox"/>
MO	500015	3/8" x 1/2" Handle Spacer	2	<input type="checkbox"/>
MQ	500081	Grease Packet	1	<input type="checkbox"/>
MR	800331	.62" x .706" x 3.20" Spacer	1	<input type="checkbox"/>
MT	800239	1/2" x 3.41" Spacer	2	<input type="checkbox"/>
MX	302011	5/16" x 1 1/4" Carriage Bolt	2	<input type="checkbox"/>
MY	302090	5/16" Nylock Flange Nut	2	<input type="checkbox"/>
MZ	500013	.69 x .592 Black Spacer	4	<input type="checkbox"/>
BC	300031	3/8" Flat Washer	2	<input type="checkbox"/>
HC	302008	3/8" Centerlock Nut	2	<input type="checkbox"/>

## HARDWARE IS ACTUAL SIZE

(Unless otherwise indicated)

Thread lengths may vary

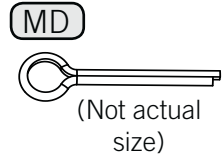
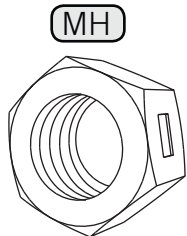
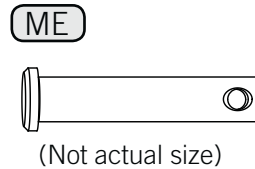
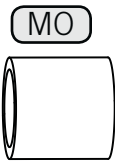
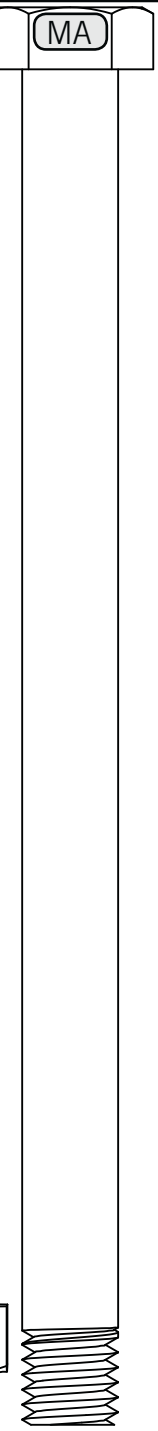
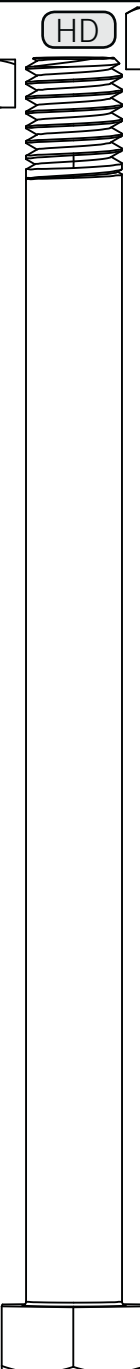
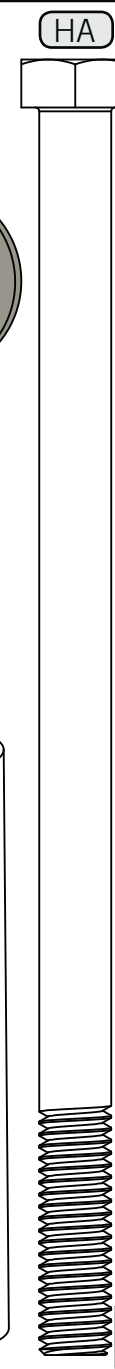
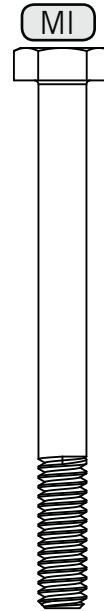
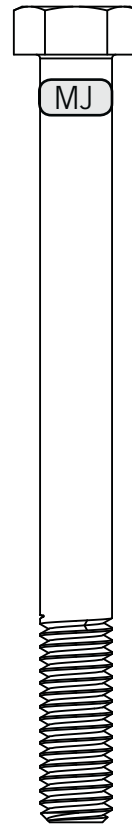
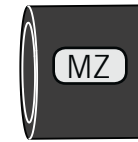
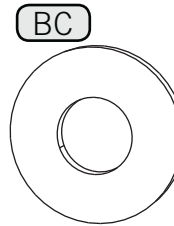
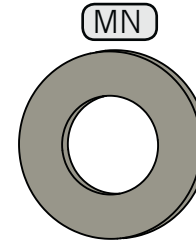
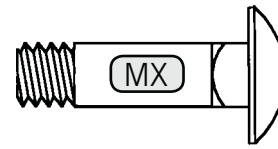
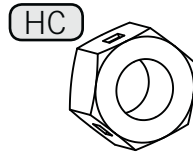



## SAFETY INSTRUCTIONS



**FAILURE TO FOLLOW THESE WARNINGS MAY RESULT IN SERIOUS INJURY OR PROPERTY DAMAGE AND WILL VOID WARRANTY.**

*Owner must ensure that all players know and follow these rules for safe operation of the system.*

To ensure safety, do not attempt to assemble this system without following the instructions carefully. Check entire box and inside all packing material for parts and/or additional instruction material. Before beginning assembly, read the instructions and identify parts using the hardware identifier and parts list in this document. Proper and complete assembly, use and supervision are essential for proper orientation and to reduce the risk of accident or injury. A high probability of serious injury exists if this system is not installed, maintained, and operated properly.

- If using a ladder during assembly, use extreme caution.
- Three capable adults are recommended for this operation.
- Assemble the pole sections properly. Failure to do so could cause the pole sections to separate during play.
- Before digging, contact utility company to locate underground power cables, gas, and water lines. Ensure that there are no overhead power lines within 20 ft. (7m) radius of pole location.
- Minimum operational height is 7'6" (2,23m) to the rim.

***Most injuries are caused by misuse and/or not following instructions. Use caution when using this system.***

### Register your product online at [www.lifetime.com](http://www.lifetime.com).

At Lifetime, we are committed to providing innovative and quality products. While registering, you will have the opportunity to give us your feedback. Your input is valuable to us.

You can also opt-in to receive new product notifications or promotions.

In the unlikely event of a product recall or safety modification, your registration provides the information we need to notify you directly.

Registration is fast, easy, and completely voluntary.

*Maintaining your privacy is our long-standing policy at Lifetime. And you can rest assured that Lifetime will not sell or provide your personal data to other third parties, or allow them to use your personal data for their own purposes.*

We invite you to read our privacy policy at [www.lifetime.com](http://www.lifetime.com)

**REGISTER today!**

## POLE SECTION IDENTIFICATION

Identify the pole sections before beginning assembly. Failure to assemble the pole sections correctly may result in severe personal injury or property damage as described on Page One.

**ONCE THE POLE SECTIONS HAVE BEEN SEATED, THEY CANNOT BE SEPARATED.**



TP

**Top Pole:**

Four holes at the top of the pole, four holes in the middle, two holes near the bottom and one small hole at the bottom.

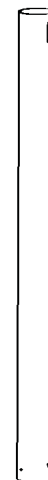

MP

**Middle Pole:**

One slot at the top of the pole and one small hole at the bottom. Warning Sticker.



BP

**Bottom Pole:**

One slot at the top of the pole and a bent edge at the bottom. Shortest pole.

**For a nonpermanent installation of your basketball system, a Ground Sleeve provides an alternative to cementing the pole into the ground. See Page 14 for more information.**

- 1** 1.1 Dig a round hole 24" deep and 18" in diameter. The edge of the hole should be flush with the edge of the playing surface.

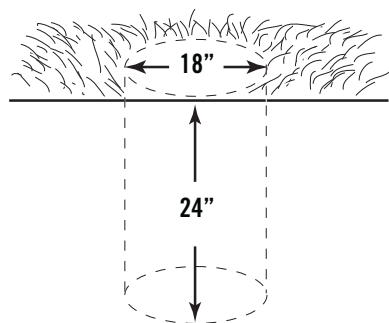

- 1.2 Make a mark 14.5" up from the dimpled end of the Bottom Pole (BP) (do not scratch the powder coating).

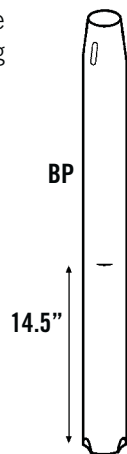

- 3** 3.1 The slots in the Bottom Pole must be parallel to the playing surface. If necessary, insert a straight object (a ruler, wire, etc.) through the slots in the Bottom Pole. Rotate the pole until the straight object is parallel to the playing surface.

**Note:** Form the cement into a downward slope away from the pole to allow water runoff. **Failure to do so may result in premature rusting of the pole.**

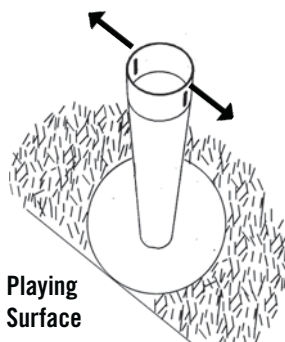

- 4** 4.1 Place the 1/2" x 3' rebar (not included) inside the Bottom Pole (BP).

- 4.2 Check the pole several times within the first hour to make sure that all sides are vertical and that the pole does not sink into the concrete. The 14.5" mark must remain level with the playing surface.

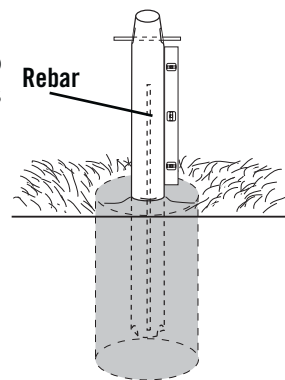

**Important: Allow 1-4 hours for the concrete to set.**

- 2** 2.1 Mix 5 1/2 bags of concrete, following the directions on the concrete bags. Keep in mind that a thicker mix of concrete will dry stronger.

**Important: Save a 1/2 bag of concrete mix to use later in the assembly.**

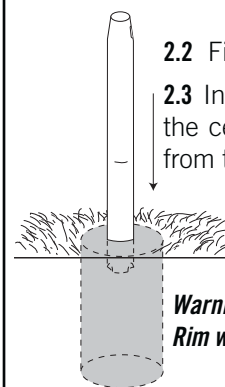

- 2.2 Fill the hole to the top with concrete.

- 2.3 Insert the dimpled end of the Bottom Pole into the cement up to the 14.5" mark and 4" away from the playing surface.

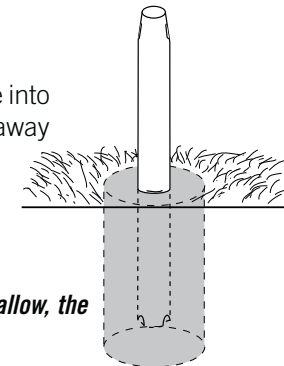

**Warning: If the pole is buried too deep or too shallow, the Rim will not be at the correct height.**

**Important: Do not continue until the concrete has set for 1-4 hours.**

- 5** 5.1 Remove the straight object from the top of the pole.

- 5.2 Mix the remaining 1/2 bag of concrete and pour the concrete into the Bottom Pole until it is just below the slots in the top of the pole.

**Important: Do not overfill the pole, or you may not be able to assemble the rest of the pole sections.**

- 5.3 Tamp the concrete down in the Bottom Pole with a broom handle to remove any air pockets.

- 5.4 Clean all excess concrete off the outside surface of the pole.

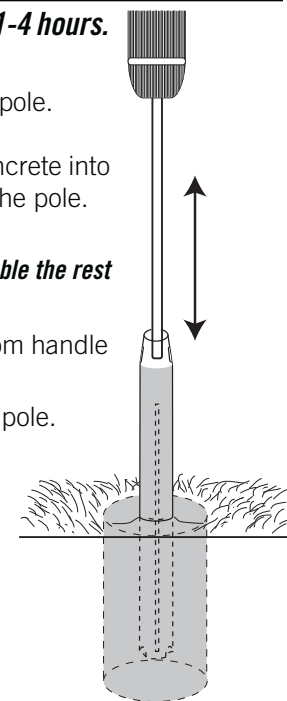

**STOP!**

The concrete must cure for at least **72 hours (3 days)** before installing the rest of the system. In humid climates or wet weather, allow additional time for the concrete to cure. Do not proceed until the curing process is complete.

**Required For This Page:**

9/16" Wrenches



Screwdriver

1039829

HC

(2)

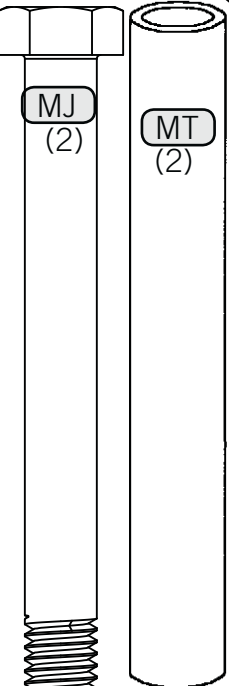
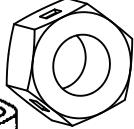

MJ  
(2)

MT  
(2)

BC (2)

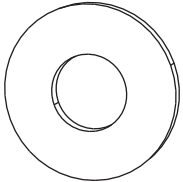

1005748

PA  
(1)

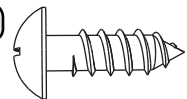

6

**6.1 Completely tighten the Nuts.**

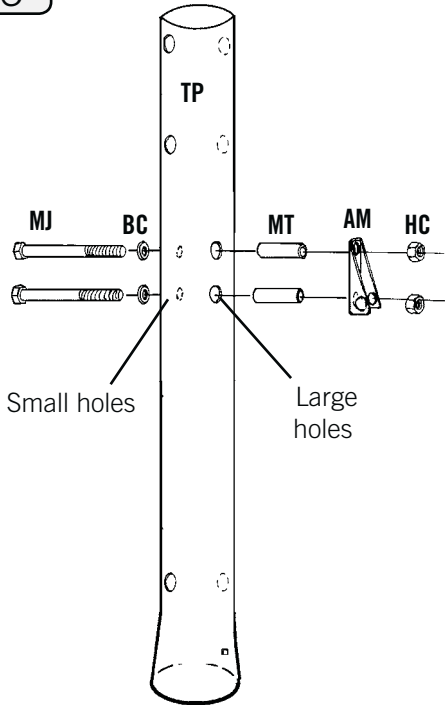

7

**7.1 Apply the Height Sticker (AL) so it wraps around the opposite side of the pole as the Spring Bracket (AM).**

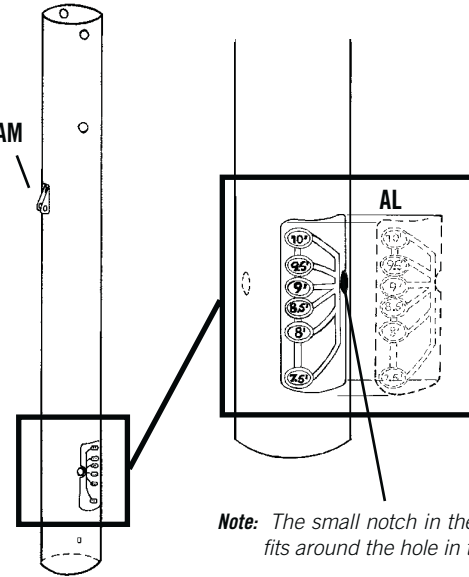

8

**8.1 Align the hole in the Top Pole with the slot in the Middle Pole and slide the Top Pole over the Middle Pole.**

**Do not jam the poles together until instructed.**

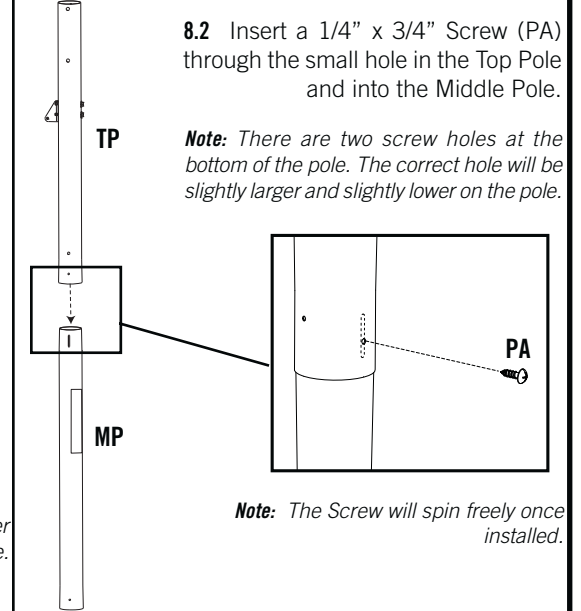

**8.2 Insert a 1/4" x 3/4" Screw (PA) through the small hole in the Top Pole and into the Middle Pole.**

**Note:** There are two screw holes at the bottom of the pole. The correct hole will be slightly larger and slightly lower on the pole.

**This step cannot be reversed.**

9

**9.1 Strike each end of the Pole firmly 5 to 6 times on a piece of scrap wood or cardboard.**

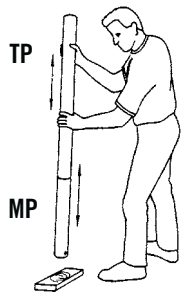

**Warning:** If the Top and Middle Poles do not completely cover the slots on the Middle and Bottom Poles after seating, **DO NOT COMPLETE ASSEMBLY.** Call our Customer Service Department.

**Warning:** Do not hit your feet with the pole sections, as serious injury could occur.



**WARNING**



The poles must be seated together!! Even if the poles cover the slots before seating, you must strike them on the wood five to six times!! Failure to seat the poles correctly could allow the poles to separate during use, which could lead to serious personal injuries or property damage as listed on Page One.

10

**10.1 The bottom of the Bellows (AS) overlaps the Gas Spring (AN) by 1". The top is 1/2" from the top of the Spring.**

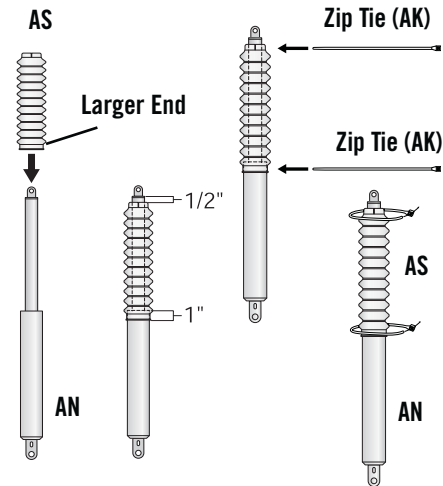

**10.2 Use pliers to tighten the Zip Ties (AK) securely. Cut off the ends of the Zip Ties.**

**Required For This Page:**



1017923

- 1/2" Wrenches
- 9/16" Wrenches
- 3/4" Wrenches
- Scissors/
- Wire Cutters/
- Pliers
- Hammer/
- Mallet

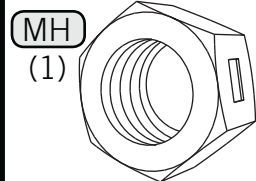

**MH**  
(1)

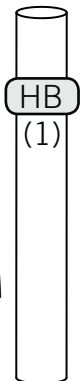

**HB**  
(1)

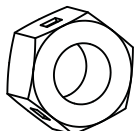

**HC**  
(2)

1039829

**MO** (2)



**MD**

(1)\*

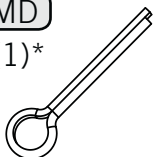

**ME**

(1)\*

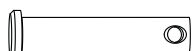

\*(Not actual size)

**HD** (1)

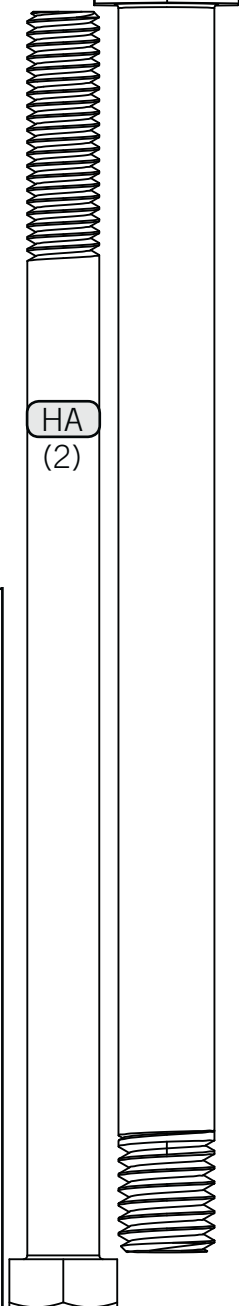

**HA**  
(2)

**11** 11.1 Line up the Rear Lifter Arms (AR) with the Gas Spring (AN).  
11.2 Tighten the Nut until it is flush with the Bolt.

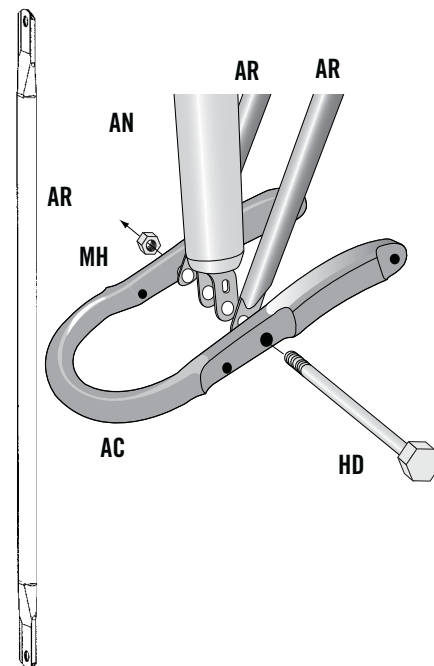

**12** 12.1 Use pliers to bend the Cotter Pin (MD) as shown above.

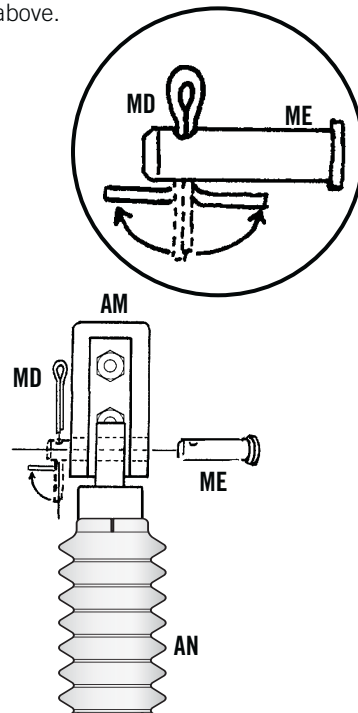

**13** 13.1 Tighten the Nut until it is flush with the Bolt.

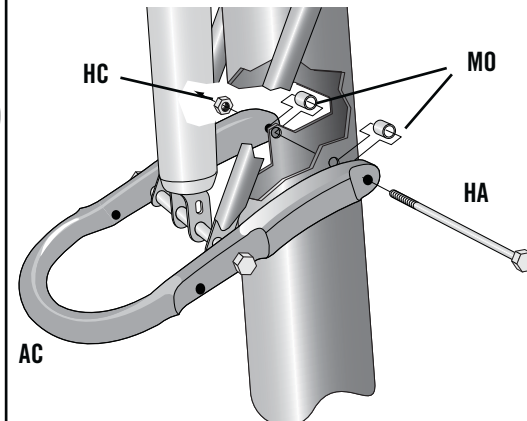

**14** 14.1 Slide the Release Pin (HB) through the oval holes of the clevis at the end of the Gas Spring (AN).

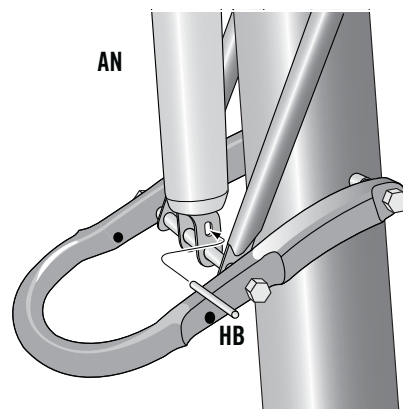

**15** 15.1 The Release Pin (HB) should fit into the channels in the Trigger (AD).

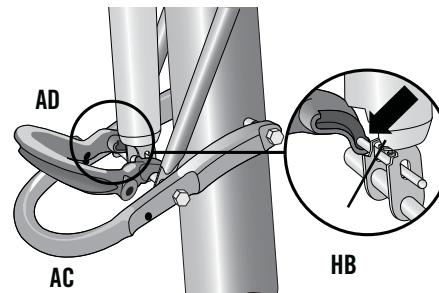

**16** 16.1 Tighten the Nut (HC) until it is flush with the Bolt.

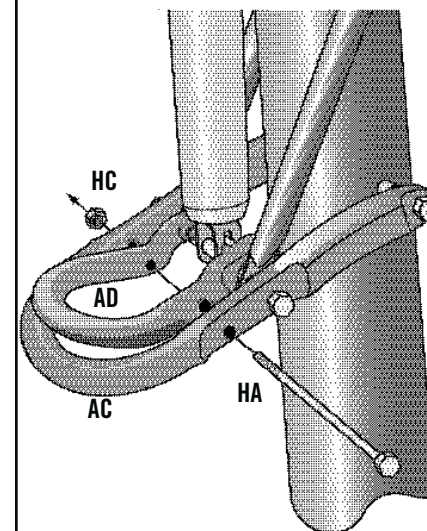

**Required For This Page:**



9/16" Wrenches

Pliers

1/2" Socket Wrench

1003678

RB (2)

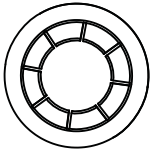

RC (2)

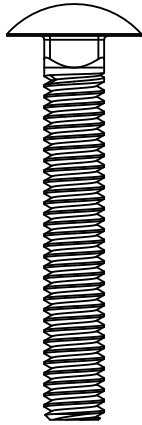

RI (1)



(Not actual size)

1039829

MB (2)

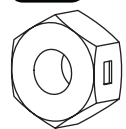

ML (2)



**17** 17.1 Hold the Backboard Brackets (AP & AQ) together and slide the U-Bolt (RE) through the holes as shown.

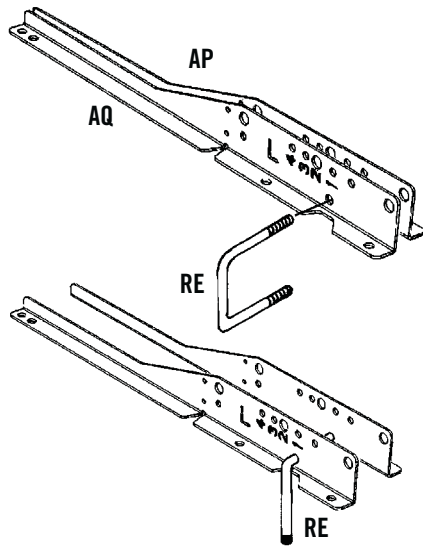

**18** 18.1 Ensure the U-Bolt (RE) is in the notches.

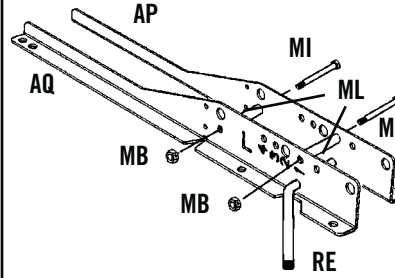

18.2 Completely tighten the Nuts (MA).

**19** 19.1 Insert a 5/16" x 2" Carriage Bolt (RC) through each hole in the Rim Pivot Bracket (RI).

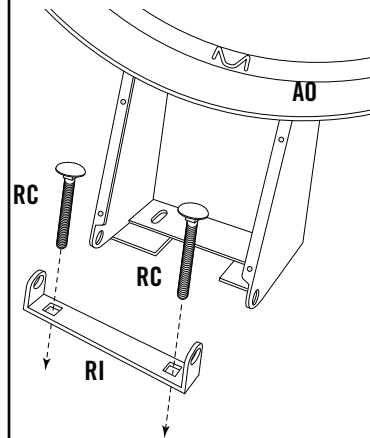

**20** 20.1 Use the 1/2" socket head from the socket head wrench to press one Push Nut (RB) onto one end of the Axle (RH).

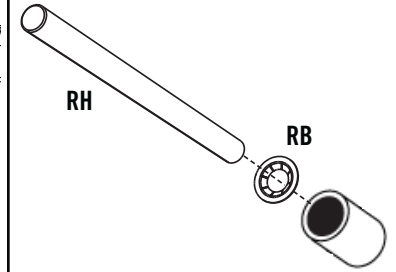

*Note: The Push Nut should rest about 1/4" from the end of the Axle. If the Push Nut slips on too far, continue sliding it to the other end of the Axle to remove it and try again.*

**21** 21.1 Slide the end of the Axle (RH) through the Rim (AO) and the Rim Pivot Bracket (RI). Press the Push Nut (RB) onto the end of the Axle. Use the 1/2" socket head to secure the Push Nut if needed.

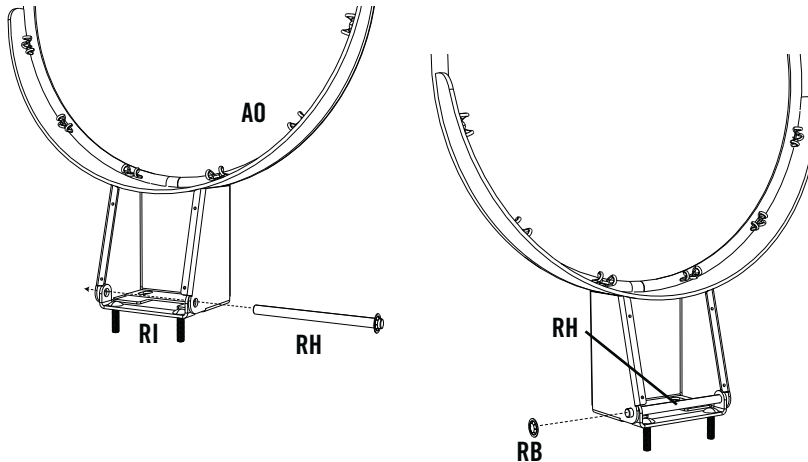

**22** 22.1 Lay the Backboard (AU) on a table or bench.

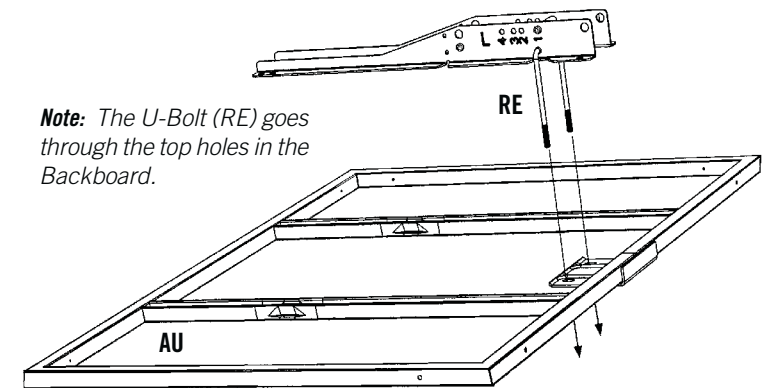

*Note: The U-Bolt (RE) goes through the top holes in the Backboard.*



**Required For This Page:**

-  1/2" Wrench
- 3/4" Wrenches
- Electric Drill/
- Screwdriver
- 1003678

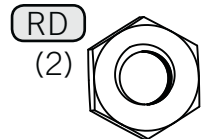

RJ (1)



(Not actual size)

1039829

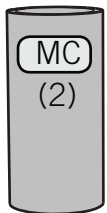

**23** 23.1: Slide a Spacer (MC) over each Tap Bolt (RC) between the Backboard and the Backboard Brackets.

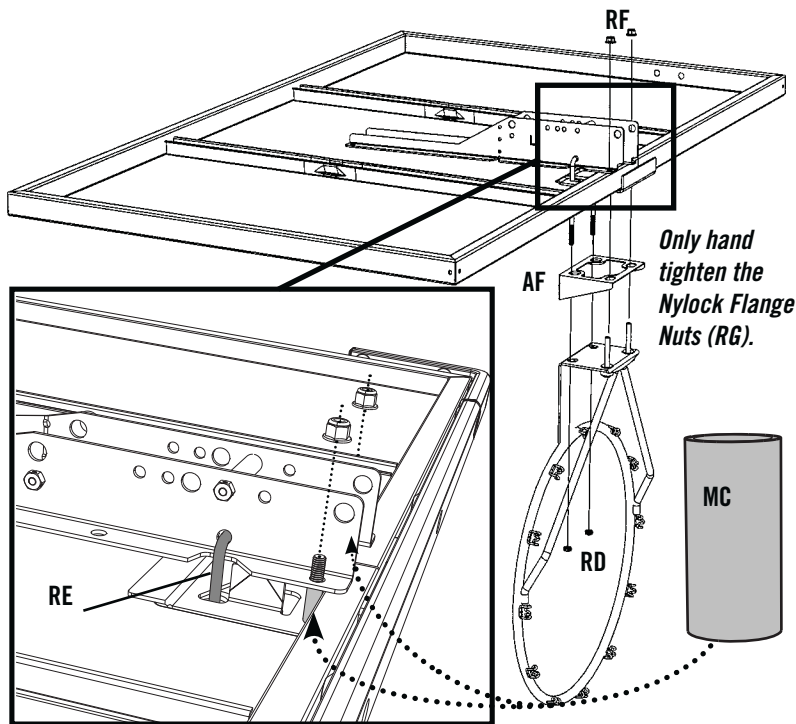

**24** 24.1 Place the Compression Springs (RG) over the ends of the U-Bolt (RE).

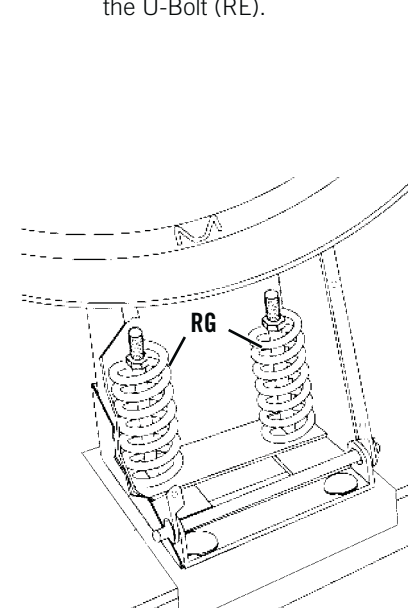

**25** 25.1 Place the Spring Retainer Plate (RJ) and secure with Nylock Flange Nuts (RF).

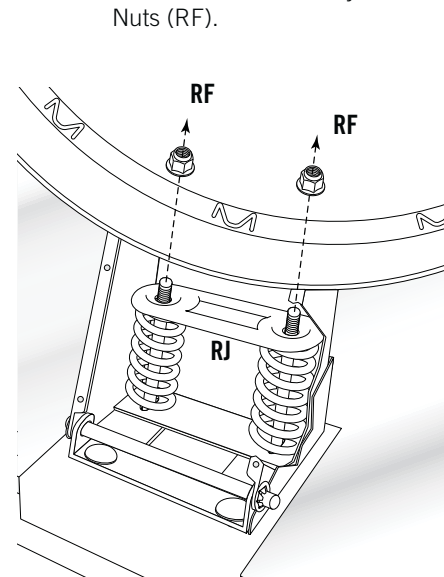

**Note:** Do not overtighten the Nuts (RF).

**26** 26.1 Slide a Carriage Bolt (MX) into the crimped slot in each Backboard channel.

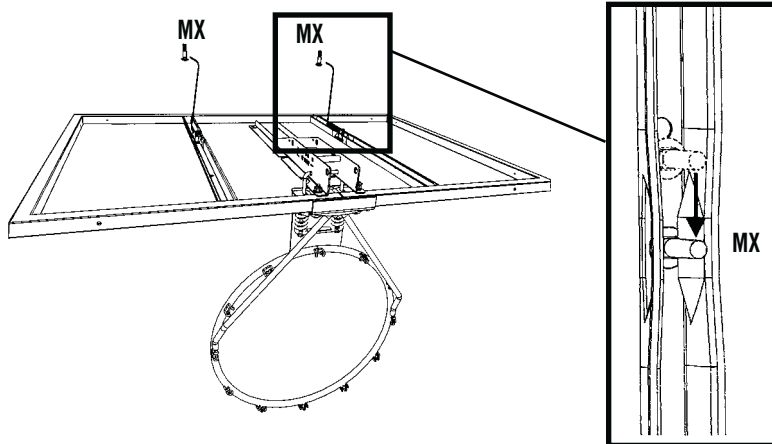

**27** 27.1 Attach the Rim Cover Plate (AX) to the Rim using #7 x 3/8" Screws (RA).

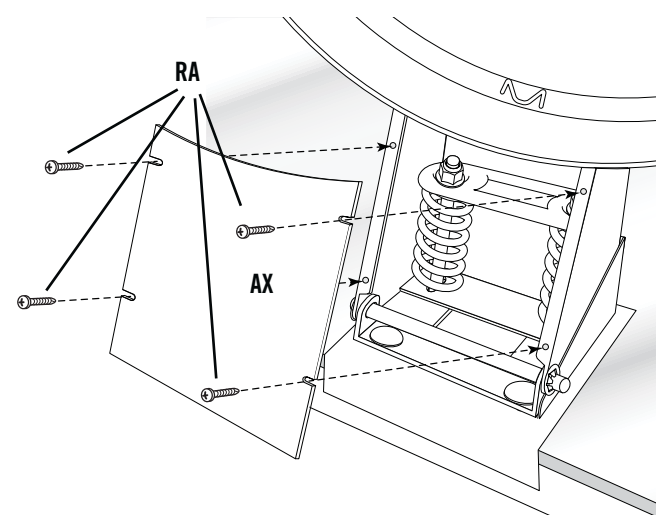

Required For This Page:



1/2" Wrench  
3/4" Wrenches

1039829

**MH**

(2)

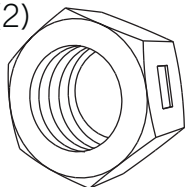

**MZ**

(4)

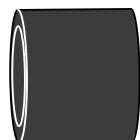

**MX**

(2)

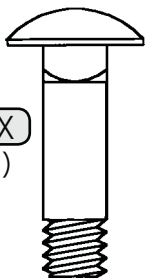

**MY**

(2)



**MA**  
(2)



**28**

**28.1** Bend the Backboard Brackets (AP & AQ) out and over the Carriage Bolt (MX).

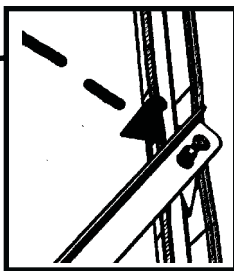
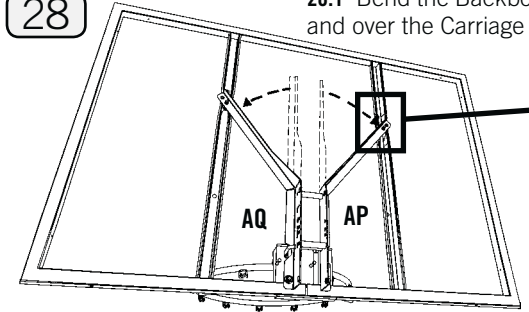

*Note:* The lower holes should go over the Carriage Bolts.

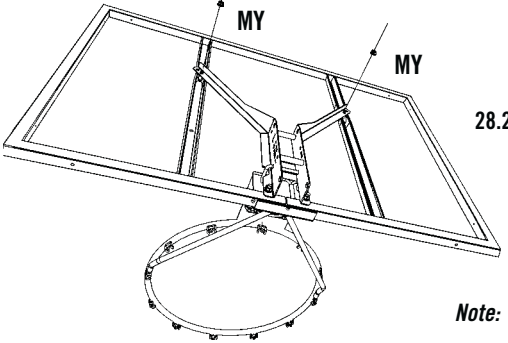

**28.2** Secure Brackets with 5/16 " Nylock Flange Nuts (MY).

**28.3** Completely tighten all Rim hardware.

*Note:* Do not overtighten the Nuts (MY).

**29**

**29.1** Tighten the Nut until it is flush with the Bolt.

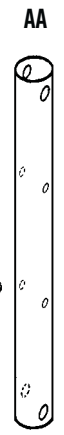
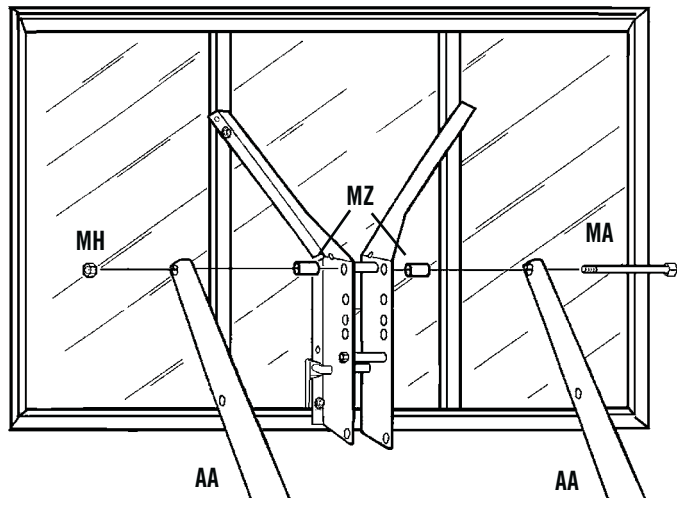

**30**

**30.1** Attach this end of the Long Extension Arms (AE) to the Backboard Brackets (AP & AQ).

**30.2** Tighten the Nut until it is flush with the Bolt.

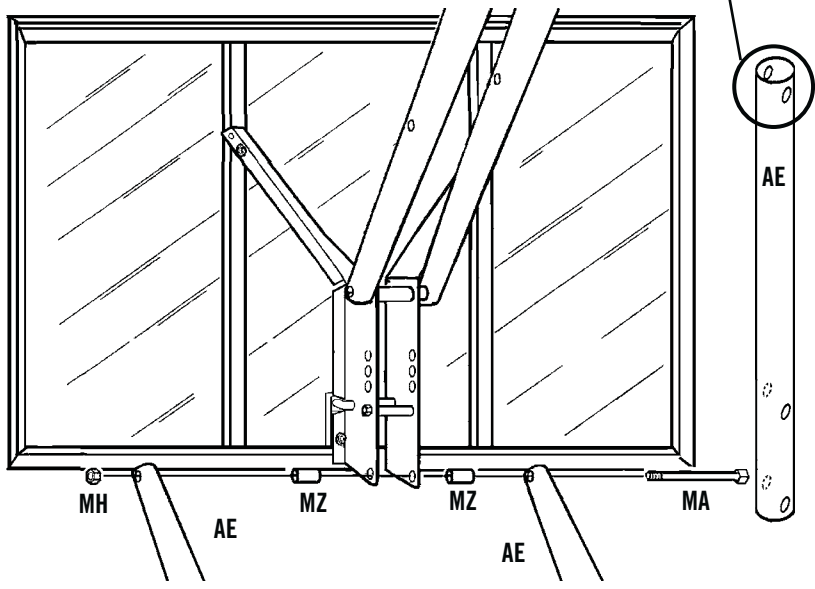

**31**

**31.1** Rest the Backboard (AU) and Rim (AO) on cardboard to prevent scratching.

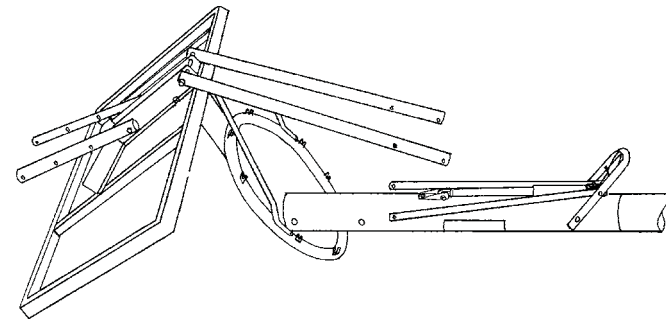

**Required For This Page:**  
3/4" Wrenches

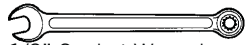

1/2" Socket Wrench

Hammer/Mallet

Electric Drill

1039829

**MN**  
(4)

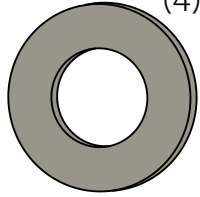

**MR**  
(1)

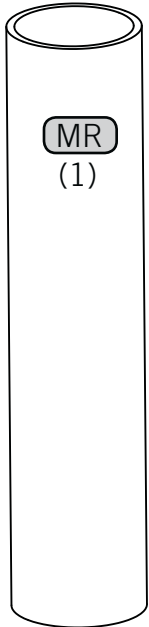

**MH** (3)



HH00700

**FA** (10)

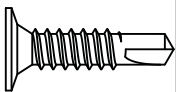

**MA**  
(3)

**32** 32.1 Remove the plastic film from the Backboard.

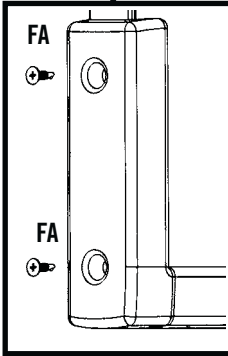
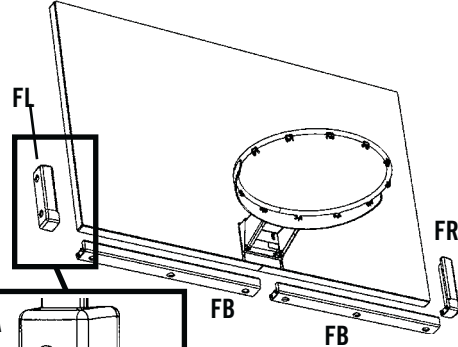

32.2 Use an electric drill to insert the Screws (FA).

**33** 33.1 Lift the pole up until the Long Extension Arms (AE) line up with the holes in the Rear Lifter Arms (AR).

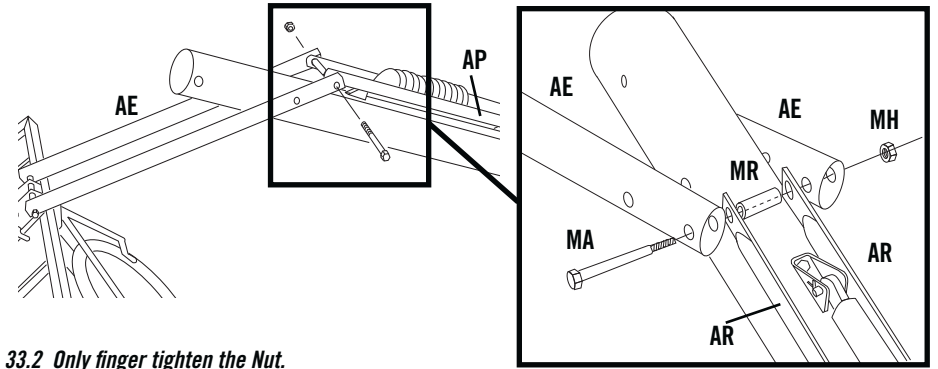

33.2 Only finger tighten the Nut.

**Note:** The Rear Lifter Arms (AR) must be on the inside of the Extension Arms (AE).

**34** 34.1 There must be a 1/2" x 1/8" Spacer (MN) between each Long Extension Arm (AE) and the pole.

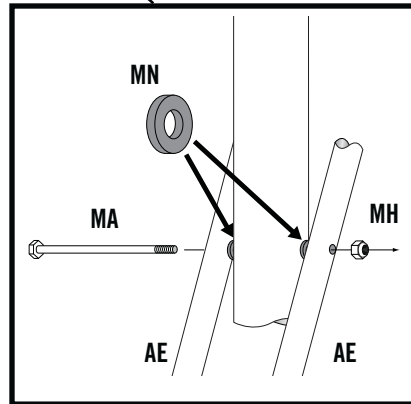
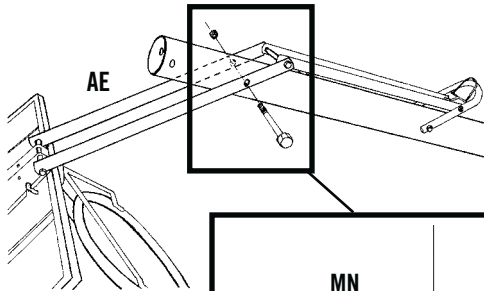

34.2 Only finger tighten the Nut.

**35** 35.1 Place a 1/2" x 1/8" Spacer (MN) between each Short Extension Arm (AA) and the pole.

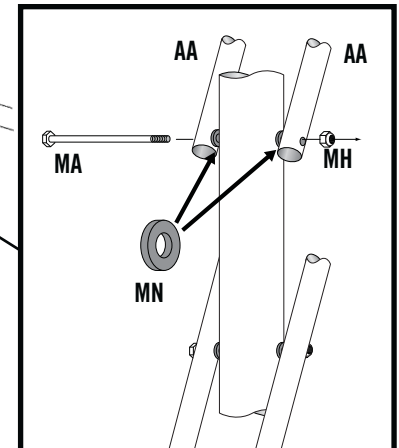
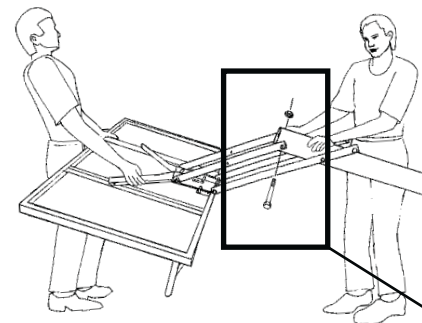

35.2 Completely tighten the Nuts from steps 33 through 35.

**36** 36.1 Attach the Net (AB).

**Note:** Please call our Customer Service Department at the number on Page One to obtain replacement Nets. Our Nets are shorter than average to reduce the risk of entanglement.

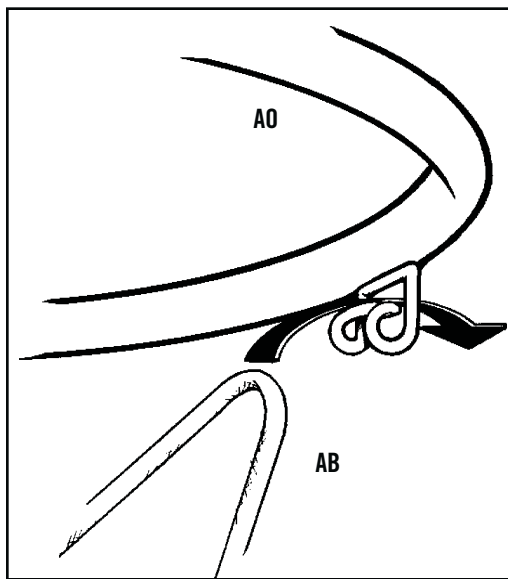

**37** 37.1 Apply the Grease (MQ) to these areas.

**CAUTION:** DO NOT APPLY EXCESSIVE WEIGHT TO THE HANDLE. Do not hang anything from the Handle, as this will damage the system and void the product warranty.

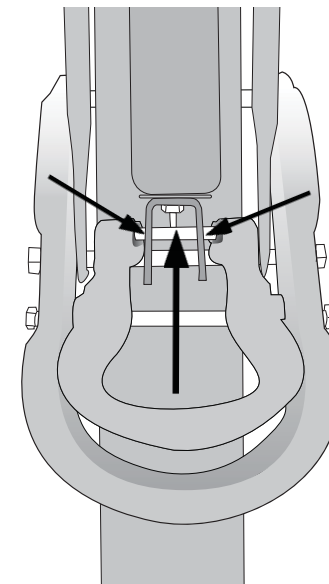

**38** 38.1 Slowly lift the pole and rotate the Backboard assembly upside down again.

**38.2** Grasp the Handle and Trigger as shown. Squeeze the Trigger and push down on the pole to compress the Gas Spring.

**38.3** Release the Handle before letting go of the pole.

**CAUTION:** When compressing the Gas Spring, use extreme caution to prevent the pole from extending.

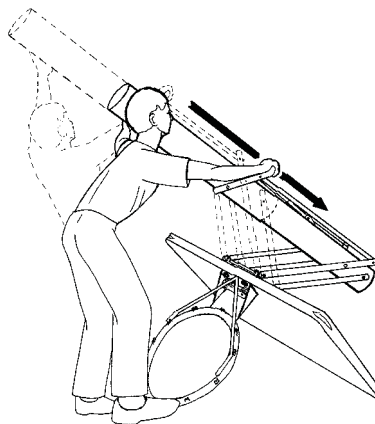

**Required For This Page:**

Screwdriver  
 Hammer/Mallet  
 Electric Drill  
 1005748

**\*\*AT LEAST 2 ADULTS REQUIRED FOR THIS STEP\*\***

**39** **39.1** Ensure the Backboard faces the playing surface and align the small hole in the Middle Pole (MP) with the correct slot in the Bottom Pole (BP). Slide the Middle Pole over the Bottom Pole.

**39.2** Insert the remaining 1/4" x 3/4" Screw (PA) through the small hole in the Middle Pole and into the Bottom Pole. The Screw will spin freely once installed.

*Note:* There are two screw holes at the bottom of the pole. The correct hole will be slightly larger and slightly lower on the pole.

**39.3** Place the Wood Block (AJ) on top of the pole and strike with a hammer six or seven times.

**Warning:** If the Middle Pole does not completely cover the slot on the Bottom Pole after seating, DO NOT COMPLETE ASSEMBLY. Call our Customer Service Department.

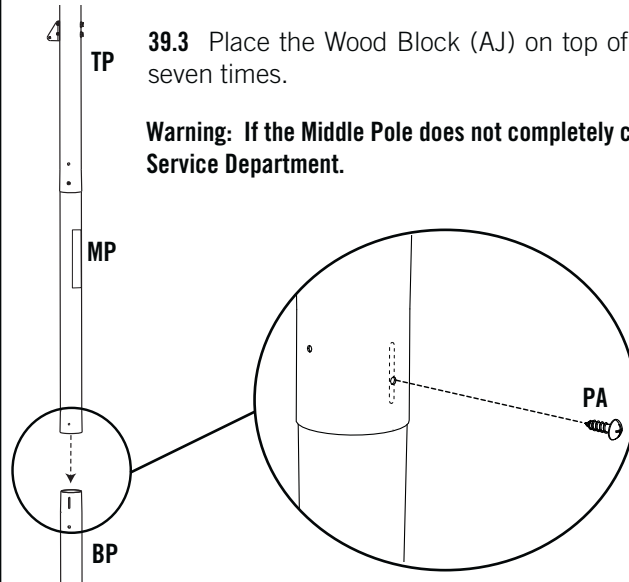

**39.4** Place a Self-tapping Screw (PB) directly into the chuck of the Electric Drill and insert the screw into the back of the poles at the locations shown.

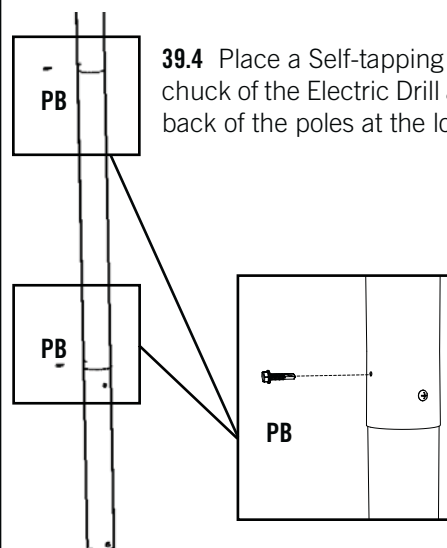

**39.5** After setting the poles in step 39.3, Insert the Pole Cap (AW) into the pole.

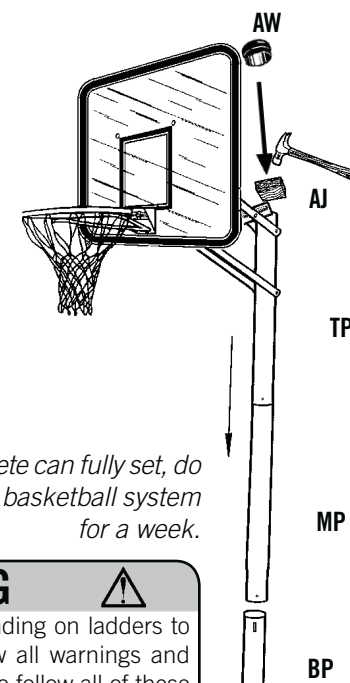

*Note:* To ensure that the concrete can fully set, do not play aggressively on your basketball system for a week.

**WARNING**

Use extreme caution when standing on ladders to perform assembly steps. Follow all warnings and cautions on the ladder. Failure to follow all of these instructions and warnings could lead to serious personal injury or property damage.

## Operation of the height adjustment system

The adjustable system may be adjusted from 7 1/2 feet to 10 feet.

Hold the Handle tightly and squeeze the Trigger to engage the Gas Spring. Raise the Handle to lower the Backboard, or lower the Handle to raise the Backboard.

**WHILE TRANSPORTING THE PORTABLE SYSTEM, USE CAUTION TO PREVENT THE MECHANISM FROM ADJUSTING.**

## Moving the system

**⚠ WARNING: The system must only be moved by people capable of handling its weight. Children should not be allowed to move the system. ⚠**

- Adjust the system to its lowest position.
- Stand in front of the system and pull on the pole until the unit is balanced on its Wheels.
- Move the system to the desired location and carefully set the Base down.

## POLE CARE AND SYSTEM MAINTENANCE

The life of your basketball system depends on many variables. The climate, exposure to corrosives such as salt, pesticides, or herbicides, and excessive use or misuse can all contribute to pole failure, which may cause property damage or personal injury.

Check your basketball system frequently for loose hardware, excessive wear, and signs of corrosion. For safety reasons, and to prolong the life of your basketball system, you **must** take the following preventive measures.

- Check all Nuts and Bolts. If any are loose, tighten them.
- Check all parts for excessive wear and tear. If necessary, replace any parts that have been worn or damaged through usage. Check the Pole Cap for cracks or tears that could let water into the pole. Contact our Customer Service Department for replacement parts.
- Inspect the Warning Sticker on the pole. If it is ripped, faded, or illegible, call our Customer Service Department to request a replacement Sticker.
- Check all pole sections for visible rust or chipped or cracked paint. If either are present, do the following:
  - Use an emery cloth to completely remove any rust or chipped paint.
  - Clean the area with a damp cloth and allow it to dry.
  - Apply two coats of a rust preventative, high gloss enamel paint to the area. Allow the paint to dry between coats.

**IF RUST HAS PENETRATED THROUGH THE POLE ANYWHERE, REPLACE IT IMMEDIATELY!**

## ACCESSORIES AVAILABLE FOR MORE BASKETBALL FUN!

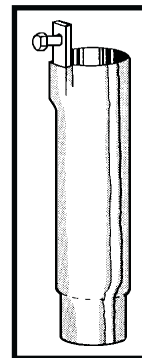

PRODUCT DESCRIPTION	MODEL #	_____
Size Basketball	594201	Universal Ground
Sleeve	0023	

Contact Customer Service at the number on Page Two for prices and freight cost.

### Universal Ground Sleeve #0023

The Universal Ground Sleeve enables the pole to be cemented in, yet still removable. The sleeve sits flush with the ground after installation. Fits 3.5" diameter poles.

**Only clean the Backboard with the approved cleaning materials listed below:**

Windex <sup>1</sup>	Fantastik <sup>3</sup>
Joy <sup>2</sup>	Formula 409 <sup>4</sup>
Mr. Clean <sup>2</sup>	

**The use of other chemicals will void the warranty.**

<sup>1</sup>Registered Trademark of the Drackett Products Company.

<sup>2</sup>Registered Trademarks of Procter & Gamble.

<sup>3</sup>Registered Trademark of Texize, Division of Norton Norwich Products Inc.

<sup>4</sup>Registered Trademark of the Clorox Company.



## WARNING



### FAILURE TO FOLLOW THESE WARNINGS MAY RESULT IN SERIOUS INJURY AND/OR PROPERTY DAMAGE.

Owners must ensure that all players know and follow these rules for safe operation of the system.

- Only hang from the rim briefly to regain balance or avoid injuring others. Release the rim as soon as safely possible.
- During play, especially when performing dunk type activities, keep player's face away from the backboard, rim, and net. Serious injury could occur if teeth/face come in contact with the backboard, rim, or net. Player should wear a mouth guard during play.
- Do not slide, climb, or play on pole.
- When adjusting height or moving system, keep hands and fingers away from moving parts.
- Do not allow children to move or adjust system.
- Do not wear jewelry (rings, watches, necklaces, etc.) during play. Objects may entangle in net.

- Keep organic material away from pole base. Grass, litter, etc. could cause corrosion and/or deterioration.
- Once a month check pole and all metal parts for signs of corrosion (rust, pitting, chipping). Completely remove rust and repaint with exterior enamel. If rust has penetrated any steel part, replace that part immediately.

- Check system before each use for loose hardware, excessive wear, instability, and signs of corrosion and repair before use.
- Never play on damaged equipment.
- Do not use the system to lift or hoist anything. The mechanism is designed to lift only the weight of the backboard and rim. Do not hang anything from the handle, rim backboard, or lifter arms as this will damage the system and void the warranty.

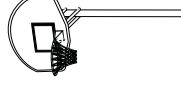

## ADVERTENCIA



### SI NO SE OBEDECEN ESTAS ADVERTENCIAS PUEDEN PRODUCIRSE GRAVES LESIONES Y/O DAÑOS A LA PROPIEDAD.

El propietario del sistema debe asegurarse de que todos los jugadores conozcan y respeten estas reglas para que el sistema se use en forma segura.

- Cuélguese del aro sólo en forma breve, para recuperar el equilibrio o evitar lesionar a otros jugadores. Suéltese del aro lo más pronto que pueda hacerlo con seguridad.
- Durante el juego, especialmente al embocar violentamente de alto, la cara de los jugadores debe mantenerse alejada del tablero, el aro y la red. Pueden producirse lesiones graves si los dientes o la cara entran en contacto con el tablero, el aro o la red. Los jugadores deben usar un protector bucal durante el juego.
- No se deslice, no trepe ni juegue sobre el poste.
- Mantenga las manos y los dedos alejados de las piezas móviles cuando regule la altura del sistema.
- No deje que los niños regulen el sistema.
- No use joyas (anillos, relojes, collares o gargantillas, etc.) durante el juego. Estos objetos pueden engancharse en la red.
- No permita que la base del poste entre en contacto con materiales orgánicos. El pasto, los desechos animales, etc., pueden causar corrosión y/o deterioros.
- Controle el poste y todas las piezas metálicas una vez al mes en busca de signos visibles de corrosión (oxidación, picaduras, escamado). Elimine todo rastro de óxido y vuelva a pintar con esmalte para exteriores. Si el óxido ha penetrado cualquier pieza de acero, reemplace esa pieza de inmediato.
- Inspeccione el sistema antes de cada uso para verificar que los elementos de fijación no estén flojos, que no haya desgaste excesivo, inestabilidad ni signos de corrosión. Si encuentra irregularidades, repárelas antes de usar el sistema.
- Nunca juegue con un equipo dañado.
- No use el sistema para levantar ningún objeto. El mecanismo está diseñado para elevar solamente el peso del tablero con el aro. No cuelgue nada de la agarradera, el aro, el tablero ni los brazos de elevación, ya que esto puede dañar el sistema y anular la garantía.

#FS16500 10/12/2004



## AVERTISSEMENT

### FAUTE DE NE PAS SUIVRE CES AVERTISSEMENTS, VOUS RISQUEZ DE CAUSER DES BLESSURES GRAVES ET/OU DES DOMMAGES À L'ÉQUIPEMENT.

Le propriétaire doit s'assurer que tous les joueurs connaissent et appliquent les règles suivantes afin d'utiliser l'équipement en toute sécurité.

- Ne vous suspendez pas à l'anneau plus que nécessaire pour retrouver votre équilibre ou éviter de blesser les autres joueurs. Relâchez l'anneau aussitôt que possible.
- Lors d'un match, particulièrement dans le cas des smashes, le visage du joueur ne doit pas faire face au panneau, à l'anneau, ni au filet. Le joueur risque de graves blessures si ses dents ou son visage entrent en contact avec le panneau, l'anneau, ou le filet. Les joueurs doivent toujours porter un protège-dents lorsqu'ils jouent.
- Ne glissez pas, ne grimpez pas, et ne jouez pas sur la base ou le poteau.
- Lorsque vous ajustez la hauteur ou l'équipement, gardez vos mains et doigts loin des pièces mobiles.
- N'autorisez pas les enfants à ajuster l'équipement.
- Ne portez pas de bijoux (bagues, montres, colliers, etc.) lorsque vous jouez. Ces objets pourraient s'accrocher au filet.
- Gardez la base du poteau libre de toute matière organique. L'herbe, les déchets, etc. peuvent la corroder et la détériorer.
- Une fois par mois, vérifiez que le poteau et toutes les pièces en métal ne montrent pas de signes de corrosion (rouille, piqûres, écaillage). Enlevez toute la rouille et repeignez complètement avec une peinture pour extérieur. Si la rouille a pénétré une des pièces en acier, vous devrez remplacer immédiatement la pièce en question.
- A chaque fois que vous allez utiliser l'équipement, vérifiez d'abord l'équilibre, la possibilité de pièces desserrées ou usées, la stabilité de l'équipement et tout signe de corrosion ou réparation nécessaire avant utilisation.
- Ne jouez jamais avec un équipement endommagé.
- N'utilisez pas l'équipement pour lever ou soulever quoique ce soit. Son mécanisme a été conçu uniquement pour soutenir le poids du panneau et de l'anneau. N'accrochez rien au manche, à l'anneau, au panneau ni aux leviers sous peine d'endommager l'équipement et d'annuler la garantie.

[www.lifetime.com](http://www.lifetime.com)

# LIFETIME BASKETBALL EQUIPMENT 5-YEAR LIMITED FACTORY WARRANTY

THE MANUFACTURER RESERVES THE RIGHT TO MAKE SUBSTITUTIONS TO WARRANTY CLAIMS IF PARTS ARE UNAVAILABLE OR OBSOLETE.

1. Lifetime basketball systems are warranted to the original purchaser to be free from defects in material or workmanship for a period of five years from the date of original retail purchase. The word “defects” is defined as imperfections that impair the use of the product. Defects resulting from misuse, abuse or negligence will void this warranty. This warranty does not cover defects due to improper installation, alteration or accident. This warranty does not cover damage caused by vandalism, rusting, “acts of nature” or any other event beyond the control of the manufacturer.
2. This warranty is nontransferable and is expressly limited to the repair or replacement of defective basketball equipment. If the equipment is defective within the terms of this warranty, Lifetime Products, Inc. will repair or replace defective parts at no cost to the purchaser. Shipping charges to and from the factory are not covered and are the responsibility of the purchaser. Labor charges and related expenses for removal, installation or replacement of the basketball system or its components are not covered under this warranty.
3. This warranty does not cover scratching or scuffing of the product that may result from normal usage. In addition, defects resulting from intentional damage, negligence, unreasonable use or hanging from the net or rim will void this warranty.
4. Liability for incidental or consequential damages is excluded to the extent permitted by law. While every attempt is made to embody the highest degree of safety in all equipment, freedom from injury cannot be guaranteed. The user assumes all risk of injury resulting from the use of this product. All merchandise is sold on this condition, and no representative of the company may waive or change this policy.
5. This product is not intended for institutional or commercial use; Lifetime Products, Inc. does not assume any liability for such use. Institutional or commercial use will void the warranty.
6. This warranty is expressly in lieu of all other warranties, expressed or implied, including warranties of merchantability or fitness for use. Neither Lifetime Products, Inc., nor any representative assumes any other liability in connection with this product.



**ALL WARRANTY CLAIMS MUST BE ACCOMPANIED BY A SALES RECEIPT.  
REPORT PRODUCT DEFECTS IN WRITING TO:**

Lifetime Products, Inc., PO Box 160010 Clearfield, UT 84016-0010  
or call (800) 225-3865 M-F 7 a.m. to 5 p.m. MST.

Please include your dated sales receipt and photographs of damaged parts.

**To Register Your Product, Visit Our Website at [www.lifetime.com](http://www.lifetime.com)**