



Assembly Book
Revised August 21, 2024



the Hampton

Building Size
12' x 20'

Manufactured by RBS Holdings, LLC

205 Arlington Drive

Greenville, PA 16125

This manual is copyrighted. Under the copyright laws, this manual may not be copied, in whole or in part, without consent from RBS Holdings, LLC © Copyright 2022

IMPORTANT INFORMATION ABOUT YOUR KIT

Thank you for purchasing our kit. Please read the following information before beginning construction. Always check with your local HOA or building code office for any requirements or restrictions.

Inventory all items received within 30 days of delivery.

Should there be missing items or sub-par material contact Best Barns Customer Service. Best Barns cannot guarantee replacement of items beyond 30 days notification.

Floor: Wood flooring is sold optionally. You may choose to build your own or pour a cement pad.

Always wear safety glasses when cutting or nailing!

| | | | |
|-----------------|----------------------|-----------------|-----------------------|
| Tools Required: | Hand or Circular Saw | Level | Safety Glasses |
| | Cordless Drill | Measuring Tape | Dust Mask |
| | Hammer | 6'-8' Ladder(s) | Screwdriver with Bits |
| | Pencil | | Framing Square |

Additional Materials - **Not included in kit:**

Required: Shingles or metal roofing, Drip Edge, Roofing Nails or Screws, Paint, Class 25 Sealant

Optional: Caulk, Ridge Vent

Terminology:

Square - Confirm corners are at 90 degrees
Plumb - Confirm walls and trusses are straight vertically
Wall Plate - Top and bottom 2x4s used to frame walls
Tie Plate - 2x4s connecting wall sections together
Header - Spans top of door opening
OSB - Oriented Strand Board
LAP - Edge of siding that overlaps Tongue
Tongue - Edge of siding that is overlapped

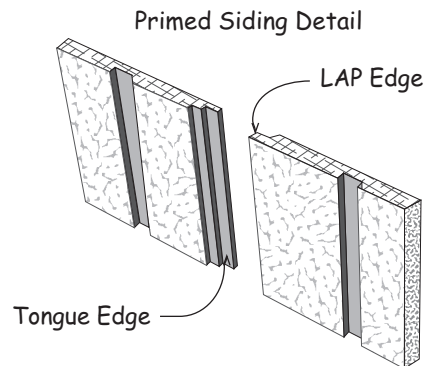

Organize:

Unpack all items & organize according to size and type. This will make items easier to find when instructed. If you are not immediately building the kit stack items tightly to prevent lumber from warping. Cover to protect from the elements.

DO NOT discard any material including the pallet until your project is complete.

Assembly:

Review all instructions before you begin. Please follow steps carefully and in sequence for successful results.

If you have any questions we are happy to assist you. Please contact us at:

800-245-1577 - Mon - Fri 8AM - 5PM EST

724-866-4357 - After hours and weekends

Email - help@barnkits.com

Details for Optional Deluxe Floor System

Foundation size is 12'-0" x 20'-0". Check local building codes in your area, the construction may have to change. For a concrete slab, install sill sealer as a moisture barrier between the concrete and the wall plates. Foam sill sealer can be purchased at home centers in rolls 3-1/2" or wider.

1. Stagger the 4x4 timbers as shown below. Cut (2) two 2x4- 8' boards into 2' long blocks to secure the 4x4s where they butt together.

2. Cut (2) two 2x4-8' to a length of 8' -0". They will be used for the joist headers. Layout, from left, for 16" on center joist spacing. 'X' marks where floor joist will be placed.

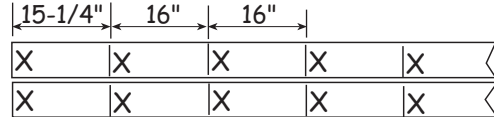

3. Cut (17) seventeen 2x4-12' treated boards to 11' -9". These will be the floor joists. *Treated lumber may be thicker than 1-1/2"*. Take this into account when cutting the length of floor joists. *Shorten joist measurements if necessary to obtain 12'-0" building width.*
4. Install the floor joists cut above between the 8' joist headers. Secure with 16d galv. deck nails.
5. Place floor assembly over the 4x4s. Square floor assembly. Measure the floor diagonally (corner to corner) and then the opposite corners; these measurements will be the same when the floor is square. Toenail frame (headers & joists) to the 4x4 runners.

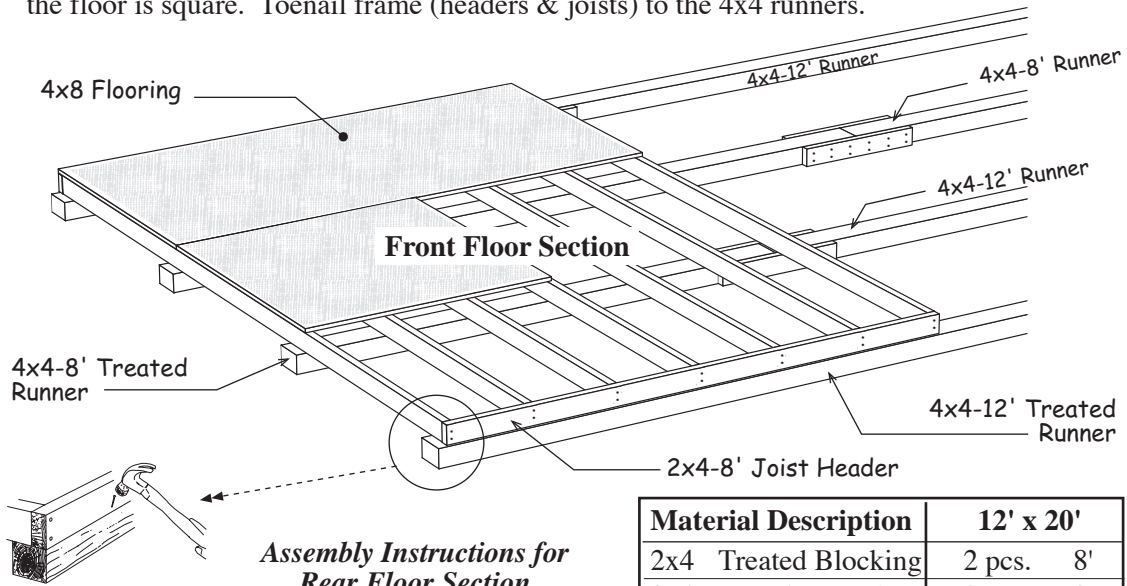



6. Cut (2) two 2x4-12' to a length of 12' -0". Layout for 16" joist spacing, *See above.*
7. Install floor joists between the joist headers. Square the floor section and install against the section assembled above. Toenail to the 4x4s runners.
8. Install 4x8 flooring over the 2x4s. Use 8d galv. spiral nails spaced 8" apart.

| Material Description | 12' x 20' |
|-------------------------|-------------|
| 2x4 Treated Blocking | 2 pcs. 8' |
| 2x4 PT Joist Headers | 2 pcs. 8' |
| 2x4 PT Joist Headers | 2 pcs. 12' |
| 2x4 PT Floor Joist | 17 pcs. 12' |
| 4x4 Treated Runners | 4 pcs. 8' |
| 4x4 Treated Runners | 4 pcs. 12' |
| Flooring 5/8" or 3/4" | 8 pcs. 4x8 |
| Galv Spiral Floor Nails | 3 lb. 8d |
| Galvanized Deck Nails | 5 lb. 16d |

Step 1 Assemble 12' Back Wall

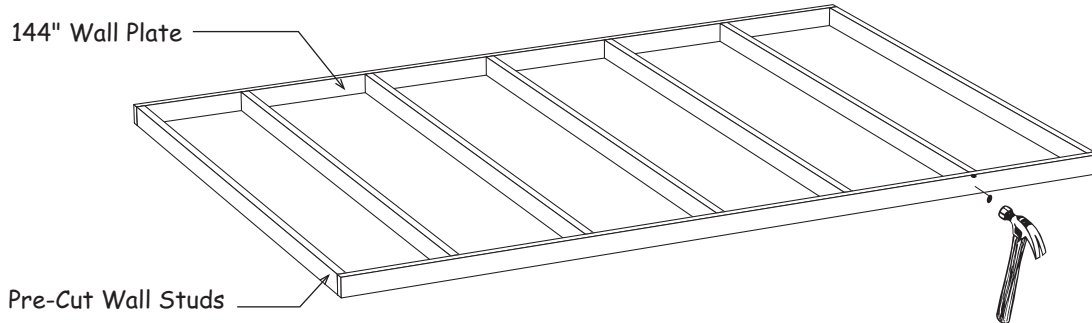
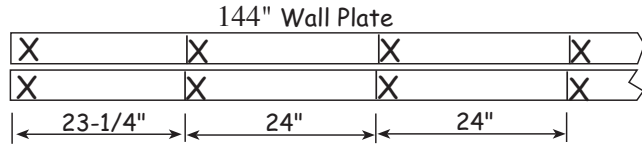
1. Cut (2) two 2x4-12' to a length of 144". Position the boards together and indicate with 'X' marks where the wall studs will be located.



 Depending on your location pre-cut wall studs vary in length from 92-1/4" to 93". This doesn't affect construction.

2. Install (7) seven pre-cut wall studs between the top & bottom plates. Nail studs to wall plates with 10d sinkers, (2) two nails on each end.
3. Square wall frame. Measure the wall diagonally (corner to corner). Then measure the opposite corners. These measurements will be the same if the wall is square.

4. Install the first siding panel with the 'LAP' edge flush with the end of the wall. Siding will extend 3/4" below the bottom plate. Nail siding with 6d galv. nails, spaced 8" apart.

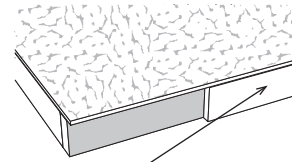

 Tip: use a 1x4 trim board as a gauge.

5. Install (2) two more siding panels. If necessary cut the last panel flush with the end of the frame.

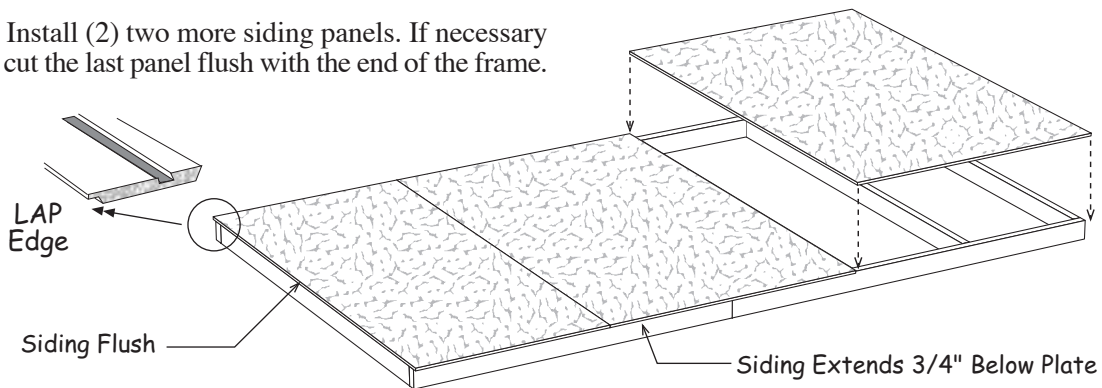

Step 2 Assemble 116-1/2" Side Wall Frames

1. Cut (2) two 2x4-10' boards to a length of 116-1/2". Position the boards together and indicate with 'X' marks where the wall studs will be located.
2. Mark a 'C' anywhere between first two stud marks. This is referenced in a later step.

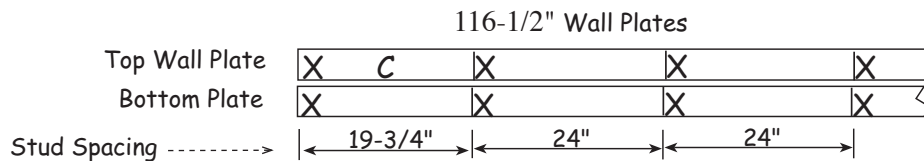

3. Install (6) six pre-cut wall studs between the top & bottom plates with (2) two 10d sinkers on each end.

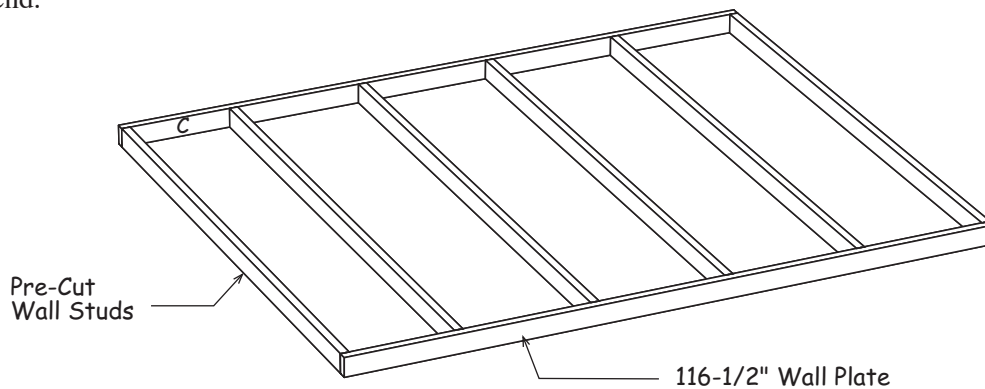

4. Repeat to assemble another 116-1/2" long wall frame. The siding will be applied after the walls are set on the floor.

Step 3 Assemble Door Header

1. Locate (2) two 2x8-8' boards. Cut these boards to a length of 76-1/4".
2. Assemble the door header using 2x8 boards and (2) two 7-1/4" x 48" OSB filler included in our kit. Install (1) one 48" long filler flush with end of 2x8. Cut to fit second OSB filler. Nail together with (12) twelve 10d sinkers spaced evenly on each side.

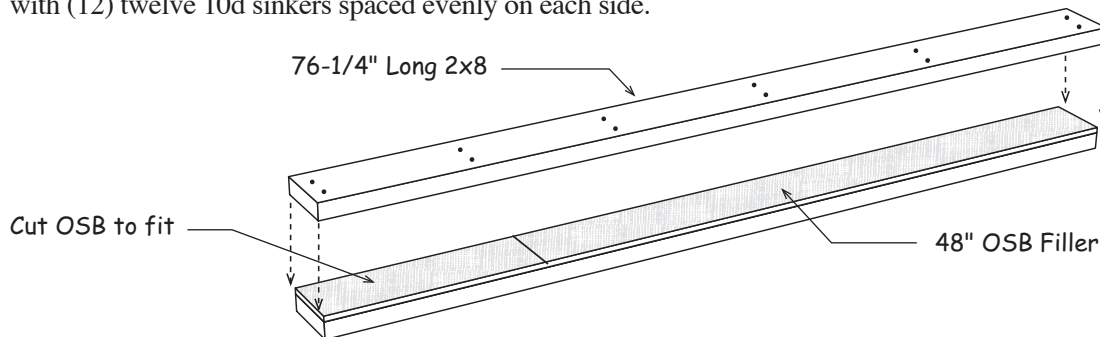

Step 4 Assemble 68-1/2' Side Wall Frames

1. Cut (2) two 2x4-8' to a length of 68-1/2". Position the boards together and indicate with 'X' marks where the wall studs will be located.
2. Mark a 'C' anywhere between first two stud marks. This is referenced in a later step.

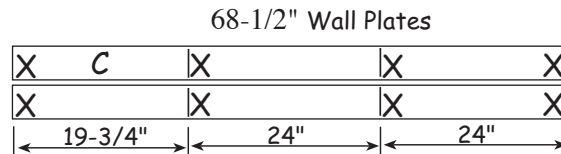

3. Install (4) four pre-cut wall studs between the top & bottom plates with 10d sinkers.

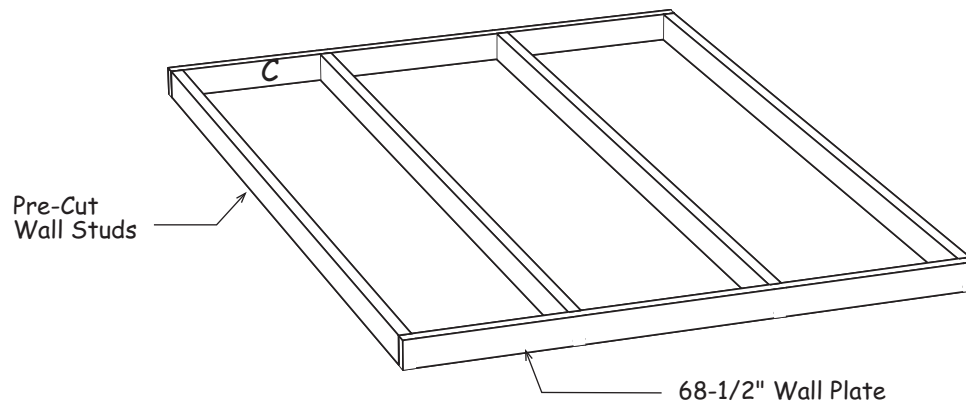

4. Repeat to assemble another 68-1/2" long wall frame. The siding will be applied after the walls are set on the floor.

Step 5 Assemble 96" Side Wall with Door

 **Refer to door manufacturers specifications for rough opening size. Adjust measurements accordingly.**

1. Position (2) two 96" long boards together and indicate with 'X' marks where the wall studs will be located.

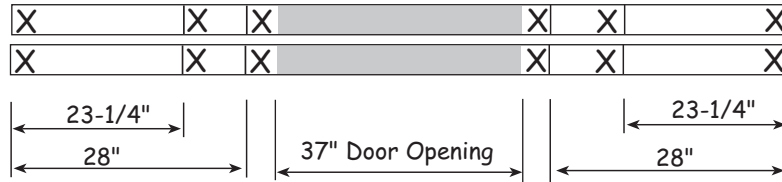

2. Install (6) six pre-cut wall studs between the wall plates.
3. Refer to the door manufacturers specifications for correct rough opening size. Cut (2) two pre-cut wall studs to correct length (remember to account for 2x4 bottom plate) and install as header supports on each side of the door opening, *see detail below*. Nail to studs with 10d sinkers.

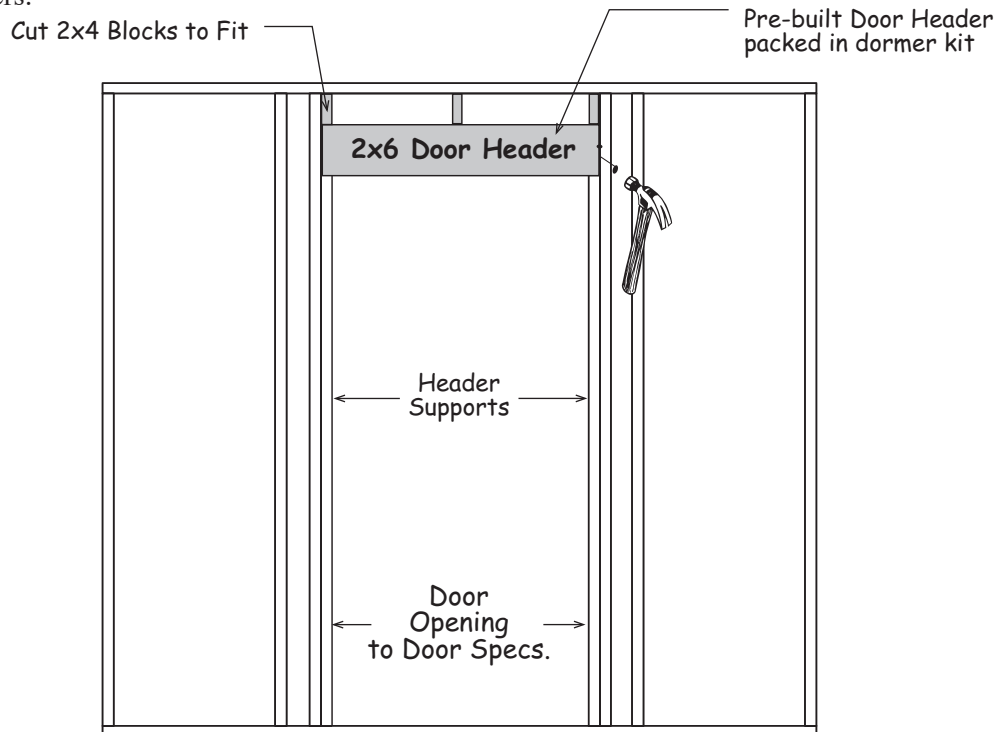

4. Install a 2x6x37" pre-built door header on the 2x4 header supports. The door header is *packed in the dormer kit*. Nail to studs with 10d sinkers.
5. Measure space between header and top plate. Cut (3) three 2x4s to this length and install above the door header as shown. Nail through top plate and toenail to header with 10d sinkers.

Step 6 Assemble Front Wall Frame

1. Cut (2) two 2x4-12' boards to a length of 144" for wall plates. Position the boards together and indicate with 'X' Marks where the wall studs will be located.

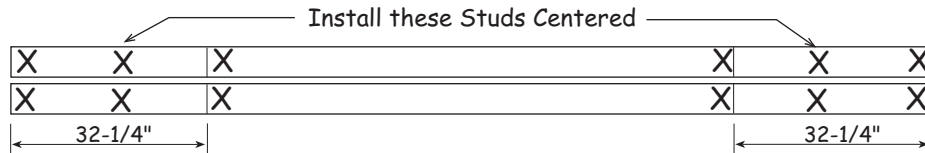

2. Install (6) six pre-cut wall studs between the wall plates where shown.

3. Cut (2) two pre-cut studs to a length of 75-1/2" and install as header supports. Nail to studs with 10d sinkers.

4. Install the door header on the 2x4 header supports. Nail to the stud with 10d sinkers.

5. Measure space between header and top plate. Cut from a pre-cut stud (4) four pieces to this length. Evenly space pieces and nail through top plate and toenail to header. Use 10d sinkers.

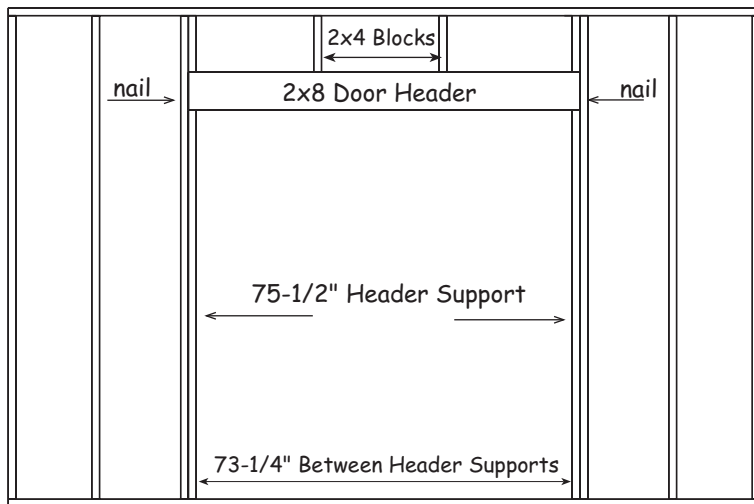

6. Place a full width siding panel with the 'LAP' edge flush with left side of wall frame. Siding should extend 3/4" below bottom plate. Before nailing siding, cut the siding flush with the side of the door opening and 3/4" below the door header.
7. Install a 20"x48" siding panel above the door opening. This siding must extend 3/4" below the door header. Top of siding might not be even with left or right siding.
8. Install a full width siding panel on the right side of the wall panel. Cut siding as previously instructed.

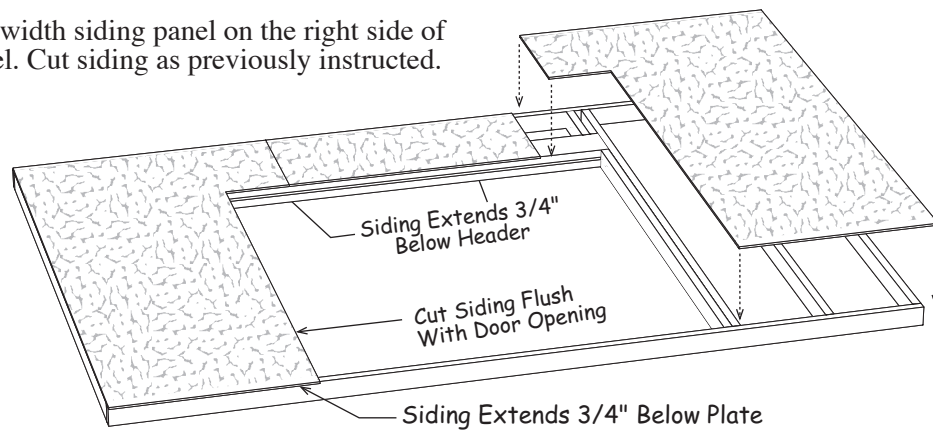

Step 7A Set Walls

1. Erect back wall and 10' side wall frames. **IMPORTANT:** Install the side wall frames with the 'C' marks oriented against the back wall panel and front wall corner. Secure walls together at the corner. Use (4) four 10d sinkers corner. Brace walls with pre-cut wall studs to hold walls secure and plumb.
2. Starting at right corner install a full width siding panel with the 'LAP' edge flush with the siding on back wall. Siding should extend $\frac{3}{4}$ " below bottom plate. Nail siding to back wall and all 2x4s using 6d galv. nails spaced 8" apart.

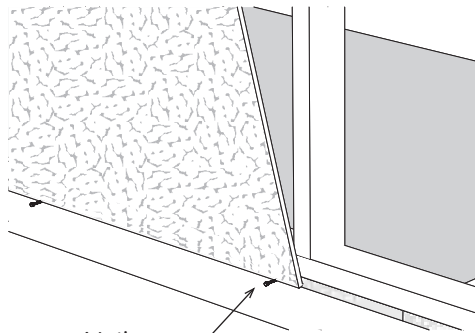

Tip: If you are erecting building on a wood floor insert nails between the $\frac{3}{4}$ " floor sheathing and the 2x4 floor frame. Rest the siding on the nails while nailing to frame.

3. Install (4) four more siding panels. Last panel will extend approximately 3-1/2" past wall frame to receive the side wall panel with the door opening.

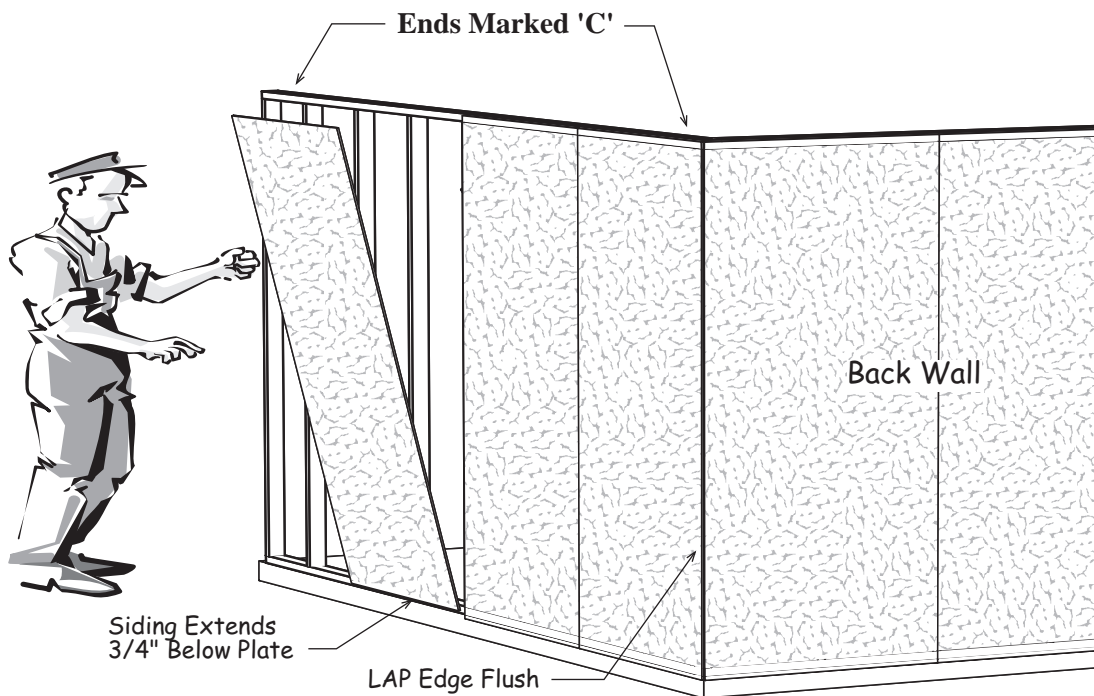

Step 7B Set Walls continued

- Erect the front door wall panel and the (3) three side wall frames. **IMPORTANT:** Install the 68-1/2" long side wall frames with the 'C' marks oriented against the back and front wall panels. Secure walls together at the corners. Use (4) four 10d sinkers per corner. Brace walls with pre-cut wall studs to hold walls secure and plumb.
- Starting at left corner install a full width siding panel with the 'LAP' edge flush with the siding on the back wall. Siding should extend 3/4" below bottom plate. Nail siding to front wall and all 2x4s using 6d galv. nails spaced 8" apart.
- Install a second full width siding panel.
- Before installing the next siding panel cut the siding flush with sides and top of door opening.
- Install the remaining siding panels.
- Locate where you want the windows, *packed in the dormer carton*, and cut openings in siding. Window installation instructions are in the window box.
- Cut and remove bottom 2x4 from door openings.
- Nail walls to floor through bottom plate. Space 10d sinkers or, if erecting on a concrete slab, concrete anchors (not included) spaced 24" apart.

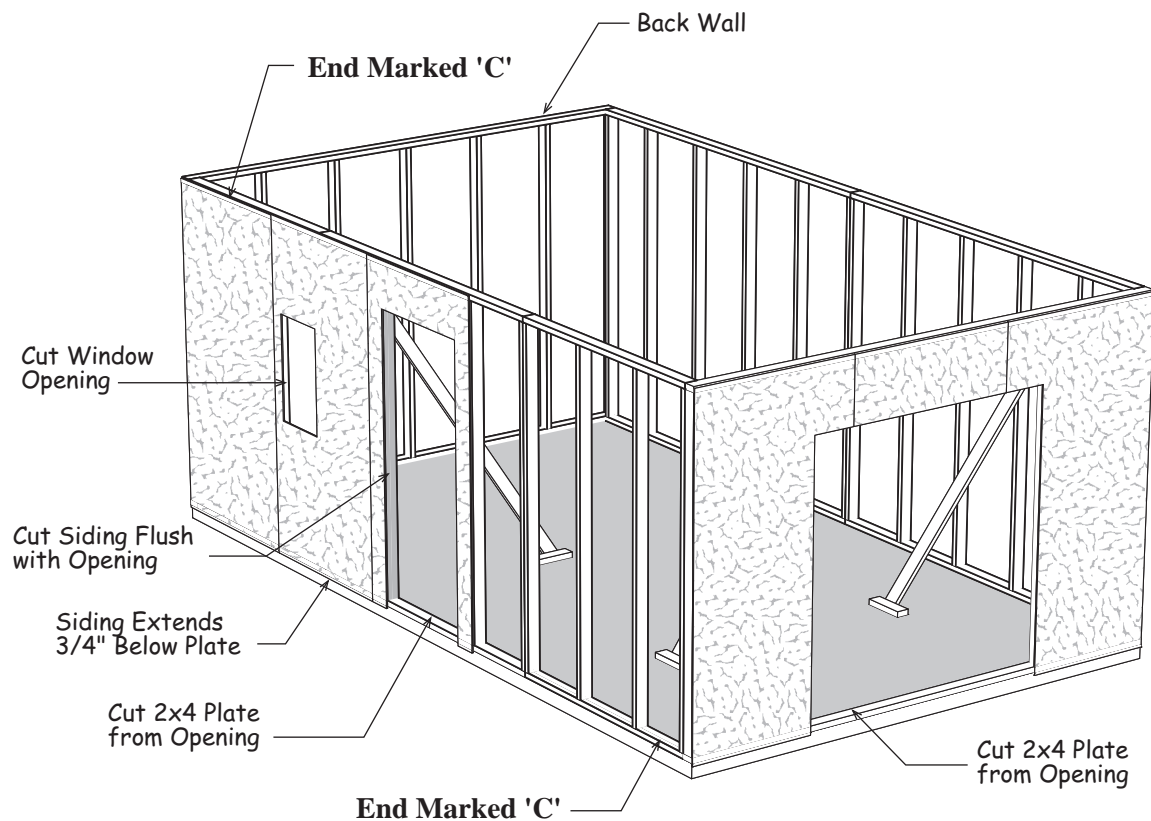

Step 8 Install 2x4 Tie Plates

1. Install a 2x4-8' on the side wall without door, flush with the 2x4 on the back wall. Install a 2x4-12' flush with the 2x4 on the front wall. Cut length to fit. Use 10d sinkers to secure the tie plates to front and back walls and along length.
2. Repeat to install 2x4s on the side wall with door.
3. Cut (2) two 12' long 2x4s to fit between side wall tie plates and install on front and back walls.

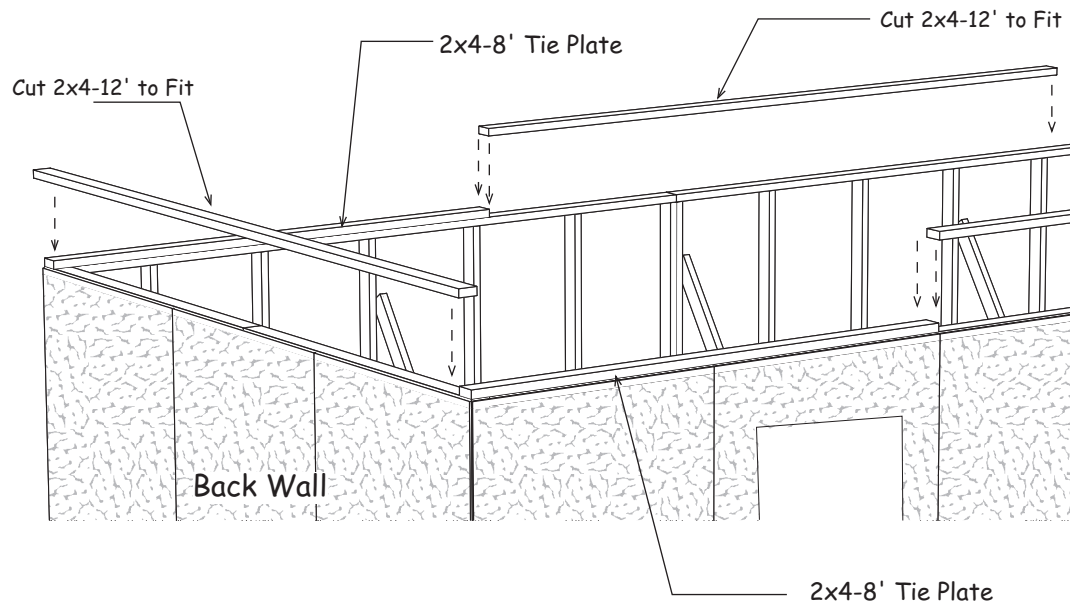

Step 9 Install Metal 2x4 Joist Hangers

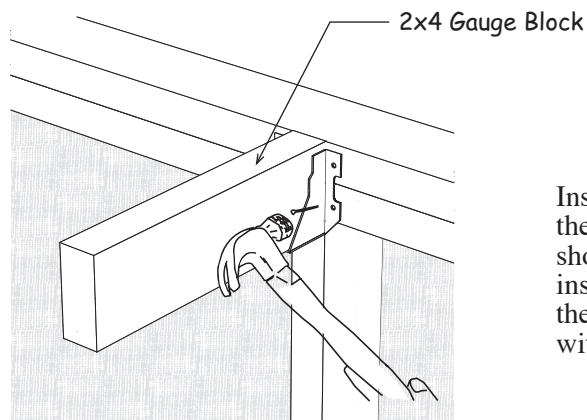

Install (18) eighteen 2x4 joist hangers aligned with the wall studs on the front and back walls. Use a short 2x4 block as a gauge to ensure the 2x4s, installed in next step, will be flush with the top of the 2x4 tie plate when installed. Secure the hanger with 1-1/2" hanger nails.

Step 10 Install Loft Floor

Important: Before securing the 2x4 floor joists make sure the side walls are plumb. The building width should be 12'-0" measuring from the outside of the 2x4 tie plates.

Cut (9) nine 2x4-12' boards to a length of 137" and install in the metal hangers. Use 1-1/2" hanger nails.

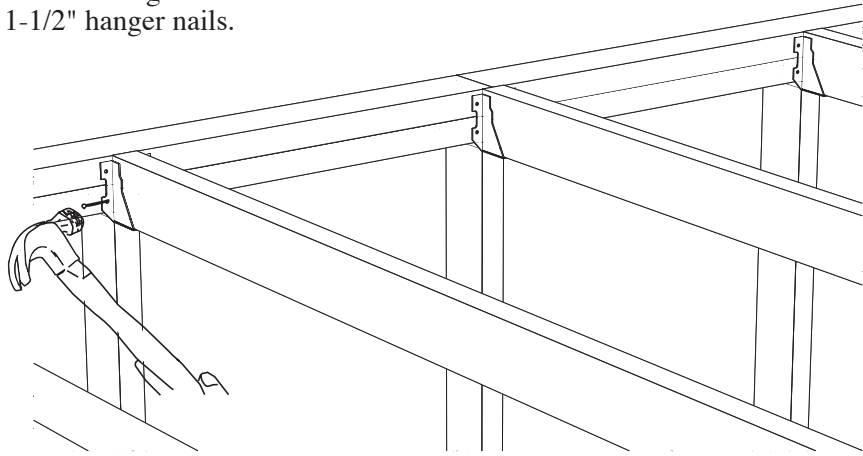

Step 11 Install Loft Floor Sheathing



Before installing floor sheathing consider where to locate the 2' x 4' access opening. The detail below shows one possibility. Regardless of desired layout it is important to install sheathing staggered when possible.

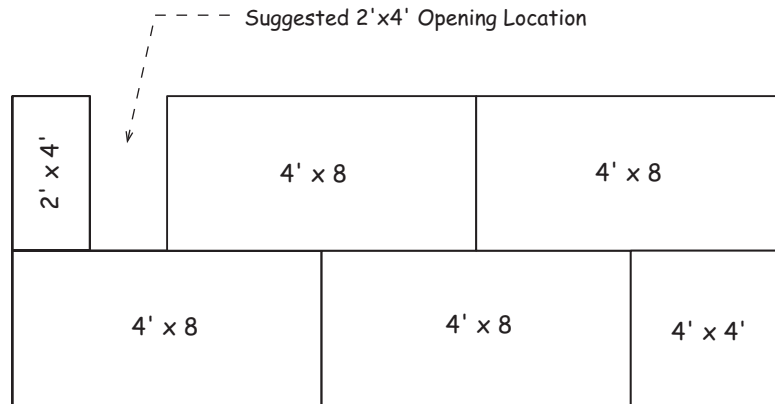

1. Locate (4) four 3-1/2" x 24" OSB fillers. Install at front and back corners on top of 2x4 tie plates. Use (4) four 6d common nails each. Insure the space between fillers is 96".
2. Install loft flooring between OSB fillers. Edge of sheathing should be flush with front and back wall tie plates. Refer to the suggested layout on previous page. Install flooring using 6d common nails spaced 12" apart.

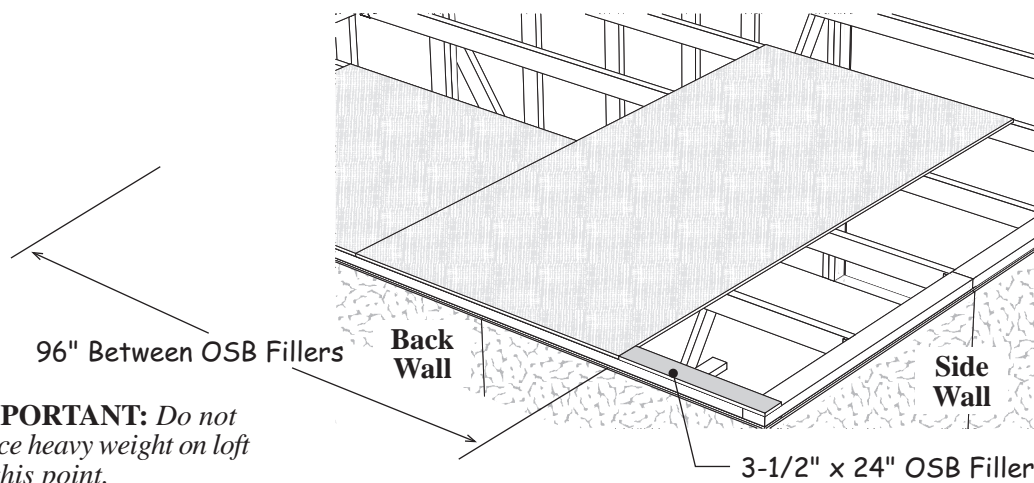

IMPORTANT: Do not place heavy weight on loft at this point.

3-1/2" x 24" OSB Filler

Step 12 Install Corner Trim

IMPORTANT: Trim Must Be Installed Before Installing Roof Gables!

1. Locate (3) three 2" x 48-3/4" Siding filler strips. Nail these on top of the siding on the back wall. Use a few 6d galv. nails. More nails will be used on trim.
2. Locate (4) four 27" long and (4) four 72" long 1x3 trim boards. Install 72" long boards on the back wall at corners flush with side wall siding and top of OSB filler. Nail with (2) two 6d galv. nails 3/8" from top and bottom of board. Then nail staggered along board 12" apart. *See diagram below.*
3. Install 27" long boards under 72" long boards. Leave a gap of 3/16" to allow for sealant to fill gap. If necessary cut trim to be flush with bottom of siding. Fill gap with sealant.

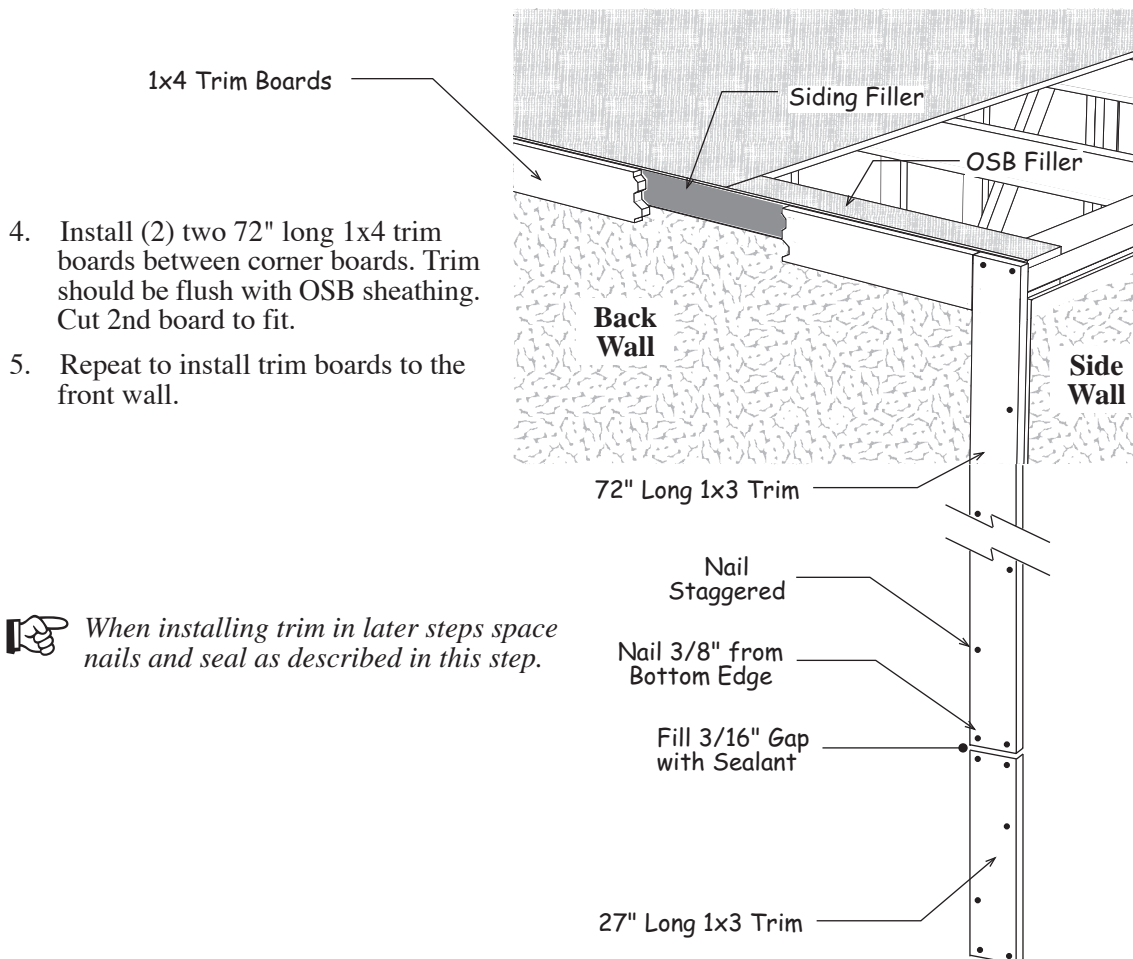

Step 13A Assemble Gables

1. Gather pre-built gable end frames, (1) one left and (1) right, (1) one 49-1/2" long 2x4 and (2) two 32-1/2" long 2x4s with angled ends.
2. Position these components together as shown below. When aligned correctly the bottom 2x4s will be straight and measure 12'-0" from end to end. *Pre-built gable ends highlighted in gray.*
3. Temporarily tack 1x4 blocks to loft flooring around the frame members. These blocks will be 8"-12" long and may have angled ends. Make sure (2) two of these blocks are positioned inside each pre-built gable end frame as shown. Position the rest of the blocks appropriately spaced to hold 2x4s in place. These will insure that all trusses and gables are built exactly the same. **DO NOT** nail blocks to gable.
4. Secure the bottom 2x4 to the gable stud using (2) two 2-1/2" screws.
5. Locate (2) two 5-3/4"x14" OSB gussets. Attach these to top of each gable stud to secure frame to 32-1/2" 2x4s. Use 6d common nails. See Detail 'A'.

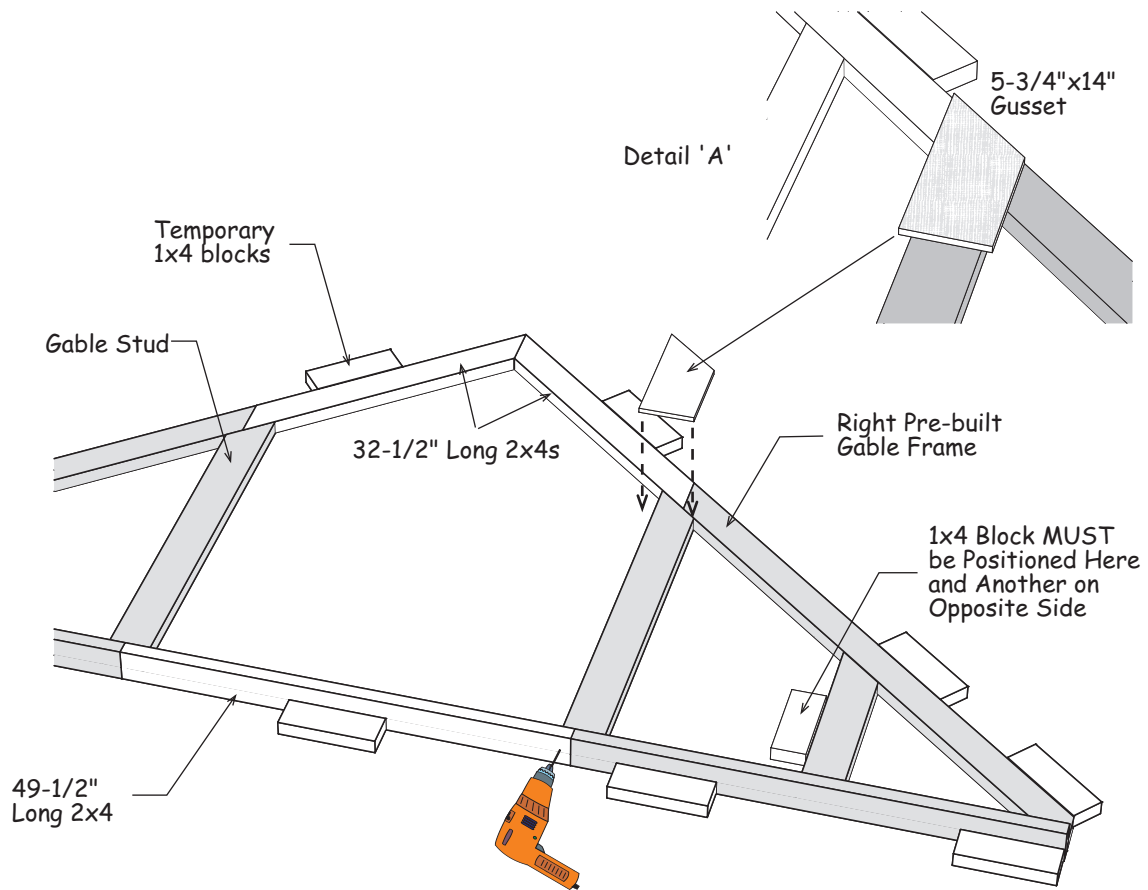

Step 13B Assemble Gables Continued

5. Locate (2) two 50-3/4" long 2x4s. Install these equally spaced from center of the gable. Secure the bottom 2x4 to the gable studs using (2) two 2-1/2" screws each.
6. Install a wood gusset at peak. Nail using (14) fourteen 6d common nails.
7. Locate (2) two 5-1/2"x27-3/4" gussets. Attach these to top of each gable stud to secure to the 32-1/2" 2x4s. Use 6d common nails.

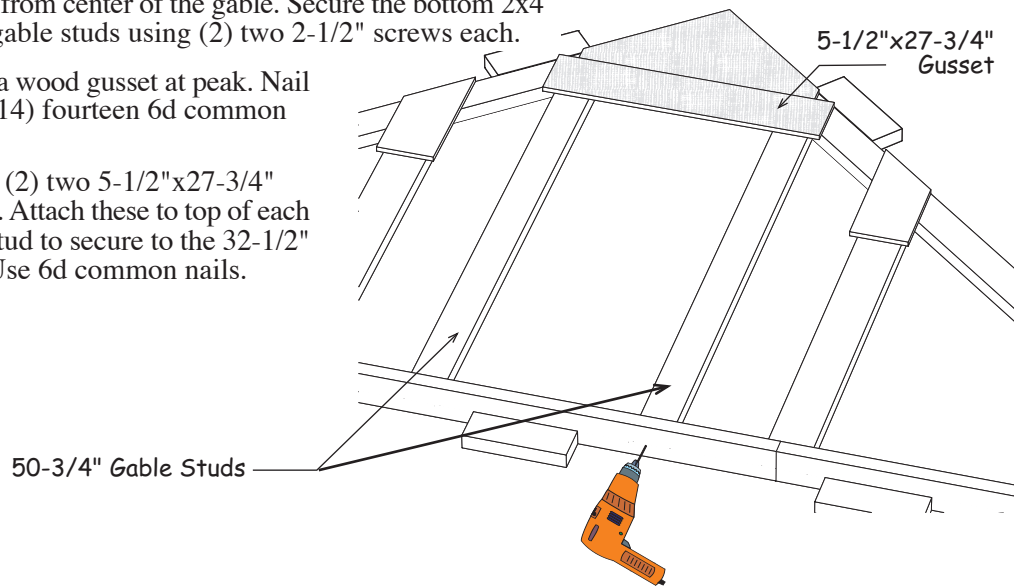

Step 14A Install Front Gable Siding

 *Gable siding is factory cut to be installed either working from left to right or right to left. Regardless of the direction always begin with the 'LAP' Edge flush with end of the gable.*

1. Carefully turn the gable frame over. Temporarily place 2x4s under the gable frame to keep the frame level while installing the gable siding.
2. Locate pre-cut gable siding. Install siding with 'LAP' edge flush with end of gable. Install with siding extending 3/4" below the bottom 2x4 plate. Use 6d galv. nails spaced 8" apart.

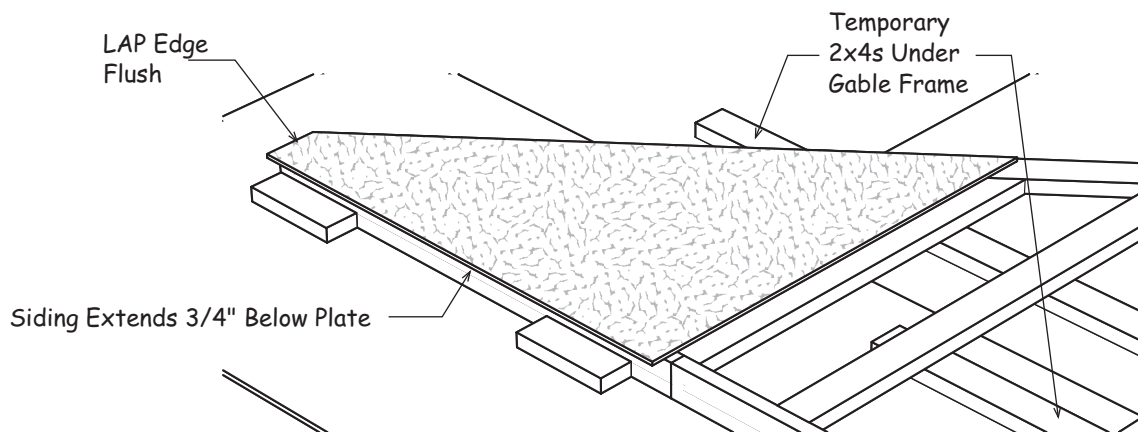

Step 14B Install Gable Siding continued

 **This model has 3 sunburst windows included for dormers and one gable end. Cut out window opening in one gable only unless an additional sunburst window was purchased.**

3. Install center siding panel. Locate sunburst window, *packed in dormer carton*, and cut out siding according to window instructions. It is advisable to install the window after gable is set.

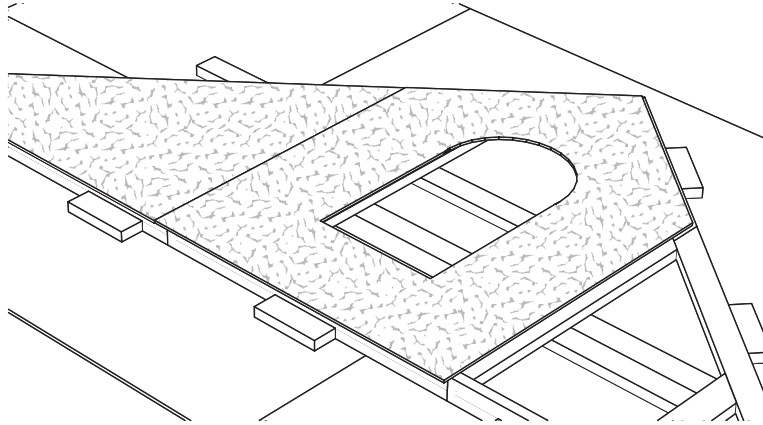

4. Install last siding panel.

Step 15 Install Gable Overhang

1. Locate (2) two 77-3/8" long 2x4 rafters on gable. Install 2x4s flush with the top of gable frame. Use 10d sinkers.
2. Locate (2) two 30-3/4" long 2x4 rafters and install to finish. 2x4s will extend beyond end of gable.

Do not remove the temporary 1x4 blocks until the roof trusses and back gable are assembled.

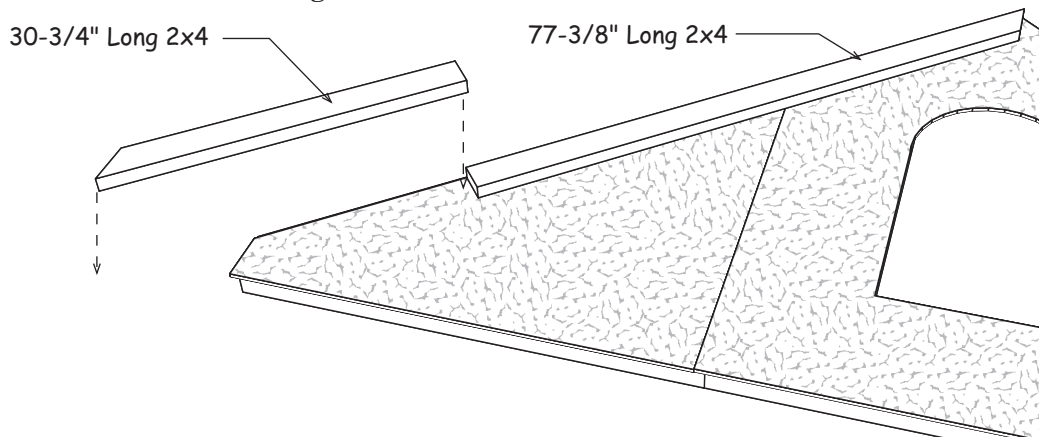

Step 16 Set Front Gable

 **Important: Temporarily brace the gables with 2x4s to secure gables until the roof sheathing is installed!**

1. Install gable on the front wall. Secure bottom of gable to loft floor and OSB fillers using 10d sinkers.
2. Nail the bottom edge of the siding into the 1x4 trim. Use 6d galv. nails.

Bottom edge of gable siding extends over 1x4 trim

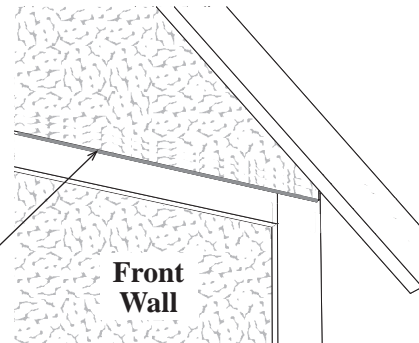

Step 17 Assemble Rear Gable

Repeat Steps 13 through 16 to assemble and set rear gable.

Step 18 Assemble Roof Trusses

1. Insert left and right pre-built truss ends into the blocks that held the gable frames in place. Insure span is 12'-0" between truss ends as indicated in drawing below.
2. Butt (2) two 77-3/8" long 2x4s against the truss ends. Remove the 1x4 blocks that secured the bottom gable plate and reposition to keep rafters aligned. Locate a 18-1/2" long 2x4 ridge block with angled ends and install at peak. Secure rafters and ridge block at peak with a wood gusset. Install with (14) fourteen 6d common nail.
3. Install gussets on truss ends. See Detail A. Install with (20) twenty 6d common nails.
4. Carefully flip truss over and install another gusset at the peak.
5. Set truss aside. Repeat steps to build (8) eight more trusses.
6. Remove temporary 1x4 blocks.

 **Tip: Place a gusset under rafters to help level.**

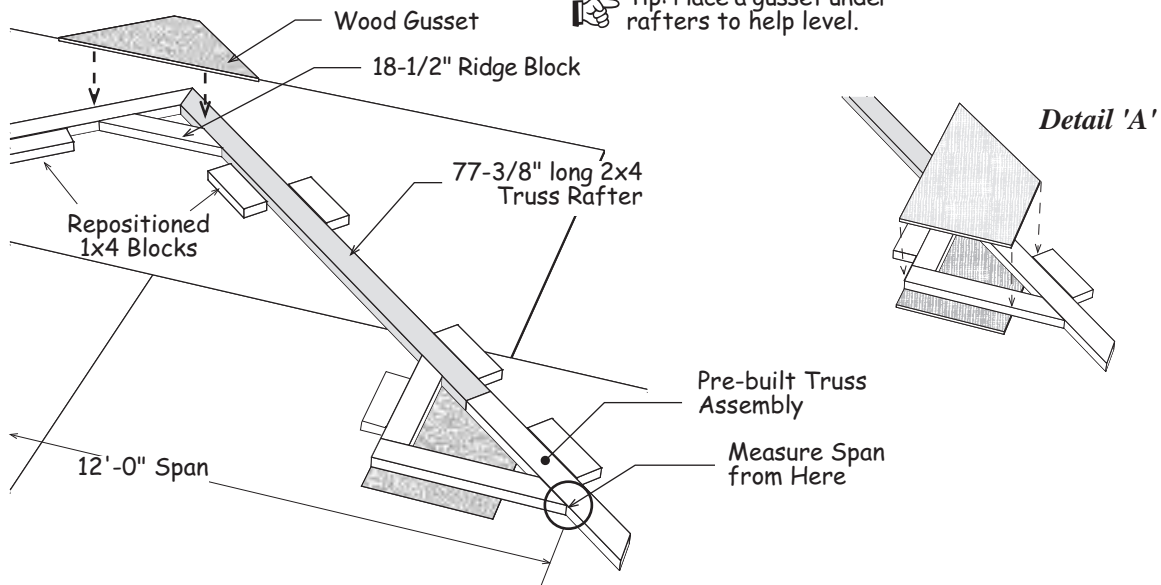

Step 19A Set Trusses

1. Starting at back gable set a truss by sliding ends over 2x4 floor joist. Truss ends should set flat atop floor joist. Secure with (10) ten 6d common nails on both sides.
2. Continue standing trusses to front of building. Make sure trusses and gables are plumb. If necessary span a 2x4 across tops and tack to keep plumb until roof sheathing is installed.

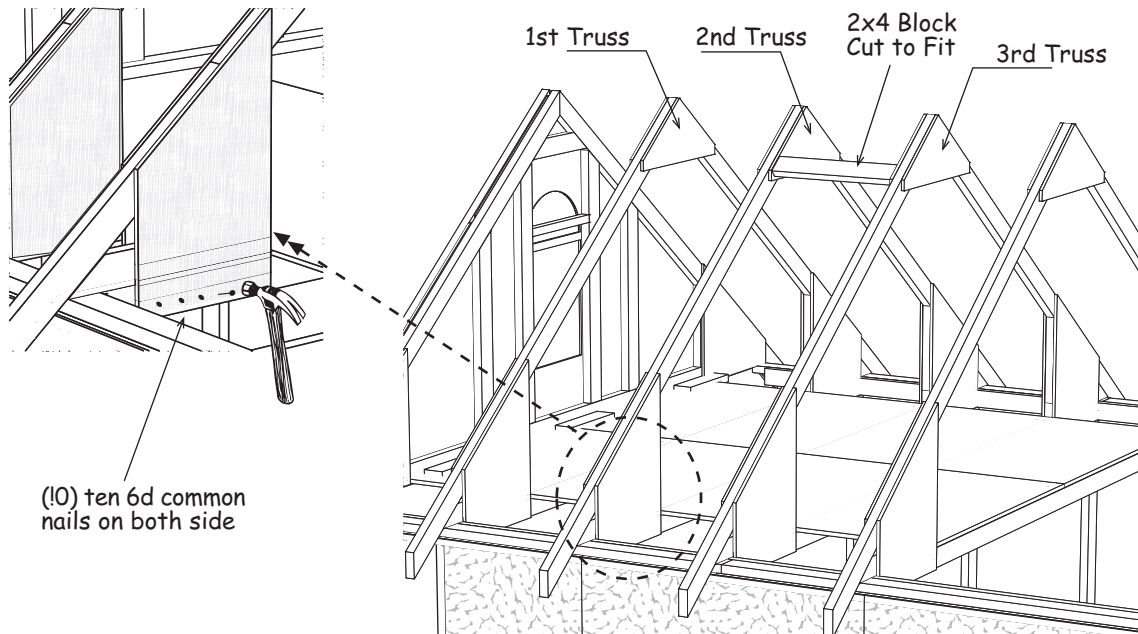

3. Locate the 2x4 that was cut and removed from the door opening on the 12' end wall. Measure and cut to length a 2x4 to fit between the gussets on the 2nd and 3rd trusses.
4. Determine the side of roof you will be installing dormers on. Install cut 2x4 between trusses as shown, see above drawing. Use (2) two 4" wood screws on each end. Screws are packed in the dormer kit.

Install 2x4 at end of gusset

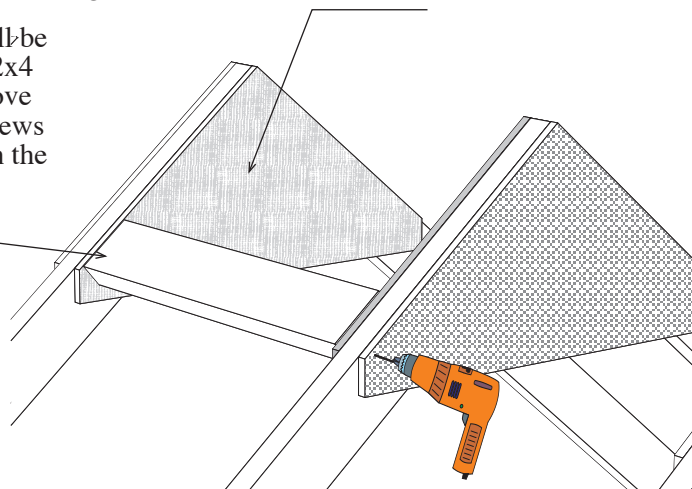

Step 19B Set Trusses continued

4. Cut to length and install another 2x4 between the truss gussets where shown below.

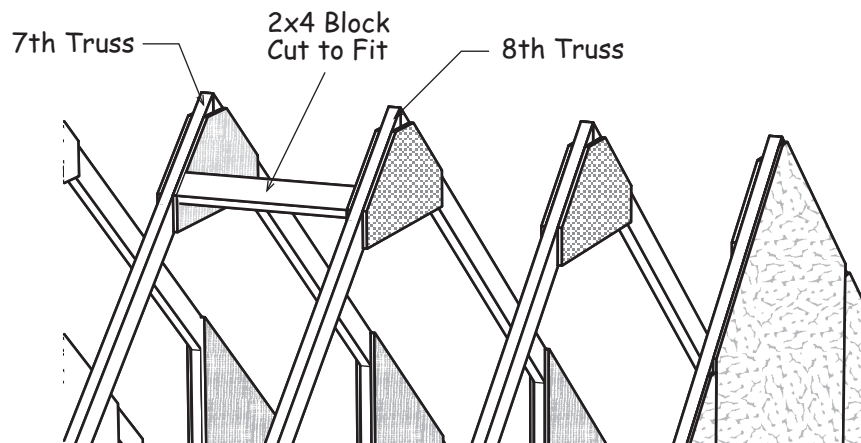

Step 20 Install Side Wall Trim

 *It's easier to install the soffit if the corner and side wall trim are installed first. This enables the soffit to rest on the trim where it meets the building. See lower detail.*

1. Locate a 3/8" x 3" x 8" siding gauge block packed in the hardware bag. Place this gauge block under the 2x4 overhang and butt a 72" long 1x4 trim board against it. Install trim flush with the corner trim on the back of the building. Use 6d galv. nails.
2. Install a 27" long 1x4 under 72" board.
3. Repeat to install corner trim at the other three corners.
4. Install (3) three 72" long 1x3 trim board along the top of the side wall. Use the gauge block to properly set trim. Cut a 4' long 1x3 board to finish.
5. Repeat on opposite side wall.

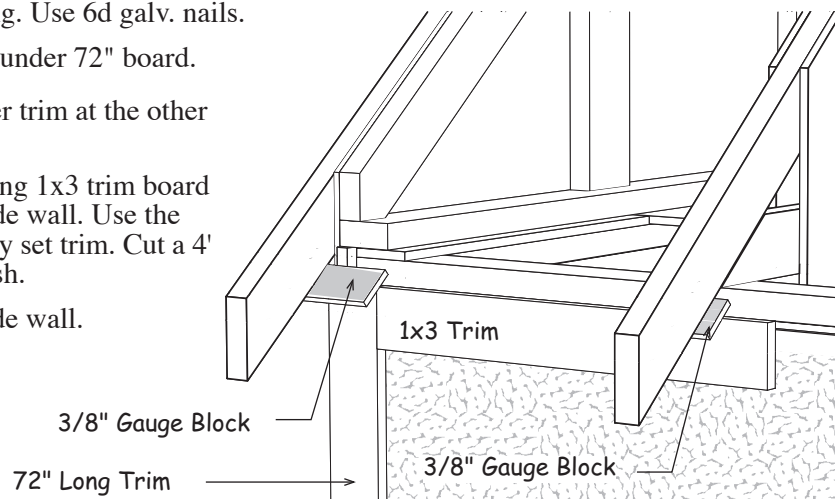

Step 21 Install Soffit

1. Locate a 9-3/4" x 48" soffit panel. Measure from center of first truss to face of the 2x4 installed on the front gable. Mark this length from tongue edge side cut off 'LAP' edge end of panel.
2. Nail the soffit panel to the end of the 2x4s. See **Detail 'C'** below.
3. Install (5) five 9-3/4" x 48" soffit panels along the side of the building cutting the last soffit panel flush with the 2x4 on the rear gable.
4. Repeat to install soffit panels on the opposite side wall.

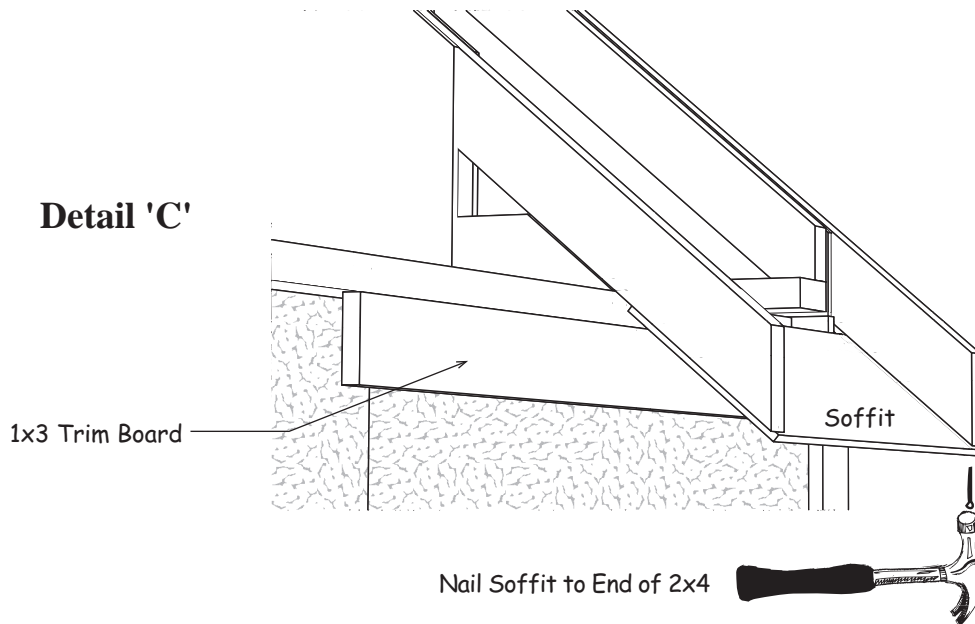
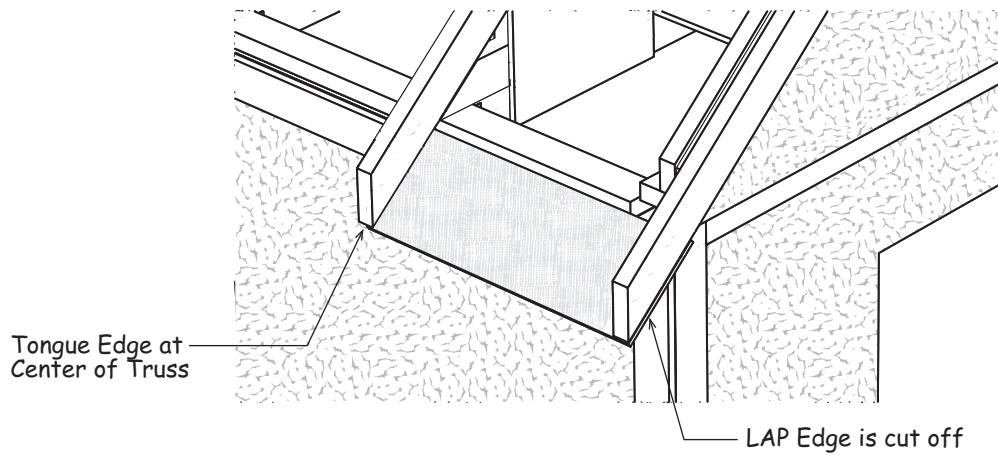

Step 22 Install 1x6 Fascia on Side Walls

1. Starting at the back gable, install a 75" long 1x6 trim board flush with the face of the 2x4. Install the 1x6 board so the top of the board is aligned with the top of the trusses. The roof sheathing, *installed later*, should rest on the fascia. Use a straight edge as shown below. Use 6d galv. nails.
2. Install (2) two 1x6-6' trim boards next.
3. Cut a 48" long 1x6 trim board flush with the outside 2x4 on the front gable.
4. Repeat on opposite side wall.

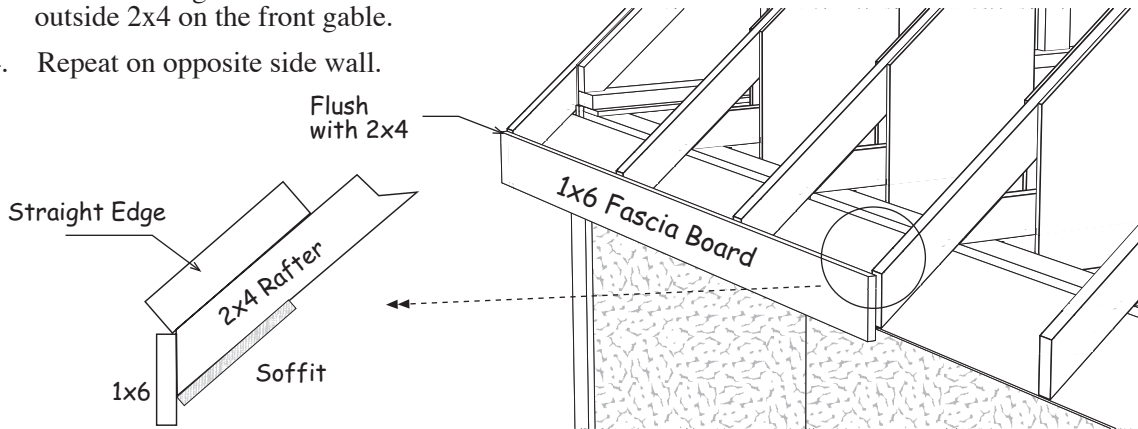

Step 23A Install Roof Sheathing

1. Locate (2) 48"x 96" sheets of OSB. Cut from these (2) two 48"x 51" sheets. From drops cut (2) two 48"x 27" sheets.
2. Locate (2) 48"x96" sheets of OSB. Cut these in half to make (4) four 48"x48" sheets.
3. Before installing roof sheathing make sure the trusses and gables are plumb. Starting at the rear gable install sheathing per the layout on the next page. Secure sheathing with 6d common nails. Space nails 12" apart.

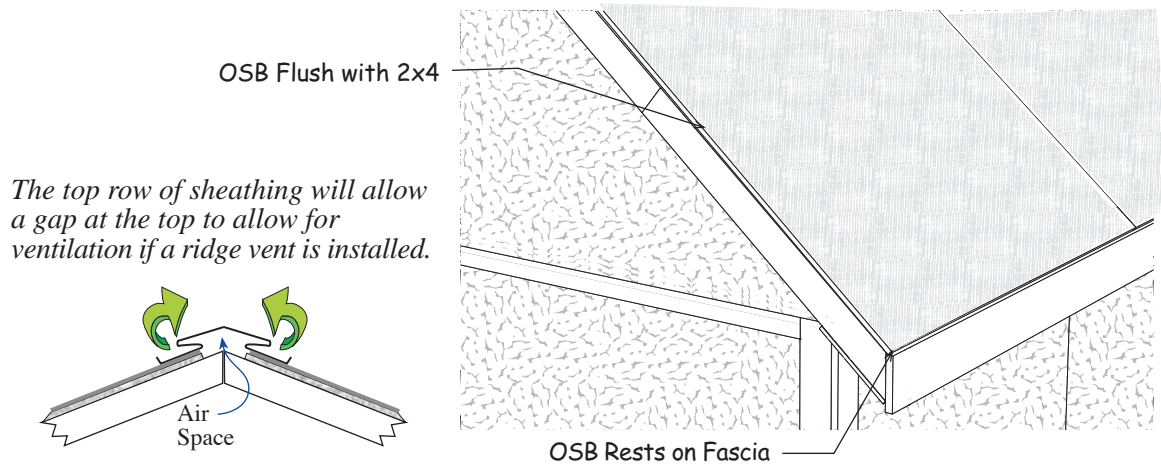

Step 23B Install Roof Sheathing continued

4. When installing sheets at front gable cut flush with the 2x4s on the gable.
5. Insert (2) two ply-clips into the roof sheathing between each truss at the top row, see drawing below.
6. Cut a 59-1/4" piece on top row so to be flush with front gable 2x4s.
7. Determine location for dormers and follow instructions in dormer kit.



Insert (2) two ply-clips into the roof sheathing between each truss at the top row

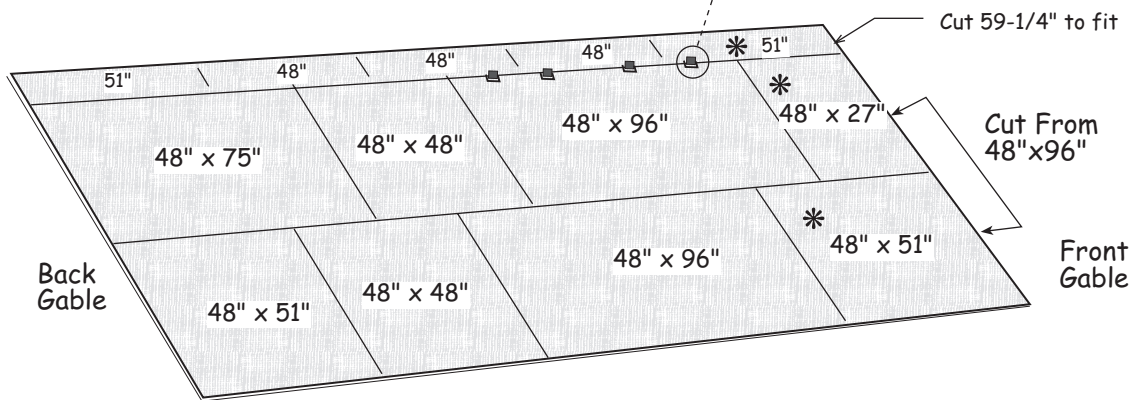
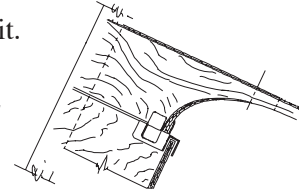

* Cut sheets to finish at front gable

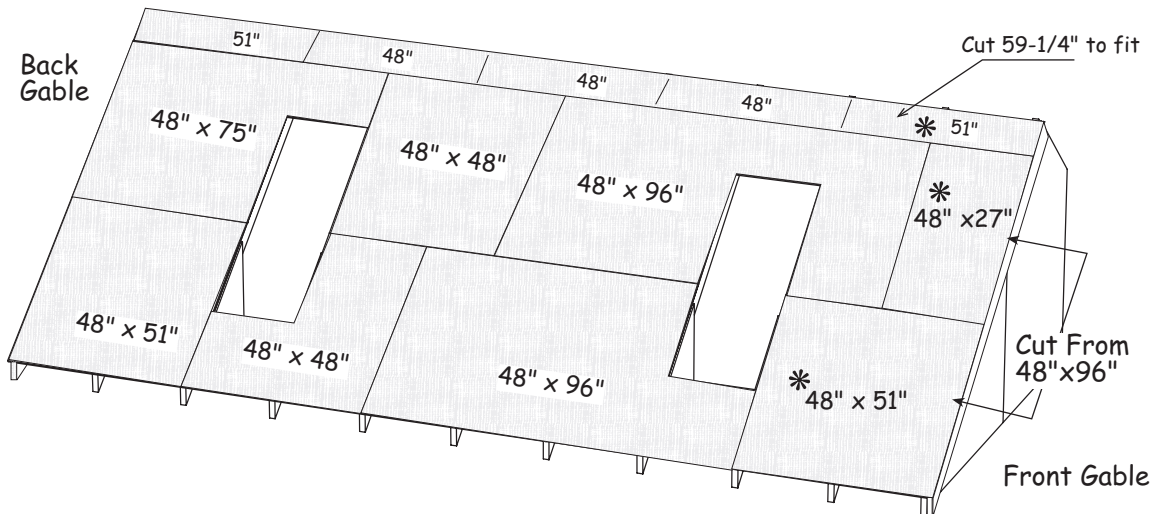

Refer to dormer kit instructions for installing the roof dormers.

Step 24 Install Gable Trim

1. On front gable install (2) two 38-3/4" long 1x6 trim boards with angle cut on one end over the 2x4 boards at the peak. Trim should be flush with the top of the OSB roof sheathing. Use 6d galv. nails.
2. Finish with (2) two 72" long 1x6 trim boards.
3. Repeat to install gable trim on the rear gable.

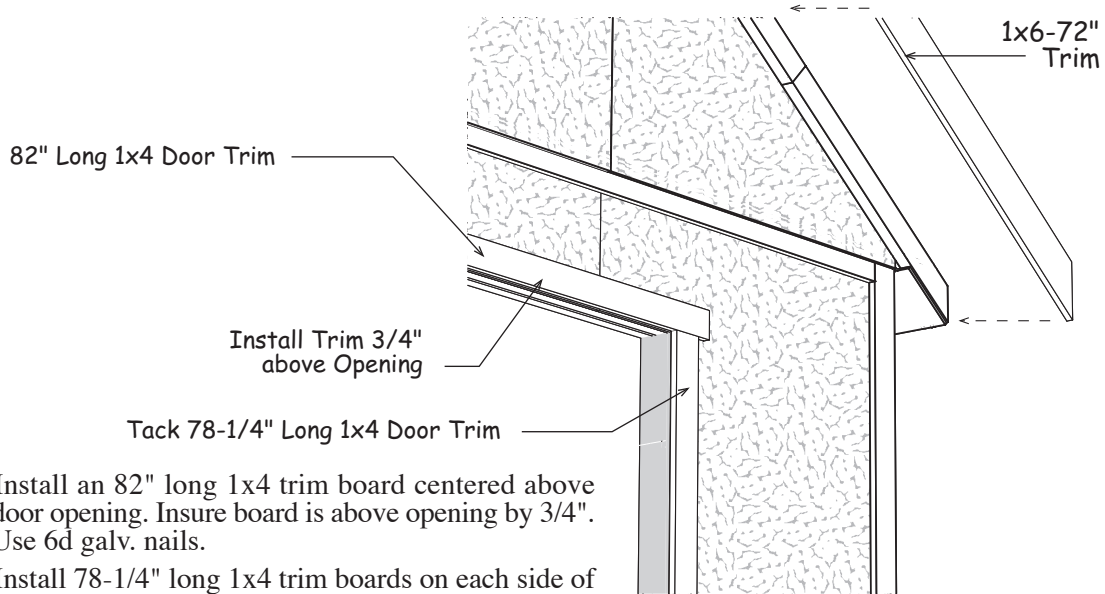

4. Install an 82" long 1x4 trim board centered above door opening. Insure board is above opening by 3/4". Use 6d galv. nails.
5. Install 78-1/4" long 1x4 trim boards on each side of the door opening and under horizontal trim. Tack nail these trim boards for now, you may want to move the trim when you want to installed the doors.

Step 25 Install Door Stop on Left Door

Select a door without a pre-drilled hole for handle and lay trim side down. Install a 4-1/4" x 75-1/4" long siding panel as a door stop to the right side of door. *See detail below.* The door stop should extend 3/4" beyond the side frame of the door and be flush with top of 2x4. Install with 1-1/2" exterior screws spaced 12" apart.

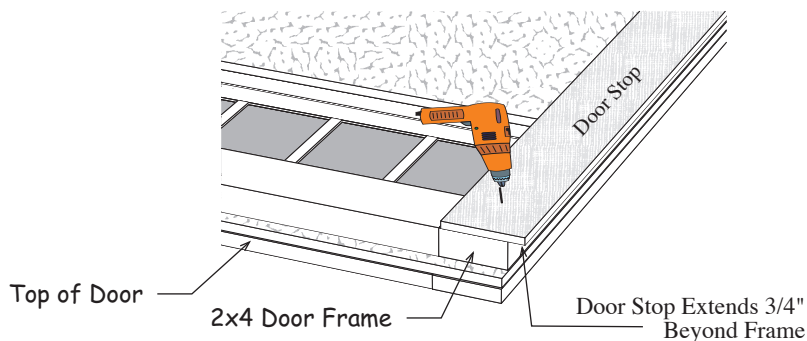

Step 26 Install Doors



If your door opening is out of square, the space around the doors will not be even. You can remove and re-position the side trim to make allowances for this. The side trim does not have to be flush with the frame of the door opening. You can move the trim in or out to make the door spacing equal.

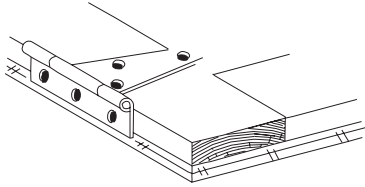

1. Install (3) three 5" hinges to sides of the doors. To position the hinge properly, hold the rectangular plate against the frame. Use 1-1/4" black screws.
2. Before fastening the hinges to the trim, temporarily prop the doors in the opening. Leave a space at the top and between the doors and the side trim to allow room for the doors to expand due to humidity.
3. Determine position of hinges and install to side trim with 2" screws.
4. Install the window using the short white screws.
5. Install door handle using 2" black screws into the pre-drilled hole on right side door. When the handle is turned the inside latch will hold doors closed. Tighten set screw to finish.

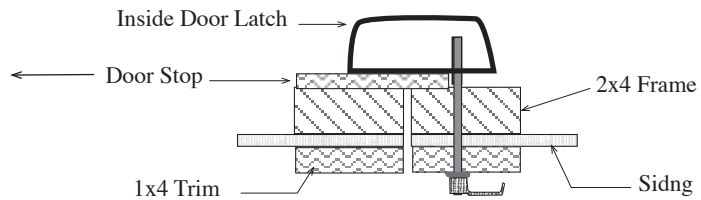
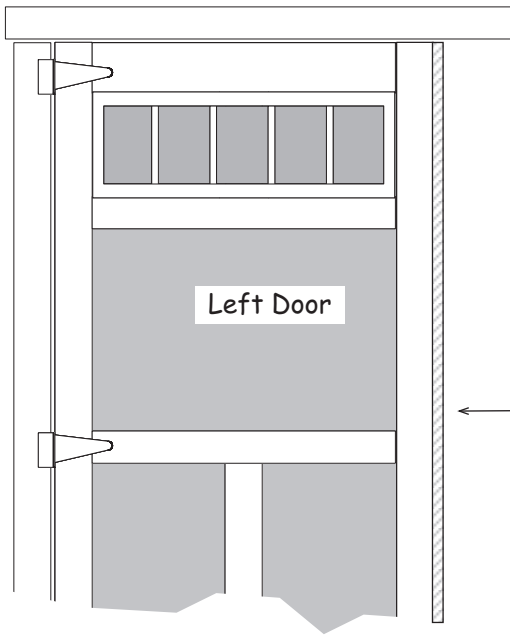

6. Install a barrel bolt using 3/4" pan head screws on the inside lower back of the left door to secure this door in place when closed. You will need to drill a hole for the round shaft to drop into.
7. Install another barrel bolt at the top of the door.

Barrel Bolt on the back of left door

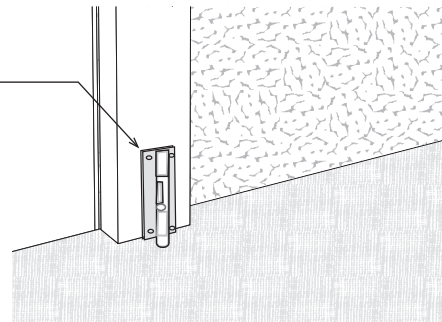

Install Roofing — Not Supplied in Kit

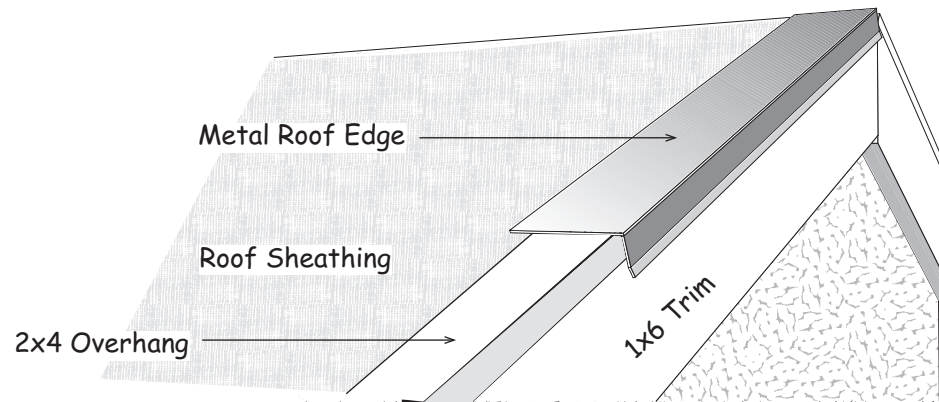

1. Install metal roof edging along the end walls and the front edge of the roof sheathing.
2. Install felt paper and shingles according to manufacture's instructions.

Optional Roof Covering

| | | |
|----|------|----------------------|
| 14 | bdl. | Roof Shingles |
| 10 | pcs. | Roof 'drip' Edge-10' |

| <i>Qty.</i> | <i>Material Shipped in 4' Extension Kit</i> | |
|-------------|---|---------------------|
| 4 | Truss Rafters | 2x4 77-3/8" |
| 2 | Trim Boards | 1x3 48" |
| 2 | Trim Boards | 1x6 48" |
| 2 | Ridge Block | 2x4 18-1/2" |
| 2 | Pre-built Truss Assemblies - lefthand | |
| 2 | Pre-built Truss Assemblies - righthand | |
| 2 | Primed Soffit Boards 3/8" x 9-3/4"x 48-3/4" | |
| 2 | OSB Sheathing | 7/16" x 9-3/4"x 48" |
| 4 | Wood Gussets | 15-3/4" x 27-1/2" |
| 4 | Joist Hangers | 2x4 |
| 1 | lb. 10d Sinkers | |
| 1 | lb. 6d Common Nails | |
| 1 | lb. 6d Galv. Nails | |

| <i>Qty.</i> | <i>Supplied by Local Supplier</i> | |
|-------------|-----------------------------------|--------------------|
| 46 pcs. | 2x4 | Pre-cut Wall Studs |
| 17 pcs. | 2x4 - 12' | Wall & Tie Plates |
| 8 pcs. | 2x4 - 8' | Wall & Tie Plates |
| 4 pcs. | 2x4 - 10' | Wall Plates |
| 2 pcs. | 2x8 - 8' | Door Header |
| 15 pcs. | Exterior Siding | 4x8 |
| 12 pcs. | OSB Sheathing | 4x8 |
| 1 pc. | 9-Lite Exterior Door | |
| 1 pc. | Lock Set | |

| <i>Qty.</i> | <i>Material Shipped in 36" Door Kit</i> | |
|-------------|---|----------------------------|
| 2 | ea. | 36" x 76" Pre-built Doors |
| 2 | ea. | 12" x 31" Transom Windows |
| 2 | ea. | 1x4" x 78-1/4" Door Trim |
| 1 | ea. | 1x4" x 82" Door Trim |
| 1 | ea. | 4-1/4" x 75-1/2" Door Stop |
| 6 | ea. | 5" Door Hinges |
| 1 | ea. | Door Handle & Latch |
| 2 | ea. | 6" Barrel Bolt |
| 25 | ea. | 1-1/4" Hinge Screws |
| 27 | ea. | 2" Hinge Screws |
| 16 | ea. | 3/4" Pan Head Screws |
| 10 | ea. | 1-1/2" Exterior Screws |
| 32 | ea. | White Window Screws |

| Qty. | <i>Material Packaged on Pallet</i> | | |
|------|---|-----|---------|
| 20 | Truss Rafters | 2x4 | 77-3/8" |
| | 2 Not used in this model | | |
| 7 | Ridge Block | 2x4 | 18-1/2" |
| 6 | Gable Overhang | 2x4 | 30-3/4" |
| | 2 Not used in this model | | |
| 4 | Gable Rafters | 2x4 | 32-3/8" |
| 2 | Gable Plates | 2x4 | 49-1/2" |
| 4 | Gable Studs | 2x4 | 50-3/4" |
| 10 | Trim | 1x3 | 72" |
| 4 | Trim | 1x3 | 27" |
| 8 | Trim | 1x4 | 72" |
| 4 | Trim | 1x4 | 27" |
| 2 | Trim | 1x6 | 75" |
| 4 | Trim | 1x6 | 72" |
| 4 | Trim w/Angle Cut | 1x6 | 72" |
| 4 | Trim w/Angle Cut | 1x6 | 38-3/4" |
| 2 | Pre-built Gable Frames - lefthand | | |
| 2 | Pre-built Gable Frames - righthand | | |
| 7 | Pre-built Truss Ends - lefthand | | |
| 7 | Pre-built Truss Ends - righthand | | |
| 2 | Pre-cut 46" High Gable Siding - tongue edge | | |
| 2 | Pre-cut 46" High Gable Siding - lap edge | | |
| 2 | Pre-cut 66" High Gable Siding - center | | |
| 2 | Pre-cut Siding 20" x 48-3/4" | | |
| | 1 Not used in this model | | |

| Qty. | <i>Material Packaged on Pallet</i> | | |
|------|------------------------------------|---------------------------------|--------------|
| 1 | 7/16" | 48" x 24" OSB Sheathing | |
| 2 | 7/16" | 48" x 51" OSB Sheathing | |
| 1 | 7/16" | 48" x 48" OSB Sheathing | |
| 2 | 7/16" | 48" x 75" OSB Sheathing | |
| 4 | 7/16" | 9-3/4" x 48" OSB Sheathing | |
| 2 | 7/16" | 9-3/4" x 51" OSB Sheathing | |
| 2 | 7/16" | 9-3/4" x 59-1/4" OSB Sheathing | |
| 4 | 7/16" | 3-1/2" x 24" OSB Sheathing | |
| 2 | 7/16" | 7-1/4" x 48" OSB Header Fillers | |
| 14 | 3/8" | Soffit Boards 9-3/4" x 48-3/4" | |
| | 4 Not used in this model | | |
| 6 | 3/8" | Filler Boards 2" x 48-3/4" | |
| 4 | lbs. | 10d | Sinkers |
| 5 | lbs. | 6d | Galv. Nails |
| 7 | lbs. | 6d | Common |
| 1 | lb. | 1-1/2" | Hanger Nails |
| 25 | 2-1/2" | Wood Screws | |
| 14 | 2x4 | Joist Hangers | |
| 50 | Plyclips for Roof Sheathing | | |
| 14 | Wood Gussets | 15-3/4" x 27-1/2" | |
| 16 | Wood Gussets | 24" x 11" | |
| 4 | Wood Gussets | 5-3/4" x 14" | |
| 2 | Wood Gussets | 5-1/2" x 27-3/4" | |
| 12 | 1x4 | Jig Blocks 18"-10" long approx. | |
| 2 | 3/8" | Gauge Blocks 3" x 8" | |