



Sentry Buildings

Assembly Book

Revised October 14, 2024



the Virginia

16'x32' Building

Manufactured by RBS Holdings, LLC

205 Arlington Drive

Greenville, PA 16125

This manual is copyrighted. Under the copyright laws, this manual may not be copied, in whole or in part, without consent from

RBS Holdings, LLC

© Copyright 2022

IMPORTANT INFORMATION ABOUT YOUR KIT

Building Permits: Check with your local HOA or building code office for any requirements, restrictions or permits necessary for construction.

Foundation: By owner. Refer to next page for foundation suggestions and size.

What's Included: Our package includes pre-cut materials for the 2nd floor roof gables, roof trusses and gable trim. See back page for material list. The nails and hardware are packed in the top of 'A' pallet. The other materials on the pallet will not be used until the first floor walls and loft floor are completed.

Framing lumber for the first floor walls and loft floor, exterior siding, loft flooring and roof sheathing will be delivered by a local supplier. See back pages for material list.

Owner Supplied: Walk-in man door, roof shingles, metal roof edge, felt and ventilation accessories. Paint for siding and trim. Additional lumber for framing additional window and door openings.

Assembly Help: Monday thru Friday 800-245-1577 8:00 to 5:00 ET
Weekend - after hours 724-866-4357
email to: help@barnkits.com

Care of product prior to assembly: Assembly should begin promptly to prevent the twisting of lumber. If assembly is not immediately after opening pallets you will need to tightly stack material and do not expose material to inclement weather. Organize all material prior to construction.

Building Tips: IMPORTANT: Follow the assembly Steps in sequence. Skipping steps will result in components not fitting properly.



Tools

Required:

- | | | |
|---|---|---|
| <input type="checkbox"/> Hand or Circular Saw | <input type="checkbox"/> Level | <input type="checkbox"/> Phillips Screwdriver |
| <input type="checkbox"/> Cordless Drill | <input type="checkbox"/> Measuring Tape | <input type="checkbox"/> Framing Square |
| <input type="checkbox"/> Caulking Gun | <input type="checkbox"/> 8' & 10' Ladder(s) | <input type="checkbox"/> Hammer |
| <input type="checkbox"/> Safetyglasses: Always wear safety glasses when cutting or nailing! | | |
| <input type="checkbox"/> * Scaffolding | | |

- * It is highly recommended to rent (6) six sections of scaffolding to safely install the second floor material. Use safety harnesses when on the scaffolding. Consider hiring a professional roofer to install the shingles or metal roof.

Foundation Types & Measurements

Important: You will need to have a proper foundation installed to support the building. Depending on the intended use determines what type of foundation is best.

Do Not make the foundation larger than the building size. When installing the building on a concrete slab, install the siding flush with the bottom plate. When installing on a wood floor, extend the siding 3/4" below the bottom plate to cover the edge of the flooring.

Foundation Types: What foundation is best depends on what type of items will be stored. The building code in your area will also determine what type of foundation can be used. A few different types of foundations are shown below. Check the zoning and building code requirements in your area.

Foundation Types

Floating Slab A concrete slab is ideal for storage of cars or other types of heavy items.

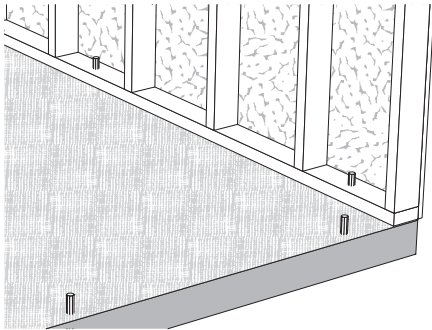

Floating Cement Slab

Wood Floor on Runners: Suitable for storage or workshop. Treated 6x6 lumber over a bed of gravel. Floor joist should be treated 2x6 spaced 16" on center and covered with 3/4" tongue and groove wood flooring.

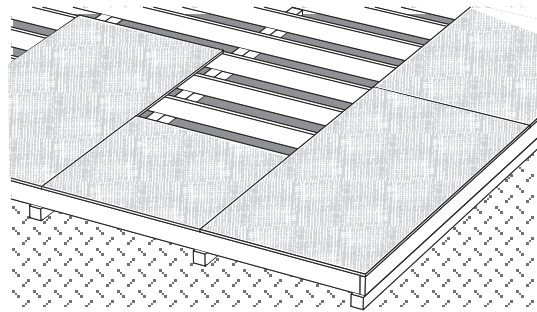

Wood Floor on Wood Runners

Exterior Siding Information

LP siding have a "LAP" and 'Tongue' Edge along the length of the sheet. When installing siding use 8d Galv. Box nails spaced 8" apart. Nail to all framing. Take care to not break the veneer skin of the siding.

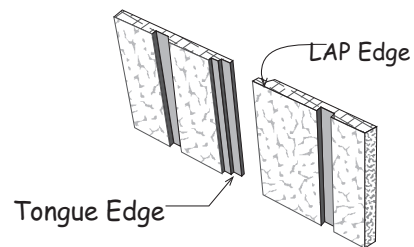

Rough Opening Details for Windows and Doors (not included)



If installing separately purchased windows and doors follow the manufacturers instructions for correct rough opening size. The below examples are for reference only and may need to be modified depending on style and size of your windows and doors..

Headers above windows and doors must be sufficient to support weight of 2nd floor and trusses. Wider spans require larger headers.

24" x 36" Window Opening

1. Select a wall stud where you want to start installing the window opening. Install another wall stud spaced 27" away.
 2. Cut (3) three 2x4s to a length of 40". Cut one to a length of 27".
 3. Install these 2x4s as shown on right.
 4. Cut (2) two 2x4s to 36". Install as header supports under header.
 5. Cut 2x4s to fit and install between header and top wall plate.
- * Maintain 16" stud spacing so the siding will meet on a stud.

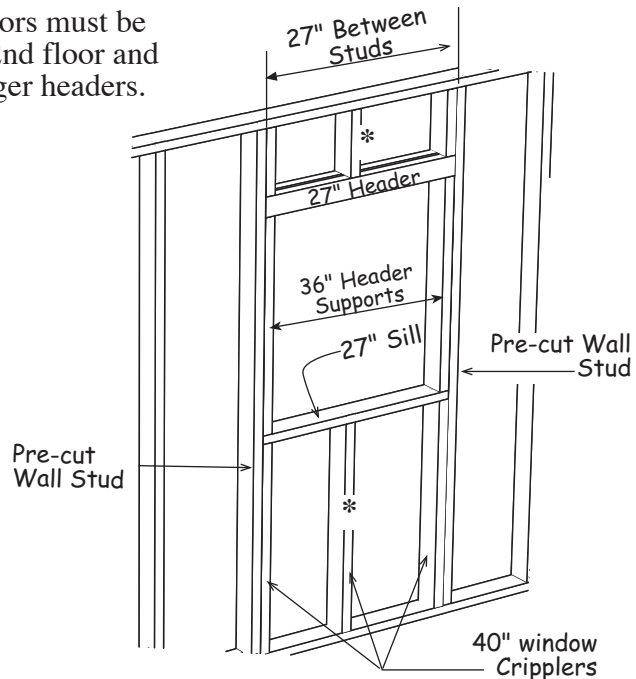

32" x 80" Door Opening

1. Select a wall stud where you want to start installing the door opening. Install a another wall stud spaced 37-1/2" away.
2. Cut (2) two 2x4s to a length of 80-1/2". Install these as header supports under header.
3. Cut 2x4s to fit and install between header and top wall plate.

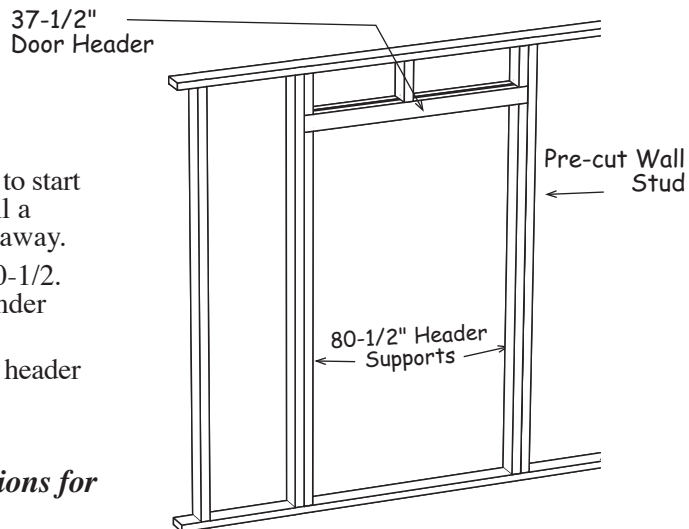

Alter the following instructions for rough openings as needed.

Step 1 Assemble (2) Two 92-1/2" Rear Wall Frames

1. Cut (2) two 2x4-8' (one will be treated) to a length of 92-1/2". Position the boards together and indicate with 'X' marks where the wall studs will be located.
2. Mark a 'C' anywhere between first two stud marks. This is referenced in a later step.

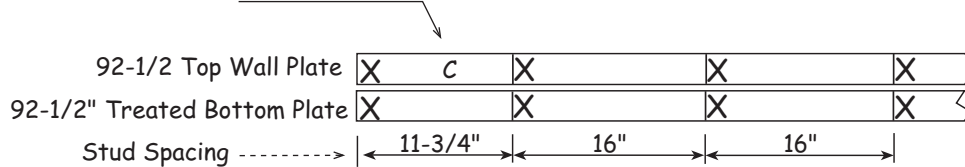

 **The length of pre-cut wall studs will vary from 92-1/4" to 93" depending on your locality.**

Note: When building the lower walls, use treated 2x4s for the bottom wall plates.

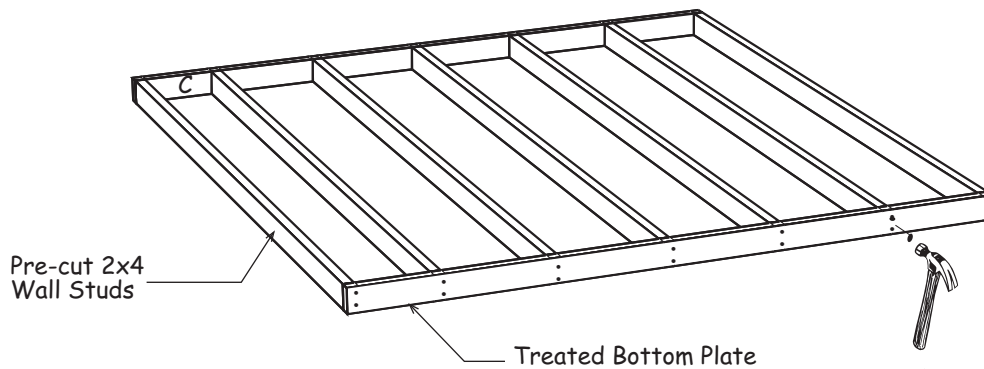

3. Install (7) seven pre-cut wall studs between the top and bottom plates. Nail the treated bottom plate to each wall stud with (2) two 16d galvanized deck nails. Use (2) two 10d coated sinker nails per stud to secure the top plate.
4. Repeat to build another 92-1/2' long wall frame.
5. Mark both frames **'Rear Wall Frames'** and set frames aside.

Step 2 Assemble (2) Two 8' Long Side Wall Frames

1. Select (2) two 2x4-8' (one will be treated) if necessary trim to a length of 96". Position the boards together and indicate with 'X' marks where the wall studs will be located.

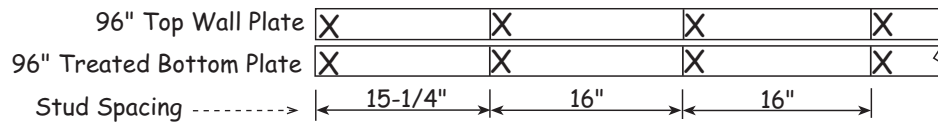

2. Install (7) seven pre-cut wall studs between the top and bottom plates. Nail the treated bottom plate to each wall stud with (2) two 16d galvanized deck nails. Use (2) two 10d coated sinker nails per stud to secure the top plate.
3. Repeat to build another 8' long wall frame.
4. Mark the frames '**Side Wall Frames**' and set frames aside.

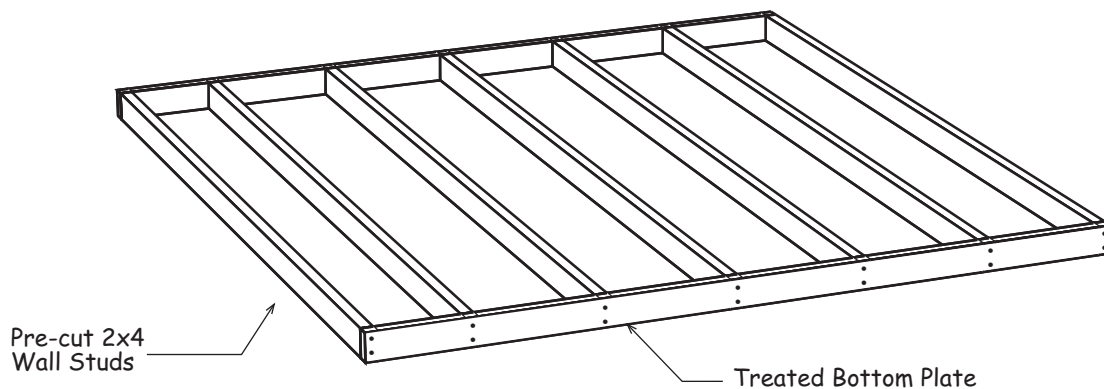

Step 3A Assemble (4) Four 12' Side Wall Frames

1. Trim, *if necessary*, (2) two 2x4-12' boards (one will be treated) to a length of 144". Position the boards together and indicate with 'X' marks where the wall studs will be located.

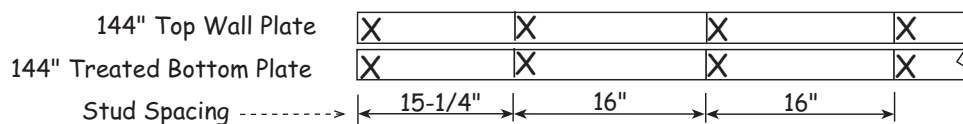

Step 3B Assemble (4) Four 12' Side Wall Frames continued

2. Install (10) ten pre-cut wall studs between the top and bottom plates. Nail the treated bottom plate to each wall stud with (2) two 16d galvanized deck nails. Use (2) two 10d coated sinker nails per stud to secure the top plate.
3. Repeat to build (3) three more 144" long wall frame.
4. Mark both frames '**Side Wall Frames**' and set frames aside.

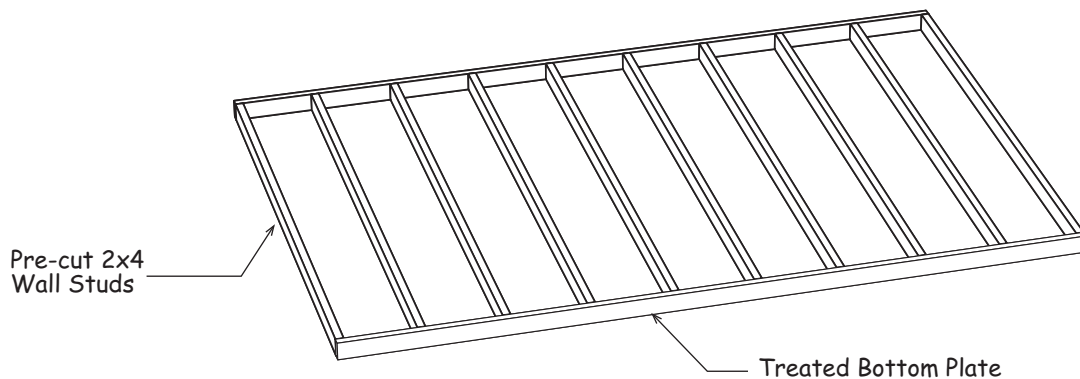

Step 4 Assemble Door Header

1. Cut (2) two 10' long 2x8 boards to a length of 99".
2. Locate a 24" x 48" OSB (oriented strand board) panel packed in our kit. Cut (2) two 7-1/4" x 48" fillers to fit between the 2x8 boards. OSB will be 1-1/2" from either end.
3. Take OSB filler and install in the center of the 2x8 boards. Nail together using 10d coated sinkers. Use (12) twelve nails spaced evenly on each side.

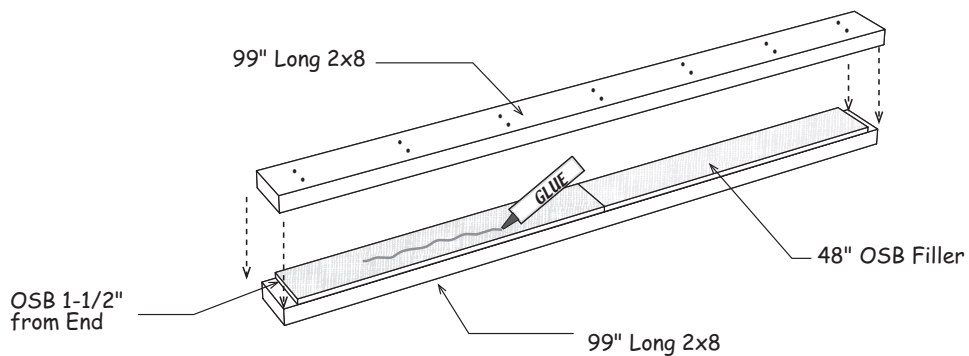

Step 5 Assemble 15'-5" Front wall Door Frame

 **Instructions show a suggested location for a 24"x36" window.** Adjust stud spacing if no window or if a different size window was purchased. A walk-in door can also be installed if desired.

1. Cut (2) two 2x4-16' (one will be treated) to a length of 185". Position the boards together and indicate with 'X' marks where the wall studs will be located and an 'S' where the door header support studs will be located.

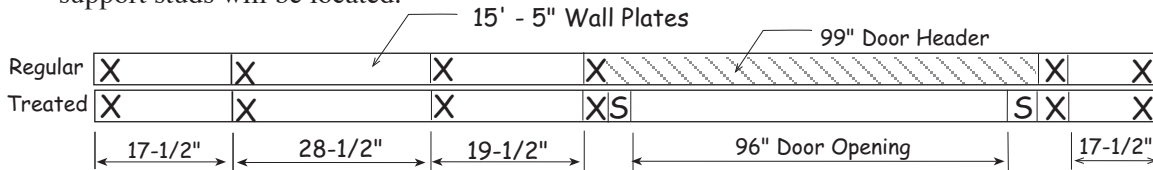

 When setting the wall panels the door opening can be positioned on the right, as shown below, or reverse framing to position on the left end of the wall.

2. Assemble the front wall frame using the wall plates cut above and install (6) six pre-cut wall studs over the 'X' marks.
3. Cut (2) two pre-cut studs to a length of 82" and install them as header supports using (10) ten 10d sinkers. Install the 2x8 header by toe-nailing the ends to the adjacent studs with 10d sinkers.
4. Cut (5) five pieces from a pre-cut stud to fit between header and top 2x4 plate. Install with 10d sinkers through top plate and toenail into header. Save cutoff for next step.
5. Cut (3) three 2x4s to 40". Nail one board to 2nd stud and bottom plate. Nail another 40" board next to first 40" board. Install last 2x4 to 3rd stud and bottom plate.
6. Cut (1) one 2x4 to 27" as a sill plate and (2) two 2x4s to 36" as header supports. Install as shown. Install header above 36" boards. Cut (3) three 2x4s to fit between header and top plate.

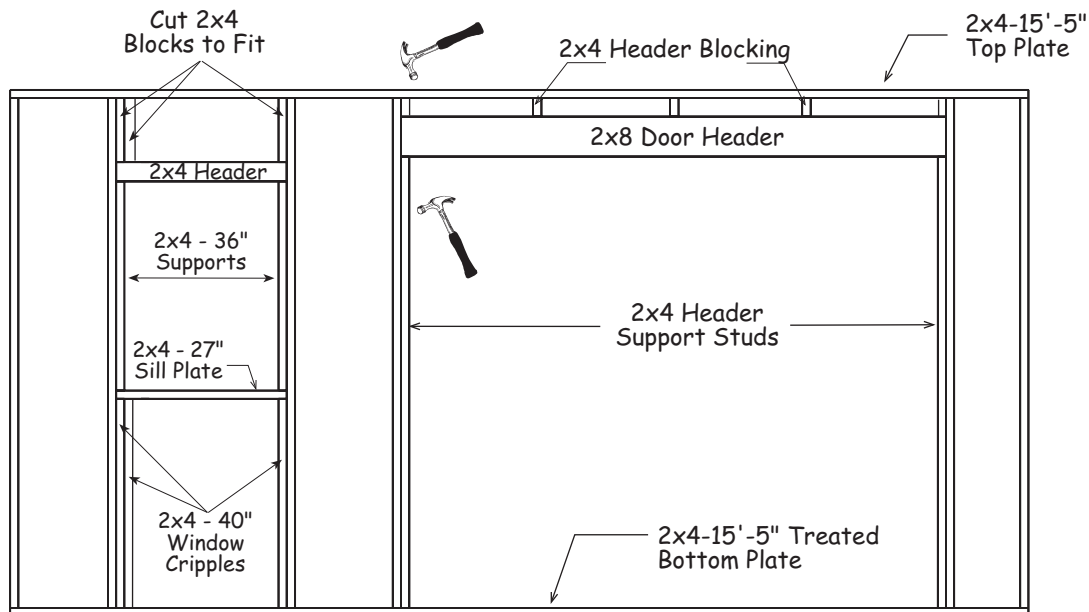

Step 6 Set Wall Frames

 *Front and back wall frames are positioned between long side walls.*

1. Install one of the 92-1/2" rear wall frames against inside of a 8' side wall frame. Brace walls with pre-cut studs. **IMPORTANT:** Orient end marked with a 'C' to corner. Secure frames together at the corner using (4) four 10d sinkers
2. Install the other 92-1/2" rear wall frame to the rear wall frame. Nail the rear wall frames together where they butt with (8) eight 10d sinker (stagger nails on each side of the studs) .
3. Install a 12' frame, next to the first 8' side wall frame. Nail frames together where they butt with (8) eight 10d sinkers (stagger nails on each side of the studs).

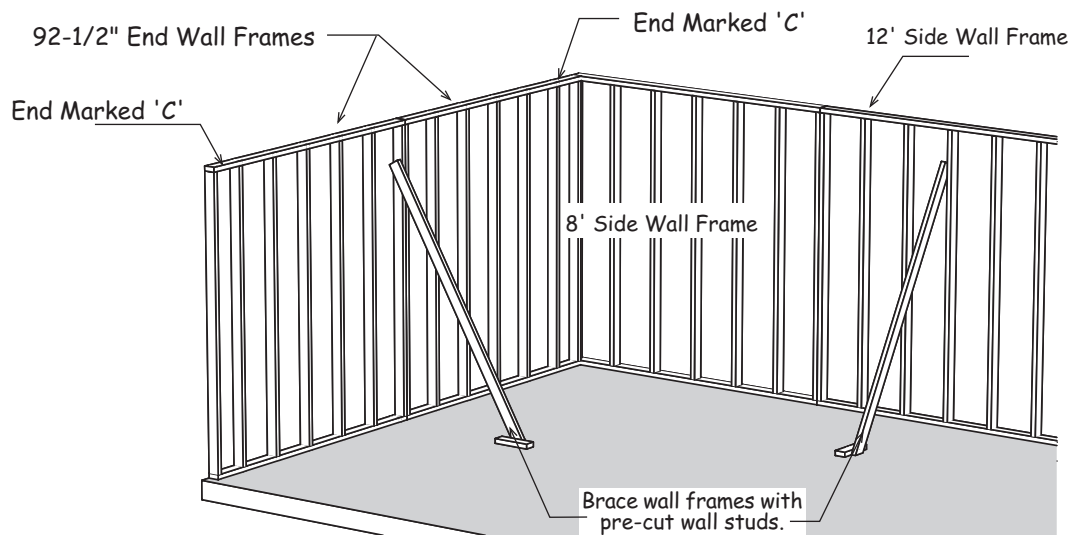

4. Install another 12' long side wall frame.
5. Install opposite side wall frames.
6. Install the front wall frame between the side wall frames. Turn the wall frame around if you want the window located on the right. Secure frames together at the corner using (4) four 10d sinkers.
7. Nail frames to the floor using 16d Galv. spiral nails or, if erecting on a cement slab, concrete anchor bolts (*not included*) spaced 24" on center. Do not nail the 2x4 plate in the door opening.

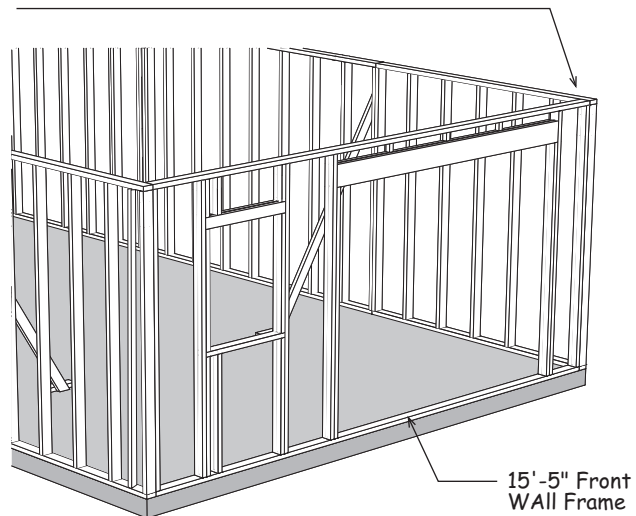

Step 7 Install 2x4 Tie Plates

1. Install a 16' long 2x4 on the back wall. Use 10d sinkers space 16" apart to secure tie plates.
2. Repeat to install a 16' long 2x4 tie plate on the opposite front wall.

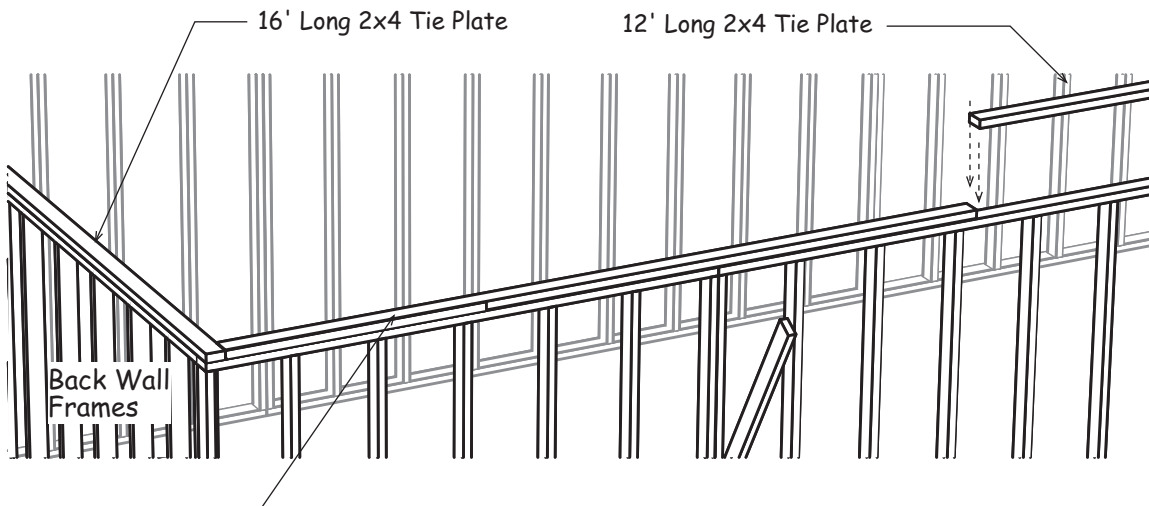

3. Install a 2x4-12' on the side wall. The 2x4 will butt against the 16' long tie plate on the back wall. Use 10d sinkers.
4. Install another 2x4-12' boards on the same side wall frame.
5. Cut to fit and install a 2x4-8' board to finish.
6. Repeat to install 2x4 tie plates on the opposite sidewall frames.

Step 8A Install Siding on Wall Frames



If a siding panel has a damaged edge, install this edge at a corner where it will be covered with corner trim.

Concrete Slab Foundation: Install siding flush with the bottom plate.

Wood Floor Foundation: Extend the siding 3/4" below the bottom plate.

Exterior Siding Information

LP siding is primed ready to paint. Apply two coats of latex acrylic paint for the finish coat. Paint the bottom edge of the siding, *this is important*. Maintain 6" to 8" of clearance from the bottom edge of the siding and the ground. Don't allow garden mulch to build up and keep shrubs a minimum of 1' away from the building.

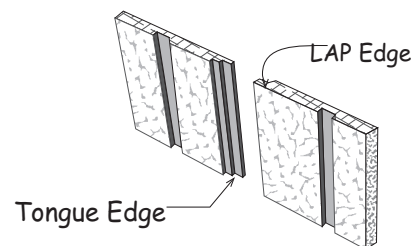

Step 8B Install Siding on Wall Frames continued

1. Install a full width siding panel on the side wall with the 'LAP' edge flush with the 2x4s on the back wall. Install (7) seven more siding panels. If necessary cut last panel flush with 2x4s on front wall. Use 8d galv. box nails spaced 8" apart.
2. Install a siding panel on the back wall with the 'LAP' edge flush with the siding on the side wall. Install 3 more panels.

3. Install siding on opposite side wall.

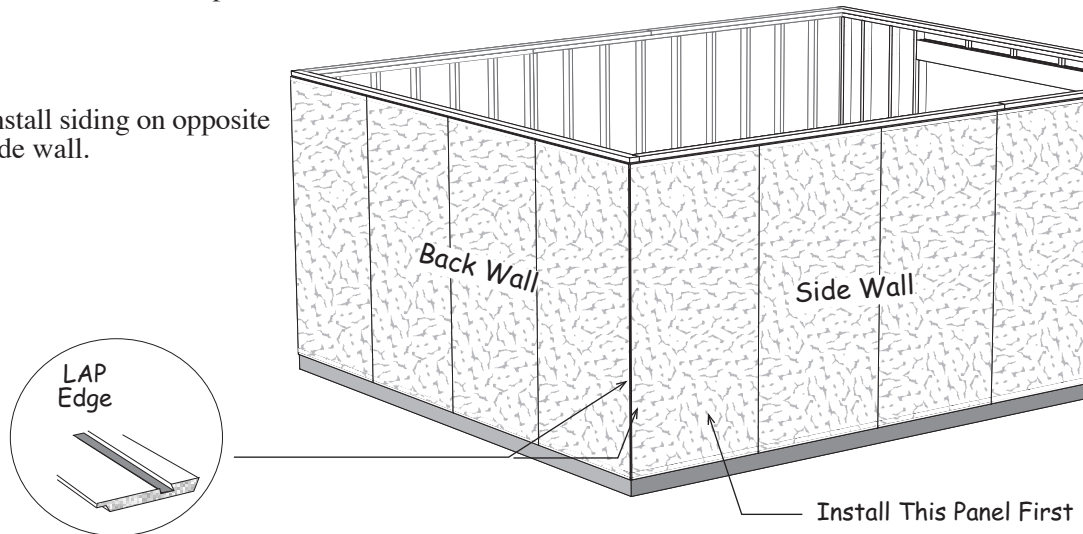

 If suggested 24"x36" window was **NOT** installed adjust width of first siding accordingly.

4. Measuring from the 'tongue' edge, cut a siding panel to a width of 28". Install this siding panel on the front wall with the 'cut' edge flush with the siding on the side wall. Cut and remove the siding that extends over the window opening.
5. Install a 4x8 siding panel. Remove siding that extends over the window opening.
6. Locate (2) two 14-1/2" x 48" siding panels. Cut these to fit above door opening with bottom edge 3/4" below door header.
7. Install the remaining siding panel on the wall frame.
8. Cut and remove 2x4 plate that extends across the door opening. Save the 2x4, it will be used in a later step.

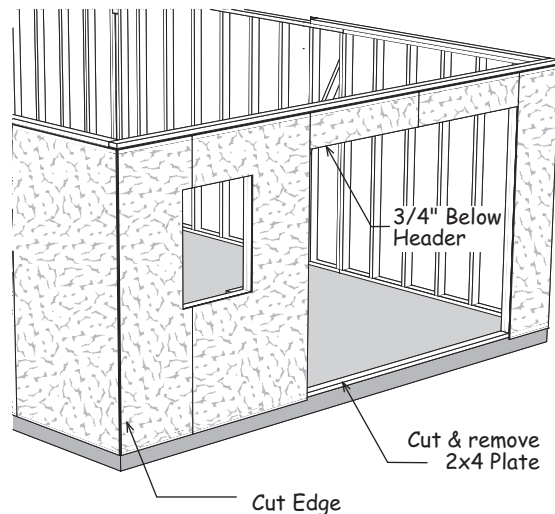

Step 9 thru 11



Steps not needed with this size and model.

Step 12 Install Stairs



IMPORTANT: Go now to the instructions in the stair kit book to install the stairs, floor joist and flooring.

Step 13A Assemble Rear Gable

 Assemble the roof gables and trusses on the center of the loft floor. This will make it easier to stand the gable upright over the lower wall.

1. Cut (2) two 2x4-10' boards to a length of 97-1/2". Position these 2x4s, *on edge* and butt together.
2. Position (2) two 81-3/4" long 2x6s and (2) two 71-3/8" long 2x6 boards on the 2x4 plates as shown below. The top 2x6 boards have blue marks on the ends. Position these ends together at the top.

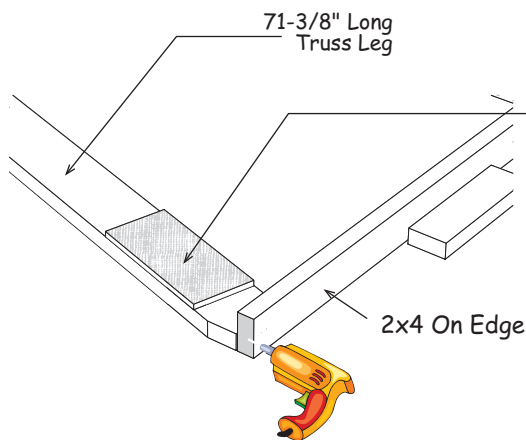
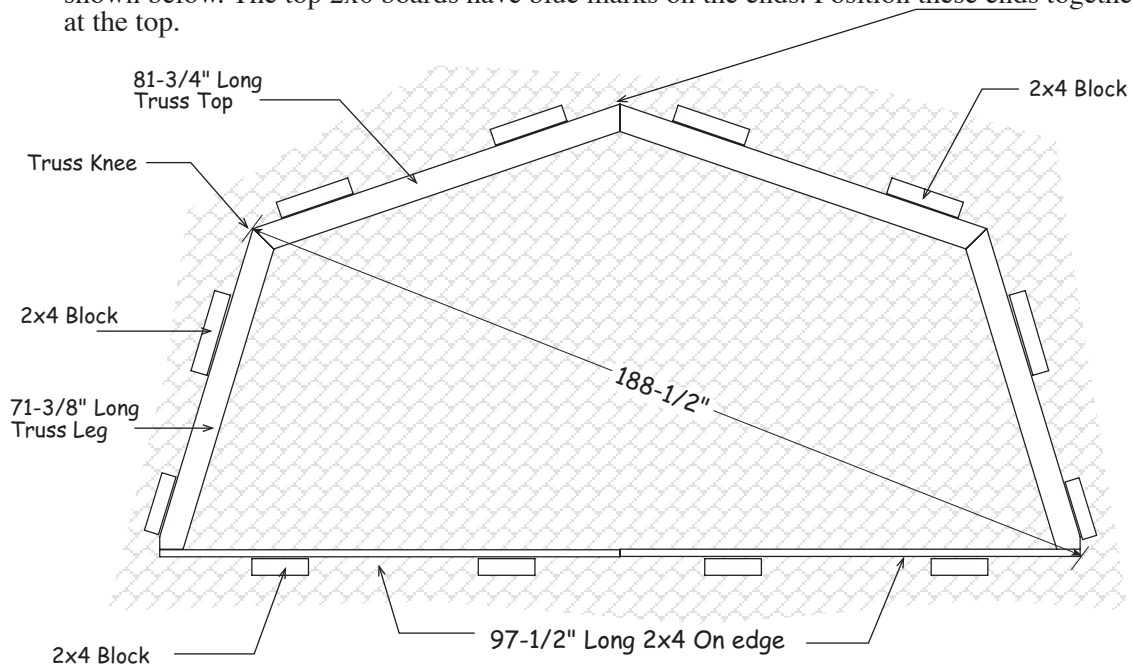

3. Secure the truss leg to the 2x4 plate with (2) two 2-1/2" long deck screws.
4. Install 5-1/2" x 12" OSB fillers on the 2x6 truss legs near 2x4 with 6d common nails. Exact spacing isn't important.
5. Square truss. Measure diagonally from the knee of the 2x6 truss to the bottom corner of the 2x4 plate. The measurements will be the same (188-1/2") when the truss is square.
6. Cut 2x4 removed from door opening into 8" long blocks. Tack nail or screw the blocks around the perimeter of the gable frame to prevent the gable from moving.

Step 13B Assemble Rear Gable continued

 *Two Ridge Gussets have equal angles cuts. Four Knee Gussets have offset angles cuts.*

1. Secure the 2x6 boards together at the knee and ridge with 1/2" OSB gussets. Use 6d common nails. Nail 5-1/4" x 12" OSB fillers where shown below.

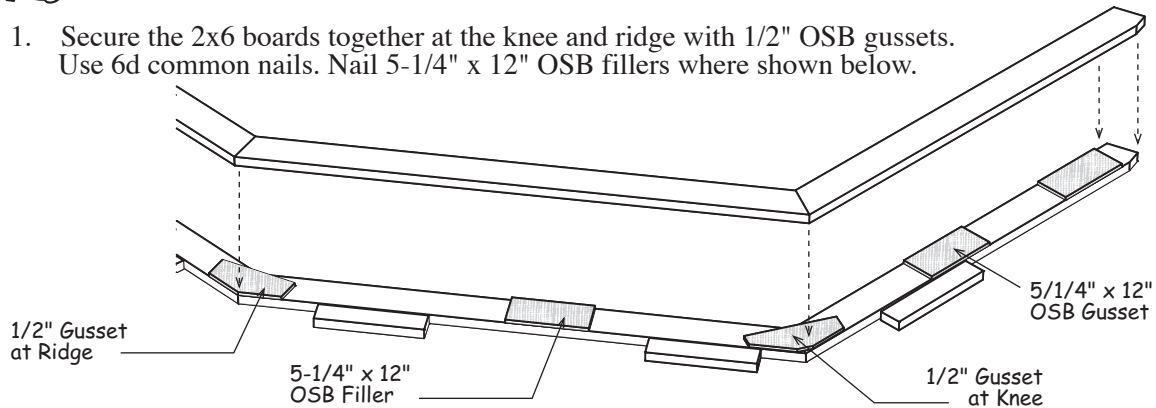

2. Place (2) two 81-3/4" and (2) two 71-3/8" 2x6s over the fillers. Secure using (6) six 10d sinkers where fillers and gussets are located.
3. Install a 21-3/4" high pre-built gable frame at the peak of the double row of trusses. Secure the frame to the 2x6 truss boards with (6) six 2-1/2" deck screws.
4. Position a 19-1/4" pre-built frame directly below the top frame. Use (2) two 80-1/2" long studs to help align the upper and lower frames. Use a framing square to ensure the studs are plumb. Screw bottom frame to 2x4 plate using 2-1/2" screws. Secure the 80-1/2" studs to the pre-built frames using 2-1/2" screws.

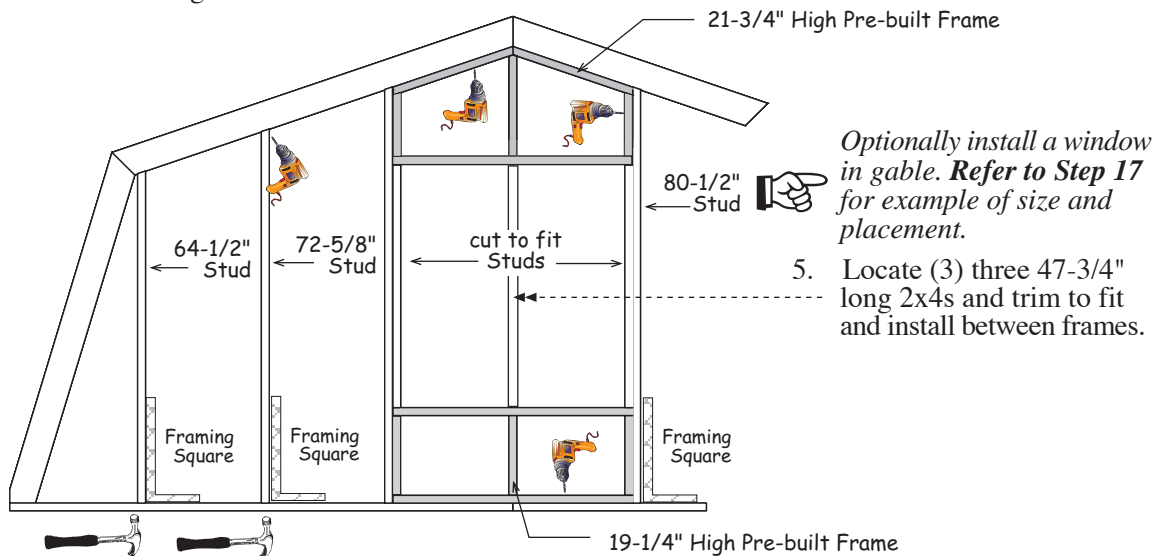

5. Locate (3) three 47-3/4" long 2x4s and trim to fit and install between frames.
6. Install a 72-5/8" and a 64-1/2" wall stud on the left side of the gable frame. Use a square to ensure the studs are plumb. Nail to 2x4 bottom plate with 10d sinkers and screw to 2x6s with 2-1/2" screws. Repeat to install studs on right side of gable frame.

Step 14 Install Siding on Rear Gable Frame

1. Stand up the gable frame and slide it to the rear of the building. Position the frame with the bottom towards the rear wall so it can be erected after the siding is applied.
2. Install a pre-cut siding panel with the 'cut edge' flush with the left side of the gable frame. The siding should extend $\frac{3}{4}$ " below the bottom 2x4 gable plate. Install siding with 8d galv. nails.
3. Install (2) two 4x8 siding panels. Cut and remove siding that extends above the top of the gable frame.
4. Install 80-1/2" long siding panel. Cut the siding that extends beyond the gable frame.

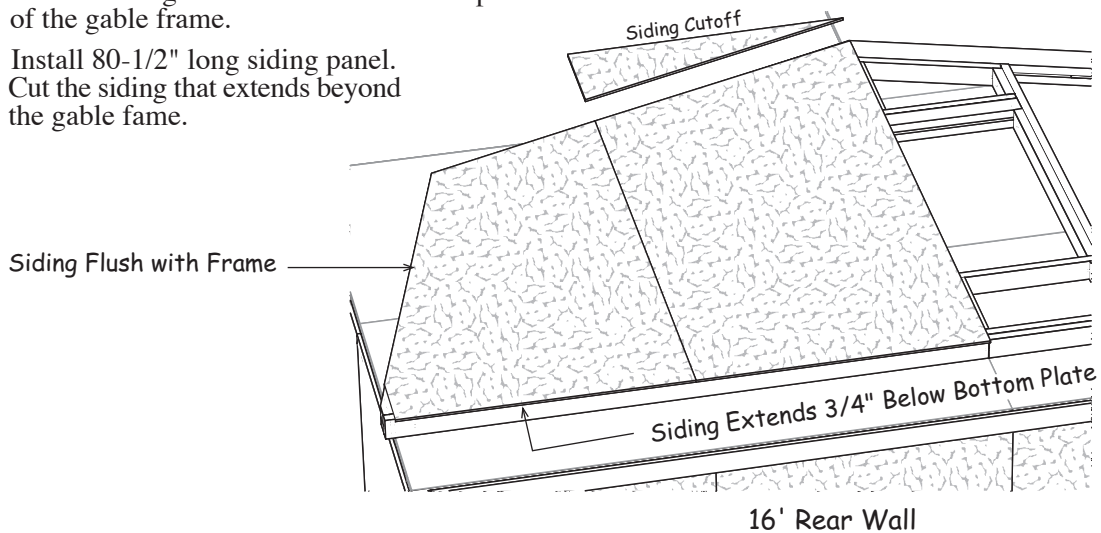

Step 15 Install Trim on Front and Back Walls

IMPORTANT: Trim Must Be Installed Before Installing Roof Gables!

 All trim is installed using 8d galvanized box nails spaced 12" apart.

1. Locate (4) four 1-1/2" x 48-3/4" siding filler strips. Install these on back wall flush with top of flooring. There may be a gap between top of siding and strips. Use a few 8d galv. nails. Additional nails are applied below.
2. Cut and install (2) two 1x4 -10' trim boards flush with top of floor and bottom of the siding. Install trim flush with the siding on the side walls. Use 8d galv. nails spaced 12" apart.

3. Install (2) two 96" long 1x4 trim boards between corner boards. Trim should be flush with the loft floor. Cut 2nd board to fit.
4. Repeat to install trim to the front wall panel.

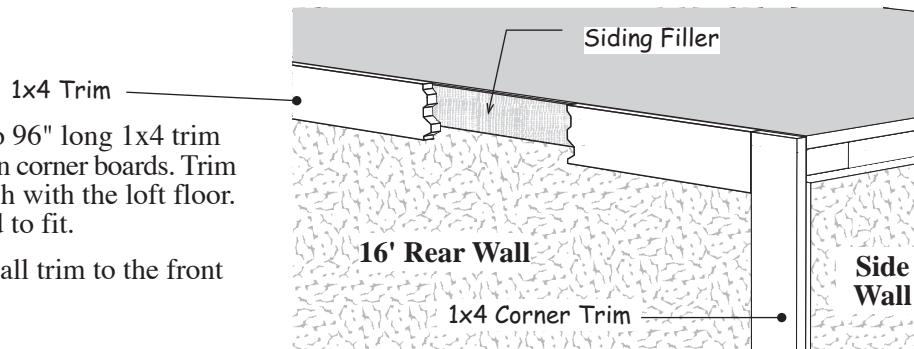

Step 16 Install Rear Roof Gable

1. Install (2) two 2x4-12' boards on the back wall to prevent the gable from falling off during gable installation. Install (2) two more 2x4-12 boards to brace the vertical 2x4 in place.

Before bracing the vertical 2x4s in place attach (2) two 2x4 blocks to the back of the 2x4s. This will create the proper spacing to set the gable over the lower wall.

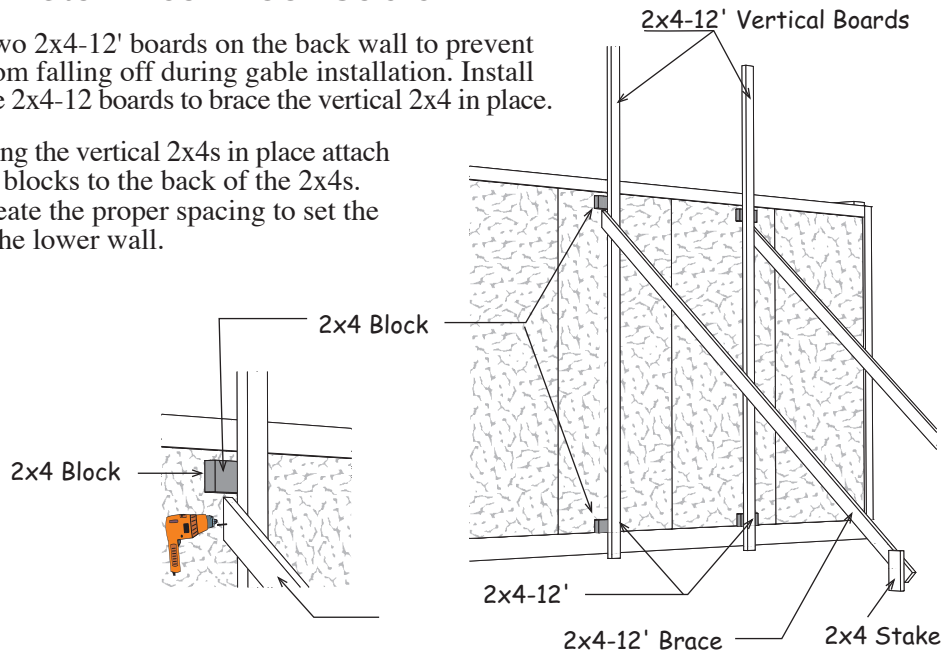

2. Erect the gable on back wall. Be cautious and ensure gable siding extends over trim on back wall. Center gable with bottom 2x4 extending 1-1/2" past lower wall 2x4s on both sides. Nail to floor using 10d sinkers.
3. Remove the wall braces from interior walls and use them to brace the gable to the loft floor.

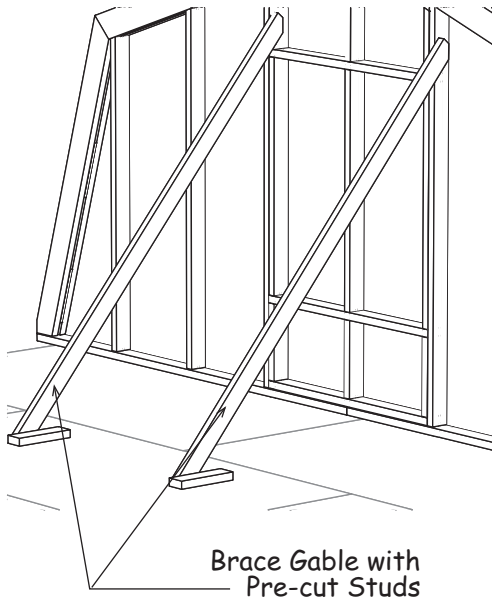

4. Nail bottom edge of siding to 1x4 trim with 8d galvanized box nails.

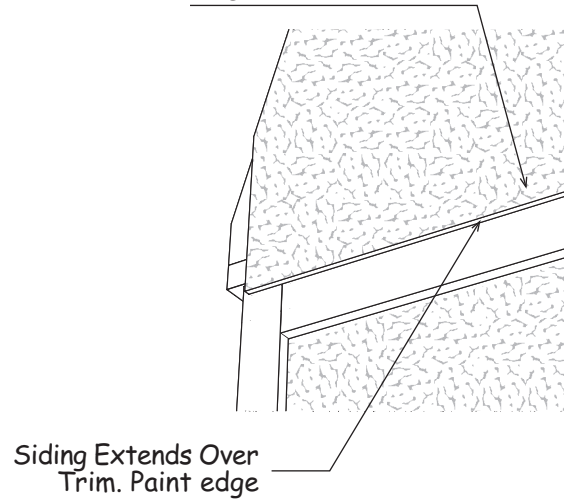

Step 17 Assemble & Install Front Gable

 **Instructions show a suggested location for a 36"x36" window.**
Follow Steps 13 - 14 to build without a window.

1. Repeat **Step 13** to assemble front gable. Alter stud framing for window opening. Locate (3) three 47-3/4" long 2x4s. Cut (1) one to 36". Position these boards as shown below. Measure distance to bottom gable frame and cut (3) three 2x4s to this length and install under 36" board. Install 2x4s with 10d sinkers.
2. Slide gable to the front of the building. Position the frame with the bottom towards the front wall so it can be erected after the siding is applied.
3. Repeat **Step 14** to apply gable siding. Cut and remove siding from the window opening.
4. Remove the 2x4-12' boards used for bracing on back gable and repeat **Step 16** to install the front gable.

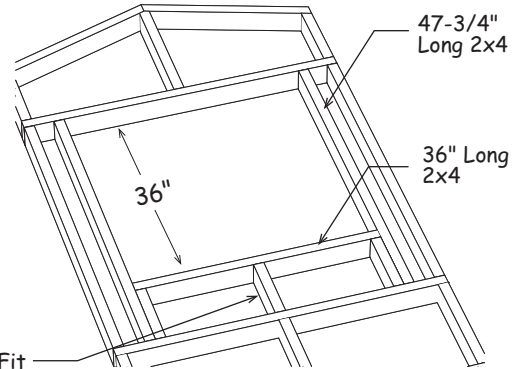

 **Do not remove 2x4 blocks from floor.**
They will be used to assemble trusses. Cut to Fit

Step 18 Install 2x6 Truss Plates

1. Install (3) three 2x6-7' and (1) one 2x6-12' as truss plates between the front and rear gable wall panels on each side wall. Cut the last 2x6 to fit. The 2x6 plates should project 1-1/2" past the 2x4 tie plate (see Detail 'A'). Nail 2x6s to the floor with 10d coated sinker nails; double row spaced 16" apart.
2. Starting at the rear gable indicate with 'X' marks where the trusses will be located. The last space will be wider than the first (19-3/8") space.

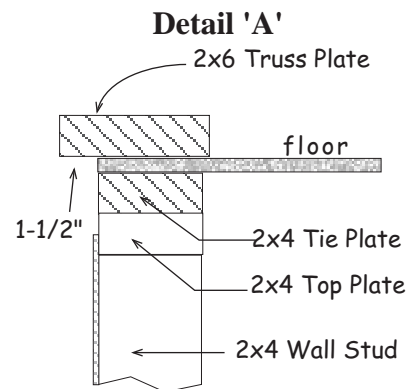
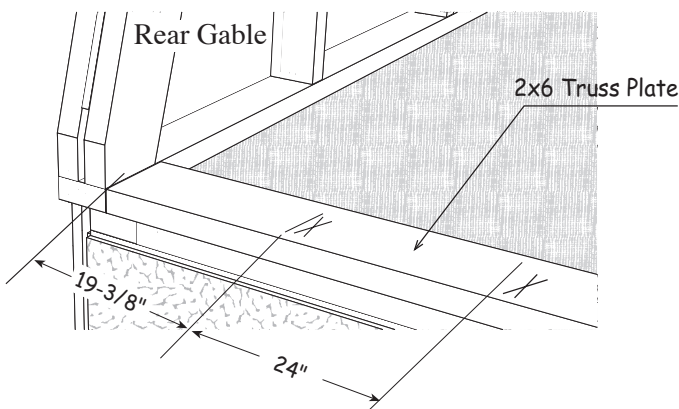
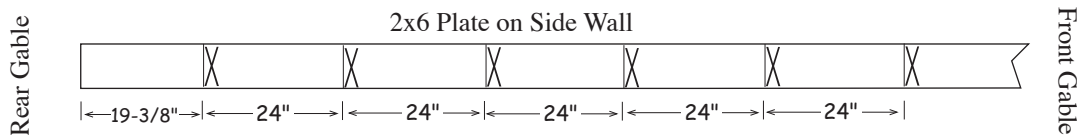

Step 19 Install 2x6 Soffit Blocks

1. Locate (4) four pre-built 2x6 soffit blocks with siding attached. Starting from corner of the back wall position a soffit block with attached siding under bottom plate of gable and flush with face of gable siding. Secure to wall using (2) two 3" deck screws.
2. Locate 10" long pre-built 2x4 soffit blocks. Locate the third stud from the corner on the back wall. Center a soffit block over this stud with the 5" wide side facing down. Bottom of soffit block should be 10" from the underside of the 2x6 truss plate. Secure to stud with (2) two 3" deck screws. TIP: Use a 2x6 soffit block with siding as a gauge for proper distance.
3. Continue installing soffit blocks on every other stud down the length of the wall.
4. Install last block with attached siding flush with face of front gable siding.
5. Repeat on opposite wall.

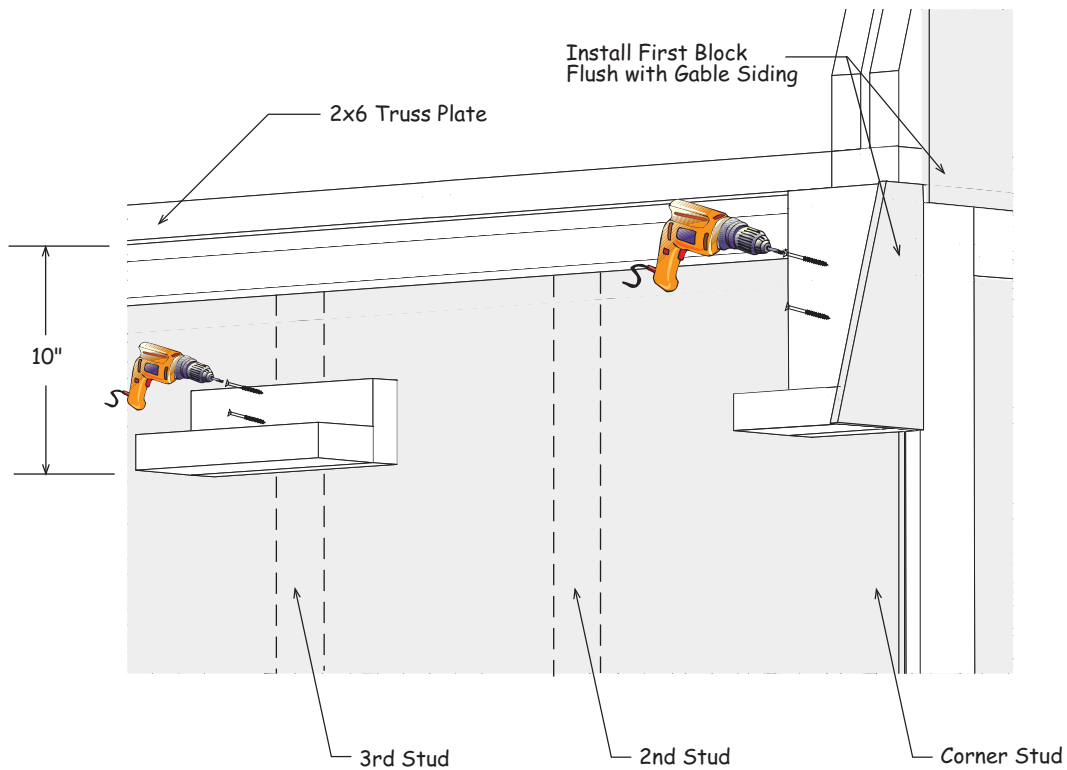

Step 20 Assemble Roof Trusses

1. Lay truss parts inside the 2x4 blocks used around gable frames. One end of the 81-3/4" long 2x6 boards have a blue mark. Place these ends together at the ridge. Add a 2x4 block at the bottom of the truss legs to keep this 2x6 from moving.
2. Secure the 2x6 boards together using pre-cut gussets. Knee gussets are 30" wide. Ridge gusset is 31-3/4" wide. Take the gussets and the 2x6 boards and secure gussets with (3) three rows of 6d common nails spaced 6" apart. **Important**; when installing the gusset at the knee, install gusset with the shortest angled side towards the ridge. *See detail at bottom of page.*
3. Turn truss over and apply gussets to the other side. Set truss aside.
4. Assemble (14) fourteen more trusses. Remove 2x4 blocks from floor.

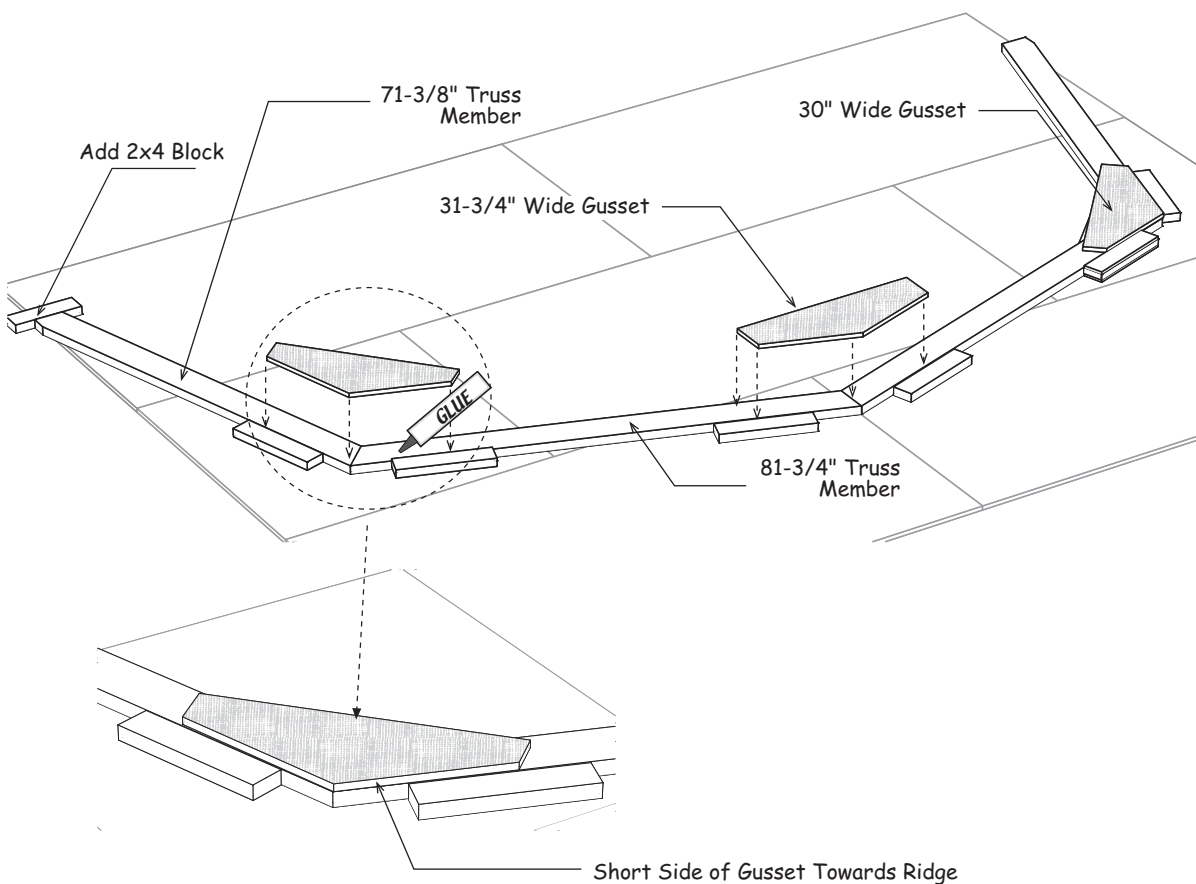

Step 21 Install Roof Trusses

1. Install 2x6 hangers over the 'X' marks on the truss plate and flush with outside edge of 2x6. Use 1-1/2" joist hanger nails. Set truss legs into hanger. Use 10d coated sinker nails to secure the truss to the metal hanger (use hanger eyelets to guide the nails at the correct angle).

2x4-12' Board

2. Remove the 2x4-12' boards used to brace the front gable. As you progress setting trusses tack these boards to keep trusses plumb. Don't remove the 2x4s until the roof sheathing is applied.

2x6 Metal Hanger

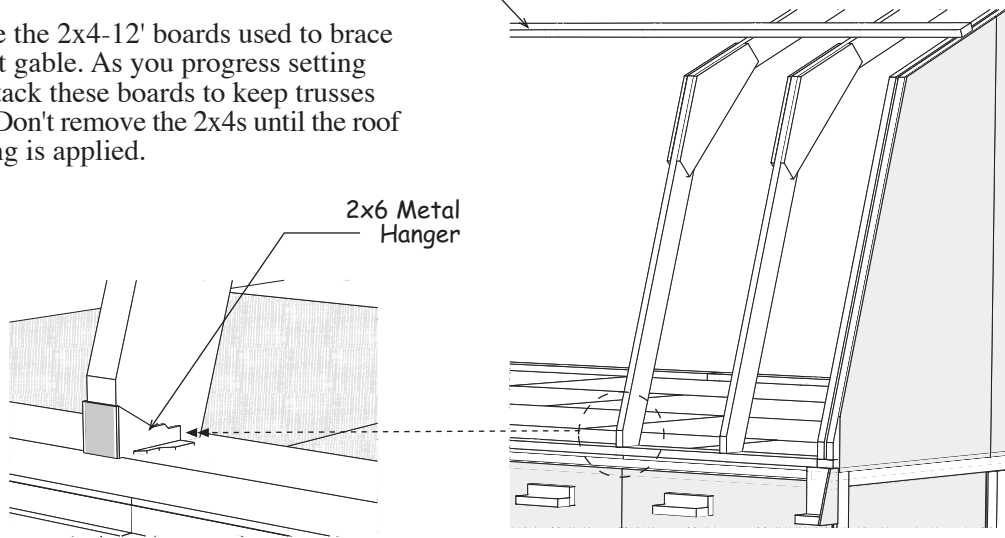

Step 22 Install Soffit & Corner Trim

1. Gather (10) ten 5-1/2" x 48-3/4" primed soffit panels. Select (1) one soffit panel and measure from 'Tongue' edge and cut to a length of 33". Install primed side down with cut edge flush with face of siding on first soffit block. Secure to each block using (2) two 1-1/4" stainless trim screws.
2. Install full length soffit panels along the side wall. At every other seam secure a short 2x4 from cut offs with trim screws. Cut the last soffit panel flush with the face of siding of last soffit block.
3. Install soffit panels on the opposite wall.

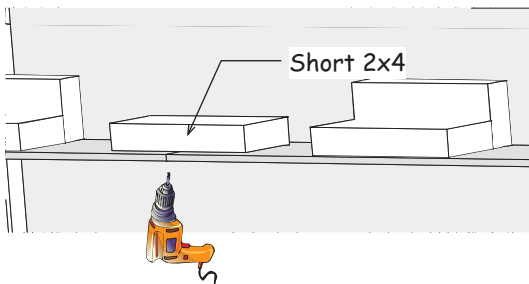
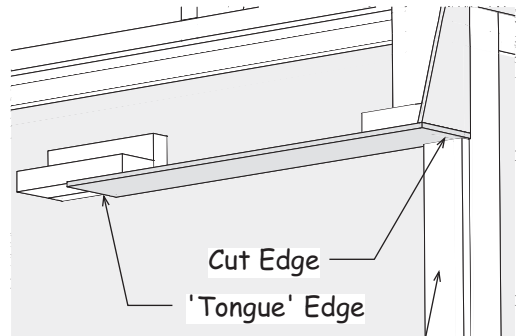

4. Install (4) four 1x4 corner trim under soffit on side walls flush with front and back wall trim. Cut 1x4-8' trim boards flush with the bottom of the siding.

Step 23 Install Front Gable Soffit

1. Install 81-3/4" long 2x4s on the top of the front gable, flush with the top of the gable frame. Install the ends with the blue mark together at the peak of the gable. Use 10d sinkers spaced 12" apart.
2. Install 82-5/8" long 2x4s on the side of the front gable, flush with the side of the gable frame.
3. Install (2) two 8" wide x 48-3/4" soffit panels under the 2x4s with primed side down and the 'LAP' edges together at the knee of the gable. Use 1-1/4" stainless trim screws spaced 12" apart.

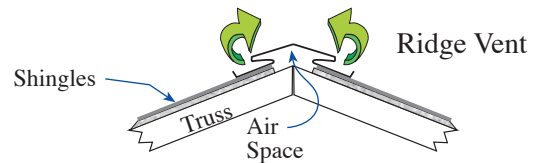
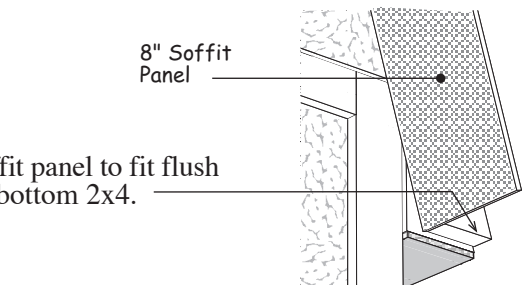
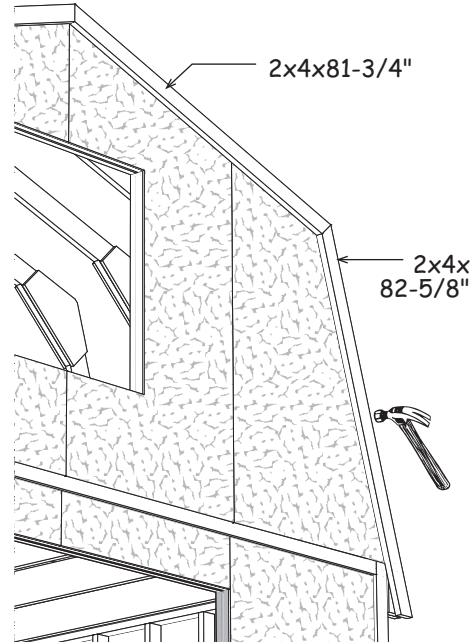
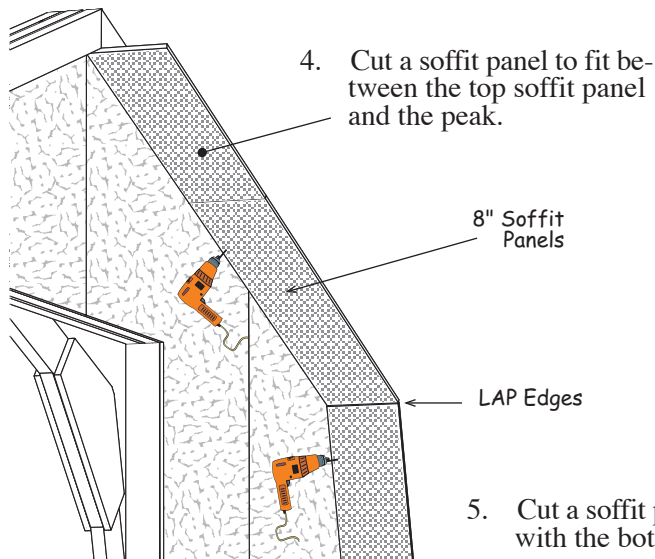

Step 24A Install Roof Sheathing

1. Refer to next page for the proper layout of the 7/16" OSB sheathing. Make certain the trusses and the gables are plumb. Install a plyclip between each truss on the top row of sheathing. If you are installing a ridge vent, cut the top row of roof sheathing 1" below the peak of the truss to allow air circulation through the ridge vent. *See detail above.* Install sheathing using 6d common nails spaced 9" apart.

Step 24B Install Roof Sheathing continued

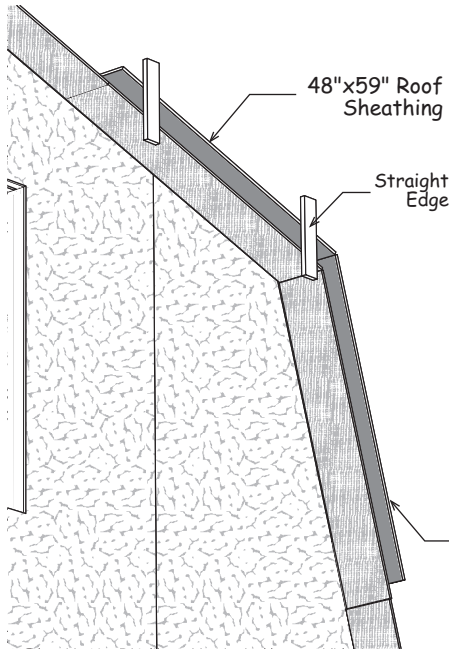

2. Cut (2) two 48"x96" OSB sheets in half to make (4) four 48"x48" sheets. Re-cut one to 36"x48".
3. Starting at gable knee install roof sheathing at the front of the building, *refer to the sheathing layout below*. Using a straight edge position the first sheets plumb with the soffit panels. The roof sheathing should meet at center of the trusses.
4. Cut OSB flush with back gable siding.
5. Cut 48" wide sheets to 36" and install on bottom row per layout.
6. Cut 48" wide sheets to fit on top row. Or, cut 1" narrower to allow for venting. Install (1) one plyclip between each truss for this row.
7. Repeat on opposite side of building.

48"x83" Roof Sheathing

Upper sheathing should rest on lower sheathing



Plyclip

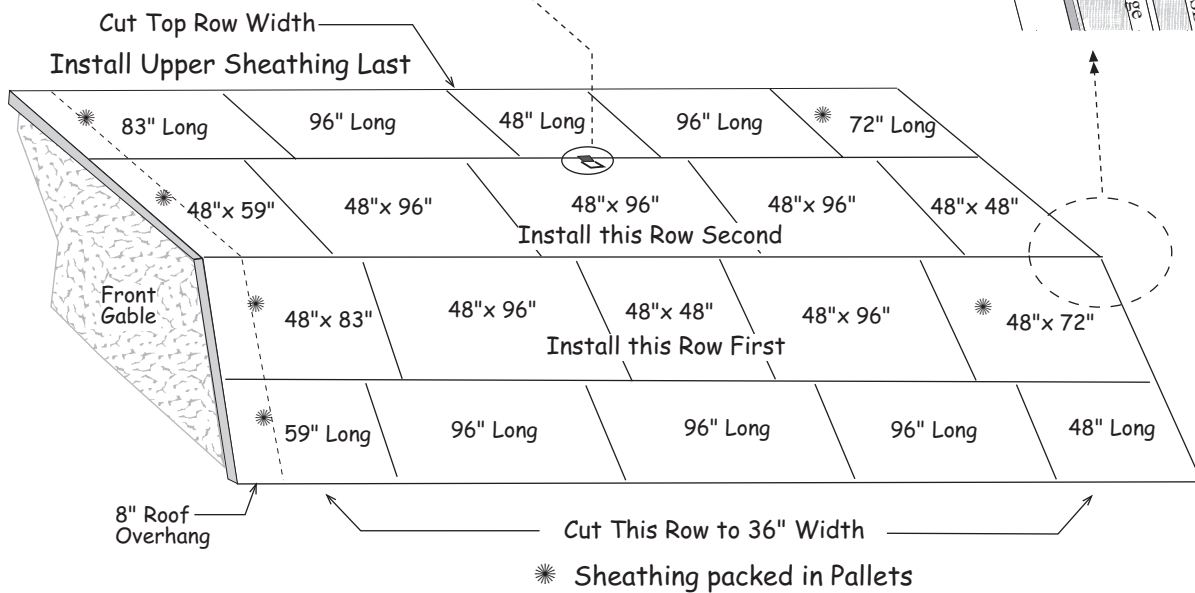
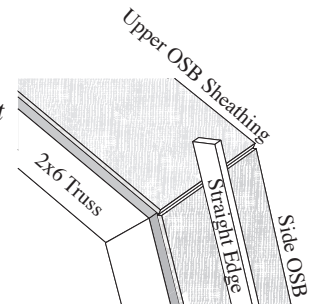

Step 25 Install Front Gable Trim

1. Insert a 81-3/4" long 2x4 between the soffit panels and the roof sheathing on the upper gable. Use 1-1/4" trim screws to secure the soffit panels to the 2x4s. Use 6d common nails to secure the roof sheathing to the 2x4s.
2. Insert and secure 82-5/8" long 2x4s between the soffit panels and the roof sheathing on the side of the gable.

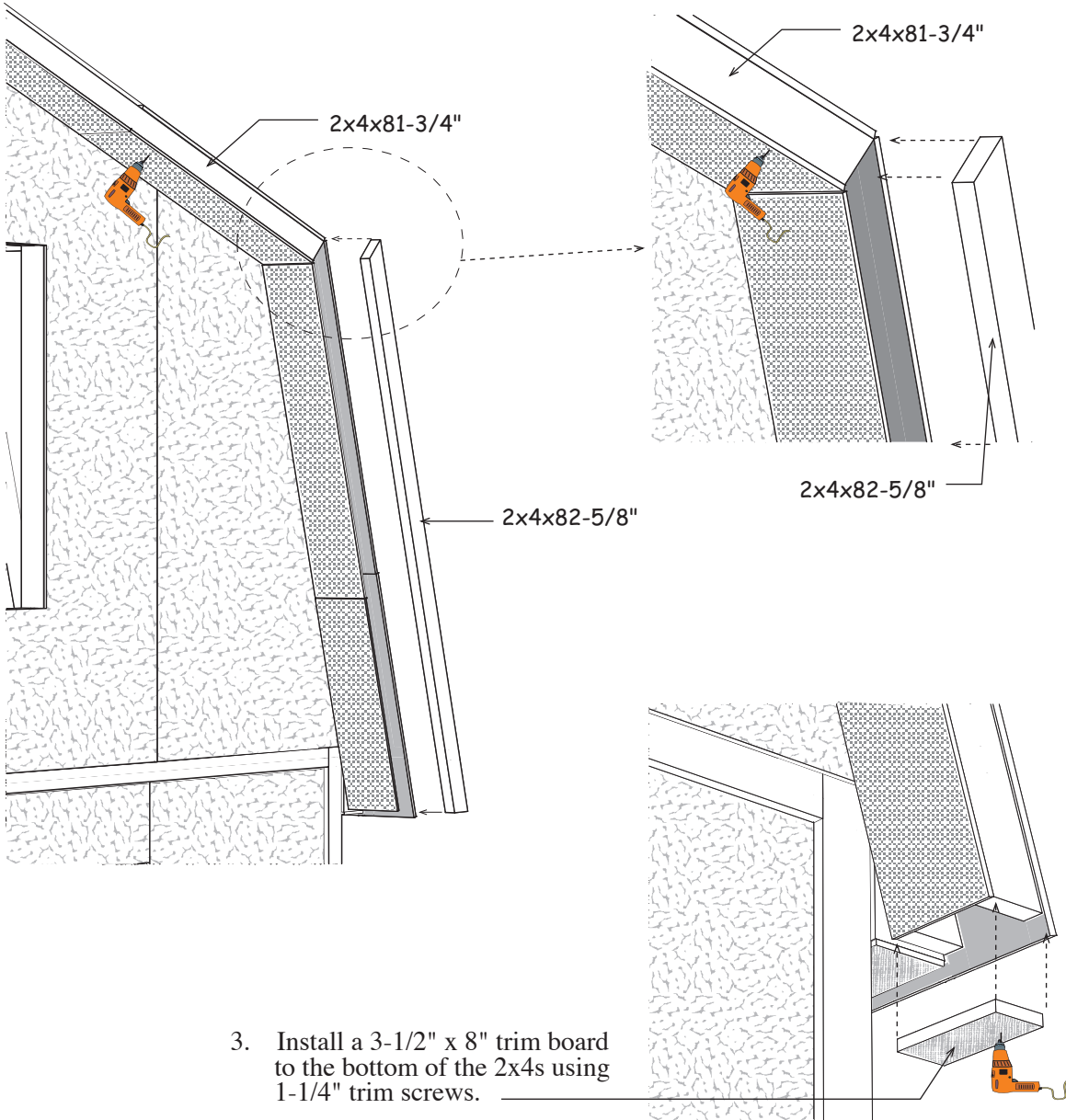

Step 26 Install Front Gable Trim continued

4. Install 82-1/4" long 1x6 trim boards at the top of the gable. Install the end with the blue marking at the ridge. Install 1x6 flush with the top of the roof sheathing. Use 8d galv. nails.

82-1/4" long 1x6 Trim

5. Install 84" long 1x6 trim boards at the side of the gable, flush with the roof sheathing.

82-1/4" long 1x6 Trim

6. There is no overhang on the back gable. Apply trim directly to the siding flush with top of OSB roof sheathing.

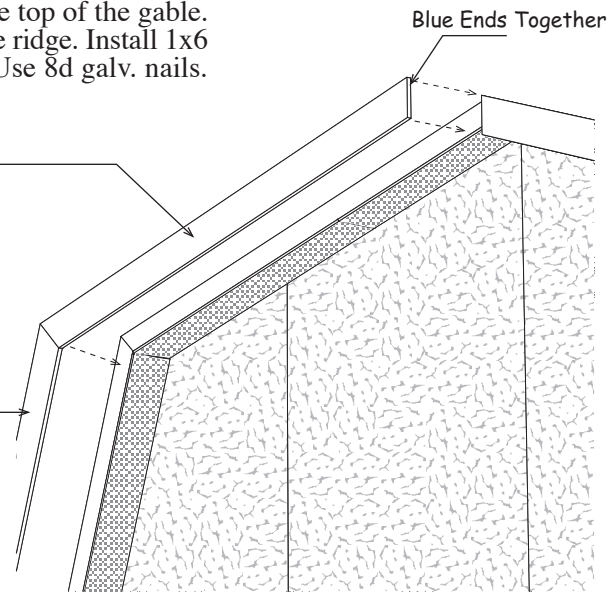

Step 27 Install Door Trim

1. Install 3-7/8" x 84" primed LP door jamb material to the sides of the door opening. Install door jamb flush with the siding. Use 8d galv. nails.
2. Install (2) two 49" long 1x4 trim boards with angle cuts and a 1x6 keystone (packed in door box) across the top of the door opening. Install the trim boards centered across the opening and 3/4" above the siding. The exposed siding will serve as a door stop when the doors are closed. Use 8d galv. nails spaced 12" apart.

1x6 Keystone

49" Door Trim

3. Install (2) two 1x4-84-3/4" long trim boards flush to the sides of the door opening. Tack these boards with a couple nails, you may want to reposition the trim when you install the doors. The space around the doors will not be even. If your door opening is out of square. You can remove and reposition the side trim to make allowances for this. You can move the trim to make the door spacing equal. Use 8d galv. nails.

Siding Extends
3/4" Below Trim

84" LP
Door Jamb

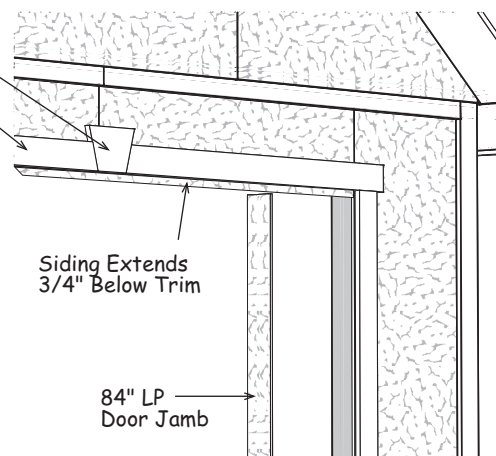

Install Roofing — Not Supplied in Kit

1. Install metal roof 'drip' edging along the perimeter of the roof.
2. If you need detailed instructions on installing shingles, there are good publications available online.

Roof Covering (not included)

29	bdl.	Roof Shingles
14	pcs.	Roof 'drip' Edge-10'
930	sq. ft.	Felt Paper

Step 28 Install Door Stop on Left Door

Qty.	Material Shipped in 48" Door Kit	
2	ea.	48" x 84" Pre-built Doors
2	ea.	12" x 42" Transom Windows
2	ea.	1x4" x 84" Door Trim
2	ea.	1x4" x 48-3/4" Door Trim
1	ea.	1x6" x 10" Keystone
2	ea.	3-7/8" x 84" LP 3/8" Primed Door Jamb
6	ea.	6" Door Hinges
1	ea.	Door Handle & Latch
1	ea.	6" Barrel Bolt
52	ea.	2" Hinge Screws
16	ea.	3/4" Pan Head Screws
10	ea.	1-1/2" Exterior Screws
32	ea.	White Window Screws

Install a 4-1/4" x 83" long board as a door stop to the right side of one of the doors. This will be the left door when installed. The door stop should extend 3/4" beyond the frame of the door. Install with 1-1-2" exterior screws packed in the main component kit. Space screws 12" apart.

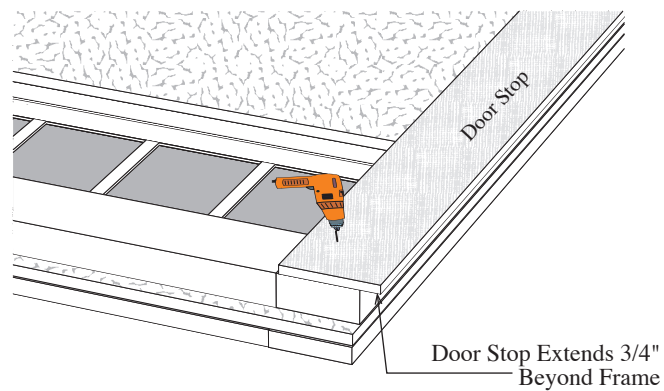

Step 29 Install Doors



If your door opening is out of square, the space around the doors will not be even. You can remove and re-position the side trim to make allowances for this. The side trim does not have to be flush with the frame of the door opening. You can move the trim in or out to make the door spacing equal.

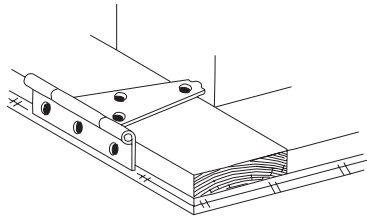

1. Install (3) three 6" hinges to sides of the doors. To position the hinge properly, hold the rectangular plate against the frame. Use 2" black screws.
2. Before fastening the hinges to the trim, temporarily prop the doors in the opening. Leave a space at the top and between the doors and the side trim to allow room for the doors to expand due to humidity.
3. Determine position of hinges and install to side trim with 2" screws.
4. Install the window using the short white screws.
5. Install door handle using 2" black screws into the pre-drilled hole on right side door. When the handle is turned the inside latch will hold doors closed. Tighten set screw to finish.

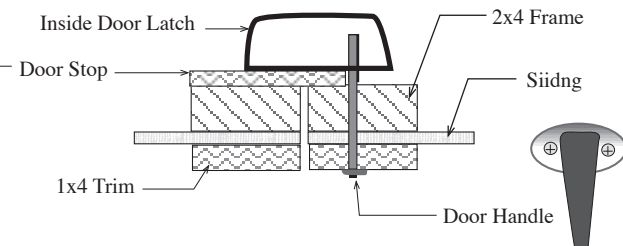
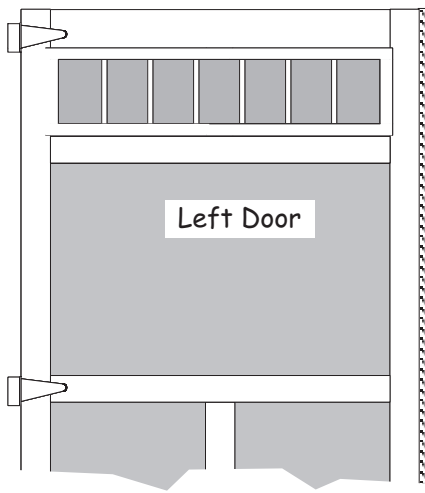

6. Install a barrel bolt using 3/4" pan head screws on the lower back of the door to secure this door in place when closed. You will need to drill a hole for the round shaft to drop into.
7. Install another barrel bolt at the top of the door.

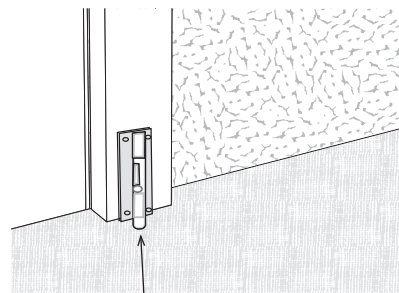



Barrel Bolt on the back of left door

Packing List Virginia 16' Wide x 32' Building Kit

Qty.	<i>Material in 4' Extension Kit</i>		
4 ea.	2x6	x 81-3/4"	Truss Top Cord
4 ea.	2x6	x 71-3/8"	Truss Leg
4 ea.	2x4	x 10"	Soffit Blocks
4 ea.	10-1/2"	x 31-3/4"	Truss Gusset
8 ea.	11-3/4"	x 30"	Truss Gusset
2 ea.	5-1/4"	x 48"	Primed Soffit Panels
4 ea.	2x6		Metal Hangers
6 ea.	2x10		Metal Hangers
1 lb	6d common and 10d sinker nails		

Qty.	<i>Material Shipped by Local Supplier</i>		
100	2x4	-	Pre-cut Wall Studs
6	2x4	8'	Wall Plates (treated)
4	2x4	12'	Wall plates (treated)
1	2x4	16'	Wall plates (treated)
6	2x4	8'	Framing Lumber
4	2x4	10'	Framing Lumber
8	2x4	12'	Framing Lumber
3	2x4	16'	Framing Lumber
8	1x4	8'	Trim Boards
4	1x4	10'	Trim Boards
2	2x6	12'	Tie Plates
2	2x8	10'	Door Header
3	2x10	8'	Floor Joist & Headers
8	2x10	12'	Floor Joist & Headers
17	2x10	16'	Floor Joist
16	4x8	3/4"	T&G Loft Flooring
26	4x8	3/8"	LP Primed Siding
24	4x8	7/16"	OSB Sheathing

Packing List West Virginia 16' Wide x 32' Building Kit

Qty.	Material Shipped on 'A' Pallet		
2	Pre-built Gable Frames	21-3/4" x	48"
2	Pre-built Gable Frames	19-1/4" x	48"
26	Truss - Legs	2x6 x	71-3/8"
6	Truss Plates	2x6 x	84"
4	Gable Overhang	2x4 x	82-5/8"
4	Gable Wall Studs	2x4 x	80-1/2"
4	Gable Wall Studs	2x4 x	72-5/8"
1	Gable Wall Studs	2x4 x	64-1/2"
6	Gable Wall Framing	2x4 x	47-3/4"
2	Front Gable Overhang Trim	1x4 x	8"
18	Soffit Blocks	2x4 x	10"
4	Soffit Blocks w/Siding	2x6 x	10"
3	7/16" OSB Sheathing	48" x	83"
2	7/16" OSB Sheathing	48" x	72"
4	7/16" OSB Sheathing	48" x	59"
1	OSB Header Filler	23-3/4" x	48"
4	Truss Gussets	11-3/4" x	30"
8	LP 3/8" Siding Fillers	1-1/2" x	48-3/4"
18	1/2" OSB Gable Fillers	(see detail below)	
1/2" OSB Gable Fillers			
2	Ridge	4	Knee
			
12 Straight			
			

Qty.	Material Shipped on 'B' Pallet		
26	Truss - Top Cord	2x6 x	81-3/4"
4	Gable Overhang	2x4 x	81-3/4"
3	Gable Wall Studs	2x4 x	64-1/2"
4	Gable Trim	1x6 x	84"
4	Gable Trim	1x6 x	82-1/4"
4	LP Siding Panels	80-1/2" x	48-3/4"
2	LP Siding Panels	14-1/2" x	48-3/4"
14	LP Primed Soffit Panels	5-1/4" x	48-3/4"
8	LP Primed Soffit Panels	8" x	48-3/4"
1	7/16" OSB Sheathing	48" x	83"
2	7/16" OSB Sheathing	48" x	72"
18	Truss Gussets	10-1/2" x	31-3/4"
32	Truss Gussets	11-3/4" x	30"

Qty.	Hardware Breakdown 'A' Pallet		
5	lbs.	16d	Galvanized Spiral Nails
10	lbs.	10d	Coated Sinkers
15	lbs.	8d	Galvanized Nails
7	lbs.	8d	Galvanized Spiral Nails
15	lbs.	6d	Common Nails
7	lb.	1-1/2"	Hanger Nails
150	1-5/8"	Stainless Soffit Screws	
75	2-1/2"	Wood Screws	
100	3"	Wood Screws	
18	2x6	Joist Hangers	
28	2x10	Joist Hangers	
40	7/16"	Plyclips for roof sheathing	